

91W10
Advanced Individual
Training Course



Evacuation Handbook

Department of the Army
Academy of Health Sciences
Fort Sam Houston, Texas 78234

<u>Introduction to the Medical Evacuation System</u>	1-3
• Medical Evacuation System	
• Echelons of Care	
<u>Effects of Geneva Convention on MEDEVAC</u>	4-6
• Identify Distinctive Markings and Camouflage of Medical Facilities and Evacuation Platforms	
• Identify Medical Aircraft	
• Understanding Self-Defense and Defense of Patients	
• Treating and Guarding of Enemy Prisoners of War	
• Compliance with Geneva Conventions	
<u>Evacuation Request Procedures</u>	7-16
• Determination to Request Medical Evacuation and Assignment of Medical Evacuation Precedence	
• Unit Responsibilities in Evacuation	
• Collect Medical Evacuation Information	
• Prepare a Medical Evacuation Request	
• Identify Types of Medical Evacuation Request Formats and Procedures	
• Relay Requests	
<u>Perform Casualty Triage</u>	17-21
• Identify the Principles Which Govern the Priorities for Treatment and Evacuation	
• Perform Triage-Sorting Multiple Casualties into Priorities for Treatment and Evacuation	
• Prioritize Casualties for Medevac by Categories	
• Prepare a Medical Evacuation (MEDEVAC) Request	
<u>U.S. Field Medical Card (FMC)</u>	22-24
• Use, Components, and Requirements of the Field Medical Card (FMC)	
• Provide Minimum Information Required on the FMC Review Authorized Abbreviations	
• Steps in Initiating the Field Medical Card	
<u>Manual Evacuation</u>	25-34
• Steps in Casualty Handling	
• General Rules for Bearers	
• Manual Carries	
• Position the Casualty	
• Categories of Manual Carries	
• Special Manual Evacuation Techniques	
<u>Litter Evacuation</u>	35-42
• Standard Litters	
• Dress a Litter	
• Use Patient Securing Straps	
• Identify General Rules for Litter Bearers	
• Use Spine Boards and the Kendrick Extraction Device (KED)	

Evacuation Platforms.....43-56

- Review Army Ground Ambulances and Assigned Medical Personnel
- Review of Medical Air Ambulances
- Non medical Vehicles Used for Casualty Evacuation or Medical Evacuation
- United States Army and Air Force Medical and No medical Aircraft

Appendix A – Evacuation Request Procedures, Competency Skill Sheets

Appendix B – Perform Casualty Triage, Competency Skill Sheets

Appendix C – Manual Evacuation, Competency Skill Sheets

Appendix D – Litter Evacuation, Competency Skill Sheets

Appendix E – Evacuation Platforms, Competency Skill Sheets

TERMINAL LEARNING OBJECTIVE

Given a standard fully stocked M5 Bag or Combat Medic Vest System. You encounter casualty(ies) that has/have been assessed and injury(ies) prioritized. A field medical card (FMC) has been initiated and attached to the casualties' uniform. Unable to maintain casualty(ies) in the area. Casualty(ies) requires/require evacuation to the next echelon of care.

Medical Evacuation System

The purpose of the Medical Evacuation System is to ensure that the sick and injured are moved quickly into and through the Combat Health Support system

The preponderance of soldiers who die in combat do so within minutes due to penetrating trauma and hemorrhage

In order to save lives prompt localization, resuscitation and stabilization, followed by timely/rapid evacuation of casualties is essential

Soldiers on the dispersed and non-linear battlefield are subject to increased evacuation legs

Medical evacuation encompasses

- (1) Collecting the wounded
- (2) Casualty assessment
- (3) Casualty stabilization
- (4) Sorting (Triage) and prioritizing
- (5) Reporting location and casualty status
- (6) Anticipating complications and being ready to perform emergency medical intervention

The benefits of an efficient medical evacuation system are

- (1) Minimizes mortality by rapidly and efficiently moving the sick , injured, and wounded to a MTF
- (2) Quickly clears the battlefield enabling the tactical commander to continue his mission
- (3) Builds the morale of the soldiers by demonstrating that care is quickly available if they are wounded
- (4) Provides en route medical care that is essential for improving the prognosis and reducing disability of wounded, injured, or ill soldiers

Additional benefits of an efficient medical evacuation system are

- (1) Provide timely re supply of medical supplies through the backhaul method using returning ambulances
- (2) Acts as a carrier of medical records and re supply requests
- (3) Provides transportation of medical personnel and equipment

Medical evacuation is performed by dedicated medical vehicles and aircraft that are staffed with medical personnel who provide en-route medical care.

- (1) Medical evacuation is conducted using vehicles specifically designed to provide en-route medical care
- (2) The provision of en route care on medically equipped vehicles or aircraft enhances casualty survivability

Casualty Evacuation (CASEVAC) is a term used by non medical units to refer to the movement of casualties aboard non medical vehicles or aircraft.

- (1) En-route care is limited to the equipment carried by the individual providing care
 - (a) Combat Lifesavers
 - (b) Buddy aid
- (2) The decision to use this form of casualty transport is a decision made by the commander based on
 - (a) Availability of organic medical platoon evacuation assets
 - (b) The number of casualties
 - (c) The tactical situation
- (3) Medical regulating is the tool used to identify patient's awaiting evacuation to the next echelon of medical care, it:
 - (a) Coordinates and controls the movement of patients through the echelons of care
 - (b) Includes the functions of casualty reporting and accountability

Echelons of medical care

Combat health support is arranged in echelons of care. Each echelon reflects an increase in medical capabilities while retaining the capabilities found in the preceding echelon

Capabilities of each echelon consist of

- (1) Echelon I. The first medical care that a soldier receives is provided at Echelon I. This echelon of care includes:
 - (a) Immediate far forward care
 - (b) Disease in non battle injury prevention(DNBI)
 - (c) Combat stress control preventive measures
 - (d) Patient collection
 - (e) Medical evacuation from supported units to supporting Medical Treatment Facilities (MTFs)
 - (f) Treatment provided by designated combat medics or treatment squads (Battalion Aid Stations [BASs]) in conventional forces
- (2) Echelon II. At this echelon, care is provided at the clearing stations that are operated by the treatment platoons of the medical company. This echelon of care includes.
 - (a) Emergency medical treatment including beginning resuscitation is continued

- (b) Additional emergency measures are instituted but do not go beyond the measures dictated by immediate necessities
 - (c) O+ Whole blood is available here
 - (d) Limited X-ray, laboratory, and dental capabilities are present here
- (3) Echelon III. At this echelon the casualty is treated in an MTF staffed and equipped to provide resuscitation, initial wound surgery, and post operative treatment.
- (4) Echelon IV. At Echelon IV, the patient is treated in a hospital staffed and equipped for general and specialized medical and surgical care to stabilize the patient for further evacuation out of theatre.
- (4) Echelon V. Echelon V care is provided by support base hospitals generally located outside the theatre of operations.

It is the medical evacuation system that moves casualties/patients into and through each echelon of medical care provided

TERMINAL LEARNING OBJECTIVE

You encounter casualty(ies) that has/have been assessed and injury(ies) prioritized. A field medical card (FMC) has been initiated and attached to the casualties' uniform. The rights and duties set forth in the Conventions are part of the supreme law of the land. The United States is obligated to adhere to these obligations even when an opponent does not. It is a DOD and Army policy to conduct operations in a manner consistent with these obligations.

Identify Distinctive Markings and Camouflage of Medical Facilities and Evacuation Platforms

All US medical facilities and units, except veterinary, display the distinctive flag of the Geneva Conventions. The flag consists of a red cross on a white background. It is displayed over the unit or facility and in other places as necessary to adequately identify the unit or facility as a medical facility

The Geneva Conventions authorizes the use of the following distinctive emblems on a white background:

- (1) Red Cross
- (2) Red Crescent
- (3) Red Lion
- (4) Sun

In operations conducted in countries using an emblem other than the Red Cross on a white background, US soldiers must be made aware of the different official emblems

United States forces are legally entitled to only display the Red Cross

- (1) However, commanders have authorized the display of both the Red Cross and the Red Crescent to accommodate Host Nation concerns and to ensure that confusion of emblems would not occur
- (2) Such use of the Red Crescent must be in a smaller size than the Red Cross

Camouflage of medical facilities (medical units, medical vehicles, and medical aircraft on the ground) are authorized when the lack of camouflage might compromise tactical operations

- (1) The marking of facilities may be ordered by a NATO commander of at least brigade level or equivalent
- (2) Such an order is to be temporary and local in nature and is rescinded as soon as circumstances permit
- (3) It is not envisioned that fixed, large medical facilities will be camouflaged

Identify Medical Aircraft

Medical aircraft used exclusively for the removal of the sick and wounded and for the transport of medical personnel and equipment shall not be attacked, but shall be respected by belligerents, while flying at heights, times, and on routes specifically agreed upon between belligerents concerned

Medical aircraft shall bear, clearly marked, the distinctive emblem together with their national colors on their lower, upper, and lateral surfaces

Unless agreed otherwise, flights over enemy or enemy-occupied territory are prohibited

Medical aircraft shall obey every summons to land. In the event that a landing is thus imposed, the aircraft with its occupants may continue its flight after examination, if any

In the event of involuntary landing in enemy or enemy-occupied territory, the wounded and sick, as well as the crew of the aircraft, shall be prisoners of war; medical personnel will be treated as designated in the Geneva Conventions

Understanding Self-Defense and Defense of Patients

When engaging in medical evacuation operations, medical personnel are entitled to defend themselves and their patients. They are only permitted to use small arms.

The mounting of offensive weapons on dedicated medical evacuation vehicles and aircraft jeopardizes the protections afforded by the Geneva Conventions.

These offensive weapons can include, but are not limited to:

- (1) Machine guns
- (2) Grenade launchers
- (3) Hand grenades
- (4) Light antitank weapons

Medical personnel are only permitted to fire in their personal defense and for the protection of the wounded and sick in their charge against marauders and other persons violating the law of war

Treating and Guarding Enemy Prisoners of War

Care and treatment of Enemy Prisoners of War

- (1) The standard of care for EPW's is the same as for U.S. forces IAW the Geneva Convention
- (2) The standard of evacuation for EPW's is the same as for U.S. forces IAW the Geneva Convention

- (3) Sick, injured, or wounded EPWs are treated and evacuated through normal medical channels, but are physically segregated from US, allied, or coalition patients
- (4) Practice the five S's when dealing with wounded EPW's
 - (a) Search, for weapons and documents. Report findings
 - (b) Segregate into groups of Enlisted, noncommissioned Officers, and Officers
 - (c) Silence, keep em quiet
 - (d) Safeguard, protect them
 - (e) Speed to the rear, The EPW patient is evacuated from the Combat Zone as soon as his medical condition permits
 - (f) Inform Higher headquarters of the situation

Personnel resources to guard EPW patients are provided by the echelon commander. Medical personnel do not guard EPW patients

Compliance with the Geneva Conventions

The US is a party to and signatory of the Geneva Conventions. These Conventions afford protection for medical personnel, facilities, and evacuation platforms (to include aircraft on the ground)

Violation of these Conventions can result in the loss of protection afforded by them

Medical personnel (Medical Platoon Leader's, Platoon Sergeant's, Senior Line Medic's) should inform the tactical commander of the consequences of violating the provisions of these conventions.

The consequences can include the following:

- (1) Medical evacuation assets subjected to attack and destruction by the enemy
- (2) Combat health support capability degraded
- (3) Captured medical personnel becoming prisoners of war rather than retained persons. They may not be permitted to treat fellow prisoners
- (4) Loss of protected status for medical unit, personnel, or evacuation platforms (to include aircraft on the ground)

Even the perception of impropriety can be detrimental to the mission and US interests. Combat Health Support commanders must ensure that they do not give the impression of impropriety in the conduct of medical evacuation operations

TERMINAL LEARNING OBJECTIVE

Given a casualty requiring medical evacuation, and a patient pickup site, request medical evacuation. Necessary equipment and materials: secure operational communications equipment, request format, a standard scale military map, a grid coordinate scale, and training SOL.

Determination to Request Medical Evacuation and Assignment of Medical Evacuation Precedence

The determination to request medical evacuation and assignment of a precedence is made by the senior military person present.

This decision is based on the advice of the senior medical person at the scene, the patient's condition and the tactical situation.

Assignment of a medical evacuation precedence is necessary.

The precedence assigned to the casualty(ies) provides the supporting medical unit and controlling headquarters with:

- (1) Information that is used in determining priorities for committing their evacuation assets
- (2) Validated information in controlling the flow so that resources will not be strained

Overclassification (The tendency to classify a wound as more severe than it actually is) remains a continuing problem

- (1) When properly classified, patients will be picked up as soon as possible
- (2) Pick up is consistent with available resources and pending missions
- (3) Those casualties in greatest need are evacuated first and receive the necessary care required to help ensure their survival

Precedence and the criteria used in resource assignment:

- (1) Priority I – Urgent
 - (a) Assigned to emergency cases that should be evacuated as soon as possible
 - (b) Casualty requires evacuation within a maximum of 2 hours
 - (c) Evacuation required in order to save life, limb, or eyesight
 - (d) Used to prevent complications of serious illness, or to avoid permanent disability
- (2) Priority IA – Urgent-Surgical
 - (a) Assigned to patients who must receive far forward surgical intervention
 - (b) Goal is to save life and to stabilize casualty for further evacuation
- (3) Priority II – Priority
 - (a) Assigned to sick and wounded personnel requiring prompt medical care
 - (b) Used when the individual should be evacuated within 4 hours

- (c) Medical condition could deteriorate to such a degree that he/she will become an URGENT precedence
- (d) Requirements for special treatment are not available locally
- (e) Casualty will suffer unnecessary pain or disability
- (4) Priority III – Routine
 - (a) Assigned to sick and wounded personnel requiring evacuation but whose condition is not expected to deteriorate significantly
 - (b) Sick and wounded in this category should be evacuated within 24 hours
- (5) Priority IV – Convenience: assigned to patients for whom evacuation by medical vehicle is a matter of medical convenience rather than necessity

Unit Responsibilities in Evacuation

Unit requesting evacuation prepares for and assist's during evacuation by:

- (1) Ensuring that the tactical situation permits safe and successful evacuation
- (2) Having an English-speaking representative at the pickup site when evacuation is requested for non-US personnel
- (3) Ensuring that the casualty(ies) are ready for pickup when the request is submitted and provide casualty information, as required
- (4) Receiving backhauled medical supplies and report the type, quantity, and where they are delivered
- (5) Moving patients to the safest aircraft approach and departure point or AXP if they are to be evacuated by air
- (6) Ground personnel should be familiar with principles of helicopter operations

Units must:

- (1) Select and prepare the landing site. It is imperative that the type and number of aircraft are known so that the landing site can be adequately cleared and marked
 - (a) Criteria for Landing Sites:
 - (i) The Landing Zone (LZ) must be free of obstructions with sufficient space for the helicopter to be able to hover and maneuver during landing and takeoff into the prevailing wind whenever possible
 - (ii) Definite measurements for LZs cannot be prescribed since they vary with:
 - * Temperature
 - * Altitude
 - * Wind
 - * Terrain
 - * Loading conditions
 - * Individual helicopter characteristics
 - (iii) 30 Meters in diameter is the minimum requirement
 - (iv) Marking the LZ

- * Any object likely to be blown about by wind from the rotor wash should be removed
- * Obstacles which cannot be removed must be clearly marked so as to be readily seen by the pilot
- (v) Identifying the landing site
 - * When the tactical situation permits the LZ should be marked with the letter H or an inverted Y
 - * Panels used to mark the LZ should be securely anchored to the ground to prevent them from being blown about
 - * The wind should be indicated (tactical situation permitting) with a wind sock or rag tied to a stick in the vicinity of the LZ
 - * Smoke grenades that emit colored smoke as soon as the aircraft is sighted can be used. The color of the smoke is verified by the aircrew and confirmed by the ground personnel
- (2) Personnel loading the injured will take all of their commands regarding approach, loading and unloading of the aircraft from the pilot and crew chief
- (3) Brief the pilot on the position of enemy troops and directs him to other units in the area, if asked
- (4) A qualified soldier guides the helicopter in the landing site using hand signals during landing and takeoff when the tactical situation permits
- (5) Mark friendly positions when armed helicopter escort is provided to prevent fratricide

CAUTION: Failure to follow proper safety procedures can result in injury or death.

Collect Medical Evacuation Information

Location of pickup site (Line 1)

- (1) It is not necessary to encrypt grid coordinates when using secure communications equipment or channel skipping equipment
- (2) To preclude misunderstanding, state that grid zone letters are included in the message.
- (3) Obtain grid coordinates of the pickup site from the grid map of the operational area

NOTE: This information is required so that the evacuation vehicle crew knows where to pick up the casualty and the unit personnel coordinating the evacuation mission can plan the route for the evacuation vehicle (if casualties must be picked up from more than one location)

Radio frequency, call sign, and suffix (Line 2)

- (1) Send the frequency of the radio at the pickup site, not a relay frequency
- (2) The call signs (and suffix if used) on the person to be contacted at the pickup site may be transmitted in the clear
- (3) Obtain radio frequency, call sign, and suffix of signal operation instructions from Signal Operating Instruction (SOI), or the Automated Net Control Device (ANCD) or radio supervisor

NOTE: This information is required so that the evacuation vehicle crew can contact the requesting unit while en-route to obtain additional information (for example, a change in situation, directions, or other information)

Number of Patients by Precedence (Line 3) Report only applicable information and use the appropriate amount(s) and brevity code(s) as follows:

NOTE: The brevity code precedes the description (A- Urgent) in the line number block under the information column of the Procedure for Information Collection and MEDEVAC Request Preparation.

- (1) **A – URGENT Complete** (evacuate as soon as possible or within 2 hours)
- (2) **B - URGENT SURGICAL** (evacuate within 2 hours to the nearest surgical unit)
- (3) **C - PRIORITY** (evacuate promptly or within 4 hours)
- (4) **D - ROUTINE** (evacuate within 24 hours)
- (5) **E - CONVENIENCE** (medical convenience rather than necessity)

NOTE: If two or more categories must be reported in the same request, insert the proword "Break" (e.g., I now separate the text from other parts of the message) between each category. These details are obtained as part of the evaluation(s) of the patient(s), and provided by the medic or the senior person present. This information is required by the unit controlling the evacuation vehicles in order to assist in prioritizing missions when more than one is received.

Special Equipment Required (Line 4). Some of the types of equipment and their brevity codes are as follows:

- (1) **A - None**
- (2) **B - Hoist**
- (3) **C - Extraction equipment**
- (4) **D - Ventilator**

NOTE: Information on special equipment requirements are determined as part of the evaluation(s) of the patient(s), from the medic or the senior person present. This information is required so that the equipment can be placed on board the evacuation vehicle prior to the start of the mission.

Number of Patients by Type (Line 5) Report only applicable information. If requesting MEDEVAC for both types, insert the word "Break" between the litter entry and ambulatory entry.

- (1) L - (Litter) plus the number of patients
- (2) A - (Ambulatory [sitting]) plus the number of patients

NOTE: Obtain information on patients by type, a part of the evaluation(s) of the patient(s), and the number of patients from the medic or the senior person present. This information is required to determine the appropriate number of evacuation vehicles to be dispatched to the pickup site. The information is also needed to configure the vehicles to carry the patients requiring evacuation.

Security of Pickup Site (Wartime) (Line 6) This information is used during wartime. Use one of the following brevity codes to transmit the information concerning pickup-site security.

- (1) N - No enemy troops in the area
- (2) P - Possibly enemy troops in the area (approach with caution)
- (3) E - Enemy troops in the area (approach with caution)
- (4) X - Enemy troops in the area (armed escort required)

NOTE: This information is required to assist the evacuation crew in assessing the situation and determining if assistance is required in accomplishing the mission. More definitive guidance can be furnished to the evacuation vehicle while it is en- route (for example, the specific location of the enemy would assist the crew in planning the approach).

Method of Marking Pickup Site (Line 7), use the following appropriate brevity code(s) for the method of marking the pickup site.

- (1) A - Panels
- (2) B - Pyrotechnic signal
- (3) C - Smoke signal
- (4) D - None
- (5) E - Other

NOTE: This information based on the situation and the availability of materials and is provided by the medic or senior person present. The information is required to assist the evacuation aircraft crew in identifying the specific location of the pickup site. The color of the panels, smoke, or other markings should not be transmitted until the evacuation vehicle contacts the unit just prior to arrival. For security reasons, the crew should identify the color of the marking(s) and the unit should verify the color.

Patient Nationality and Status (Line 8). The codes and categories are as follows:

- (1) A - U.S. military
- (2) B - U.S. civilian
- (3) C - Non-U.S. military
- (4) D - Non-U.S. civilian
- (5) E - Enemy Prisoner of War (EPW)

NOTE: The number of patients in each category need not be transmitted. Obtain this information as part of the patient evaluation(s), from the medic or senior person present. This information is required in planning for destination of facilities and the need for guards. The unit requesting evacuation support should ensure that there is an English-speaking representative at the pickup site.

NBC Contamination (Wartime) (Line 9). Use the appropriate brevity code(s) to indicate contamination:

- (1) **N** - Nuclear
- (2) **B** - Biological
- (3) **C** - Chemical

NOTE: Obtain NBC contamination situation information from the medic or senior person present. Include this line only when applicable. This information is required to assist in planning for the mission. Determine which evacuation vehicle will accomplish the mission and when it will be accomplished (arrive at the pickup site). Information concerning the vehicle to be used and the time of arrival can be obtained from the evacuation unit.

Prepare a Medical Evacuation Request

During wartime, brevity codes must be used in preparing all medical evacuation requests

NOTE: Under all wartime conditions, these requests are transmitted by secure means only. Therefore, the use of nonsecure communications dictates that the request be transmitted in encrypted form.

- (1) Use brevity codes listed in FM 8-10-6, Evacuation Request Procedures
- (2) Brevity codes should also be in SOI (ANCD)
- (3) Locally brevity devised codes are not authorized
- (4) The unit preparing the request does not have access to secure communications the medical evacuation request must be encrypted
- (5) Information on the form must be encrypted except:
 - (a) Medical evacuation line number identifier. This information is always transmitted in clear text.
 - (b) Call sign and suffix (Line 2) which can be transmitted in clear text

During peacetime, two line number items (Lines 6 and 9) will change. More detailed procedures for use of the peacetime request format must be developed by each local command to meet specific requirements

General rules of radio communications:

- (1) Transmission Security: The following basic rules are essential to transmission security and will be strictly enforced on all military radiotelephone circuits

- (2) No transmission will be made if it is not authorized by the proper authority
- (3) The following practices are specifically forbidden:
 - (a) Violation of radio silence
 - (b) Unofficial conversation between operators
 - (c) Transmission on a directed net without permission
 - (d) Excessive tuning and testing
 - (e) Transmission of the operator's personal sign or name
 - (f) Unauthorized use of plain language
 - (g) Use of other than authorized PROWORDS
 - (h) Unauthorized use of plain language in place of applicable PROWORDS or operating signals
 - (i) Association of classified call signs and address groups with unclassified call signs
 - (j) Profane, indecent, or obscene language

Call Signs are used in radio communications to identify a communications facility, a command, an authority, or a unit. There are two forms of call signs: complete call signs and abbreviated call signs

Complete call signs consist of a letter - number - letter combination and a suffix and are used when:

- (1) Entering a net in which you do not normally operate
- (2) When so requested by the NCS or another station in the net
- (3) Abbreviated call signs are used at all other times
 - (a) EXAMPLES:
Complete Call Sign _____ A2D28
Abbreviated Call Sign _____ D28
 - (b) If no confusion exists as to which operators are on the radio net, no call signs need be used

Pronunciation of Letters and Numerals

- (1) To avoid confusion and errors during voice transmission, special techniques have been developed for pronouncing letters and numerals
- (2) These special techniques resulted in the phonetic alphabet and phonetic numerals. The phonetic alphabet is used by the operator to spell difficult words and thereby prevent misunderstanding on the part of the receiving operator.
- (3) The phonetic alphabet is also used for the transmission of encrypted messages. For example, the cipher group CMVVX is spoken "CHARLIE MIKE VICTOR VICTOR XRAY."
- (4) Numbers are spoken digit by digit, except that exact multiples of thousands may be spoken as such. For example, 84 is "AIT FOW ER," 2,500 is "TOO FIFE ZE RO ZE RO," and 16,000 is "WUN SIX TOUSAND."
- (5) The date-time group is always spoken digit by digit, followed by the time zone indication. For example, 291205Z is "TOO NIN-ER WUN TOO ZE-RO FIFE ZOO-LOO."

- (6) Map coordinates and call sign suffixes also are spoken digit by digit. To keep voice transmission as short and clear as possible, radio operators use procedure words (PROWORDS) to take the place of long sentences.

Identify Types of Medical Evacuation Request Formats and Procedures

The medical evacuation request is used for requesting evacuation support from

- (1) Air ambulances
- (2) Ground ambulances

Two established medical evacuation request formats (ref. 9 line MEDEVAC request)

- (1) Wartime
- (2) Peacetime

Differences between wartime and peacetime medical evacuation request formats and procedures

- (1) Line 6 of request
 - (a) Change from number and type of wound, injury, or illness (two gunshot wounds and one compound fracture) in peacetime to Security of pickup site in wartime
 - (b) If serious bleeding is reported, the patient's blood type should be given, if known
- (2) Line 9 of request
 - (a) Change from description of terrain (flat, open, sloping, wooded) in peacetime to NBC contamination in wartime
 - (b) If possible, include relationship of landing area to prominent terrain features

Differences in security between wartime and peacetime in requesting procedures

- (1) Under all nonwar conditions, the safety of US military and civilian personnel outweighs the need for security: Clear text (Information not encrypted for transmission) transmissions of medical evacuation requests are authorized
- (2) During wartime, the rapid evacuation of patients must be weighed against the importance of unit survivability: Wartime medical evacuation requests are transmitted by secure means only

Transmit the Request

The medical evacuation request should be made by the most direct communications means to the medical unit that controls evacuation assets.

The communications means and channels used depend on the situation (organization, communication means available, location on the battlefield, and distance between units).

The primary and alternate channels to be used are specified in the unit

evacuation plan.

Security transmissions

- (1) Under all wartime conditions, these requests are transmitted by SECURE MEANS only
- (2) Nonsecure communications dictates that the request be transmitted in ENCRYPTED FORM
- (3) Regardless of the type (secure or nonsecure) of communications equipment used in transmission must:
 - (a) Make proper contact with the intended receiver
 - (b) Use the effective call sign and frequency assignments from the SOI
 - (c) Use the proper radio procedure
 - (d) Ensure that transmission time is kept to a minimum (25 Seconds maximum)
 - (e) Provide the opening statement: "I HAVE A MEDEVAC REQUEST"

Receiver Acknowledgement - after the appropriate opening statement is made, the transmitting operator

- (1) Breaks for acknowledgment
- (2) Authentication by the receiving or transmitting unit should be done in accordance with the TSOP

Clear Text and Encrypted Transmissions

- (1) If secure communications equipment is used in transmission
 - (a) Request will be transmitted in CLEAR TEXT
 - (b) However, if the communications equipment used in transmission is not secure, the request must be transmitted in encrypted form with the exception of the following:
 - (i) Medical evacuation line number identifier (Line 1, Line 2)
 - (ii) Call sign and suffix in Line 2 may be transmitted in the clear

Letter and Numeral Pronunciation

- (1) Letters and numbers pronounced according to standard radio procedure
- (2) Give Line Number Identifier followed by applicable information

Medical Evacuation Request Line Numbers 1 through 5

- (1) Line numbers 1 –5 must be transmitted first
- (2) Allows evacuation unit to begin mission without delay
- (3) Lines 6 – 9 should be transmitted as soon as possible

Monitoring requirements

- (1) After transmission and authentication monitor frequency
- (2) Wait for additional information
- (3) Relay contact information from evacuation vehicles

Relay Requests

NOTE: If the unit receiving the request does not control the evacuation means, it must relay the request to the headquarters on unit that has control, or to another relaying unit. When relaying to a unit without secure communications means:

Transmit in encrypted form

Regardless of method of transmission, must ensure relay is the exact information originally received

Transmit by secure means

Radio call sign and frequency relayed (Line 2 of the request) should be that of the requesting unit and not that of the relaying unit

If possible, intermediate headquarters or units relaying requests will monitor the frequency specified in Line 2

TERMINAL LEARNING OBJECTIVE

Given a standard fully stocked M5 Bag or Combat Medic Vest System. You encounter multiple casualties with a variety of symptoms and suspected injuries.

Identify the Principles Which Govern the Priorities for Treatment and Evacuation

Triage - a system used for categorizing and sorting patients according to the severity of their injuries. AFFORD THE GREATEST NUMBER OF CASUALTIES

THE GREATEST CHANCE OF SURVIVAL.

- (1) Survey and classify casualties for the most efficient use of available medical personnel and supplies
- (2) Assures treatment is directed first towards the patients who have the best chance to survive
- (3) Locate troops with minor wounds, and return them to duty

CAUTION: Triage establishes the order of treatment, NOT whether treatment is given, regardless of the injury. Triage is usually the responsibility of the senior medical person.

Determine the tactical and environmental situation

- (1) Necessity to transport casualties to a more secure collection point for treatment
- (2) Number and location of the injured
- (3) Severity of injuries
- (4) Assistance available - buddy-aid, self-aid, medical personnel
- (5) Evacuation support capabilities and requirements (i.e., air ambulance, ground transportation)

Chemical and nuclear weapons exposure

- (1) Not to be used as criteria for sorting
- (2) Field experience with these injuries does not exist

Perform triage - sorting multiple casualties into priorities for emergency care or evacuation to definitive care

Conventional battlefield casualties

- (1) **Immediate** - patient whose condition demands immediate treatment to save life, limb, or eyesight. This category has the highest priority
 - (a) Airway obstruction
 - (b) Respiratory and cardio respiratory distress from otherwise treatable injuries (for example, electrical shock, drowning, or chemical exposure)
 - (i) Cardio respiratory distress may not be considered an immediate condition on the battlefield
 - (ii) It would be classified as expectant - this evaluation is contingent upon the mission, the

- battlefield situation, number of casualties,
support, etc
- (c) Massive external bleeding e.g., amputation
 - (d) Shock
 - (e) Burns of the face, neck, hands, feet, or perineum and genitalia
 - (f) After a casualty with a life/limb-threatening condition has been stabilized, no further treatment (nonlife/limb-threatening) will be given until other "immediate" casualties have been treated
 - (g) Salvage of life takes priority over salvage of limb
- (2) **Delayed** - patients who have less risk of losing life or limb by treatment being delayed
- (a) Open chest wound (without respiratory distress)
 - (b) Abdominal wounds (without shock)
 - (c) Eye injury (severe, without hope of saving eyesight)
 - (d) Other open wounds
 - (e) Fractures
 - (f) Second and third degree burns (not involving the face, hands, feet, genitalia, and perineum) covering 20 percent or more of total body surface area
- (3) **Minimal** - "Walking wounded", can be self-aid or buddy-aid
- (a) Minor lacerations
 - (b) Contusions
 - (c) Sprains and strains
 - (d) Minor combat stress problems
 - (e) Burns 1st or 2d degree under 20 percent of total body surface area and not involving critical areas such as hands, feet, face, genitalia, or perineum
 - (f) Patients in this category usually are NOT evacuated to a medical treatment facility
- (4) **Expectant** - patient so critically injured that only complicated and prolonged treatment offers any hope of improving life expectancy. Category to be used only if resources are limited, if in doubt as to severity of injury, treat in categories above
- (a) Massive head injury with signs of impending death
 - (b) Burns, mostly third degree, covering more than 85 percent of body surface area

Integrated battlefield casualties

- (1) Immediate
 - (a) Presence of life-threatening conventional injuries
 - (b) No signs and symptoms of chemical agent poisoning
- (2) Chemical immediate
 - (a) Presence of signs and symptoms of severe chemical agent poisoning
 - (b) No conventional injuries

- (3) Delayed
 - (a) Presence of mild signs and symptoms of chemical agent poisoning
 - (b) Presence of conventional injuries that are not life-threatening
- (4) Minimal
 - (a) Presence of minor conventional injuries
 - (b) No signs and symptoms of chemical agent poisoning
- (5) Expectant
 - (a) Presence of both severe signs and symptoms of chemical agent poisoning and life-threatening conventional injuries
 - (b) No conventional injuries and not breathing due to chemical agent poisoning

Prioritize casualties for Medevac by categories

Urgent - evacuation required as soon as possible but not later than 2 hours to save life, limb, or eyesight

- (1) Generally, casualties whose condition(s) cannot be controlled and have the greatest opportunity for survival are placed in the urgent category
- (2) Cardio respiratory distress
- (3) Shock not responding to IV therapy
- (4) Prolonged unconsciousness
- (5) Head injuries with signs of increasing ICP
- (6) Burns covering 20% to 85% of total body surface area

Urgent surgical - evacuation is required for patients who must receive far forward surgical intervention to save life and stabilize for further evacuation

- (1) Decreased circulation in the extremities
- (2) Open chest and/or abdominal wounds with decreased blood pressure
- (3) Penetrating wounds
- (4) Uncontrollable bleeding or open fractures with severe bleeding
- (5) Severe facial injuries

Priority - evacuation is required within 4 hours or patient's condition could get worse and become an "urgent" or "urgent surgical" category condition

- (1) Closed-chest injuries, such as rib fractures without a flail segment or other injuries that interfere with respirations
- (2) Brief periods of unconsciousness
- (3) Soft tissue injuries and open or closed fractures
- (4) Abdominal injuries with no decreased blood pressure
- (5) Eye injuries that do not threaten eyesight
- (6) Spinal injuries
- (7) Burns on the hands, face, feet, genitalia or perineum even if under 20% of the total body surface area

Routine - evacuation required within 24 hours for patients requiring additional care, but for whom evacuation is not immediately critical

- (1) Burns covering 20% to 80% of the total body surface area if the casualty is receiving and responding to IV therapy
- (2) Simple fractures
- (3) Open wounds including chest injuries without respiratory distress
- (4) Psychiatric cases
- (5) Terminal cases

Convenience - evacuation of patients by medical vehicle is a matter of convenience rather than necessity

- (1) Minor open wounds
- (2) Sprains and strains
- (3) Minor burns under 20% of total body surface area

Prepare a Medical Evacuation (MEDEVAC) Request

Line 1: Pickup location - provided by unit leader

Line 2: Radio frequency, call sign and suffix - provided by radio/telephone operator (RTO)

Line 3: Number of patients by precedence category

- (1) Determine brevity codes
 - (a) A - urgent
 - (b) B - urgent surgical
 - (c) C - priority
 - (d) D - routine
 - (e) E - convenience
- (2) If using two or more categories, insert the word "break" between codes

Line 4: Special equipment required - (A) none, (B) hoist, (C) extraction equipment, (D) ventilator

Line 5: Number of patients by type - (L) litter + # of Pts, (A) ambulatory + # of Pts

Line 6: Security of pickup site or number/type of wounded, injured, illness

- (1) Security of pickup site (wartime)
 - (a) N - no enemy troops in area
 - (b) P - possible enemy troops in area
 - (c) E - enemy troops in area, approach with caution
 - (d) X - enemy troops in area, armed escort required
- (2) Number and type of wounded, injured, or illness (peace time). Give specific information regarding patient wounds by type (i.e., gunshot, auto accident, heart attack). Report serious bleeding along with patient blood type, if known

Line 7: Method of marking pickup site as provided by unit leader

Line 8: Patients' nationality and status - (A) U.S. military, (B) U.S. civilian, (C) Non-U.S. military, (D) Non-U.S. civilian, (E) EPW (enemy prisoners of war)

Line 9: NBC contamination or terrain description

- (1) NBC contamination, if any (wartime) - (N) nuclear, (B) biological, (C) chemical
- (2) Terrain description (peacetime) includes details of terrain features in and around proposed landing site. If possible, describe relationship of site to prominent terrain feature (i.e., lake, mountain, tower)

As a minimum, the first five items above must be provided in exact sequence listed

TERMINAL LEARNING OBJECTIVE

You encounter casualty(ies) that has/have been assessed and injury(ies) prioritized. A field medical card (FMC) has been initiated and attached to the casualties' uniform. Unable to maintain casualty(ies) in the area. Casualty(ies) requires/require evacuation to the next echelon of care.

Use, Components, and Requirements of the Field Medical Card (FMC)

Use - the field medical card (DD Form 1380) is used to document medical care given to casualties in a theater of operations

Components

- (1) Field medical cards are issued as a pad
- (2) Each pad contains an original card, a carbon protective sheet, and a duplicate
- (3) Each pad has an attached wire to attach to patient

Requirements - the field medical card must be

- (1) Reviewed and signed by the supervising AMEDD officer
- (2) Prepared on any patient treated within a theater of operations
- (3) Attached to the patient's clothing, where it will remain until their arrival at the hospital, their death and burial, or their return to duty
- (4) Written legibly and concisely

Provide minimum information required on the FMC

NOTE: Each block of the FMC provides critical information to subsequent caregivers and must be properly filled in by the attending medic. Complete as a minimum, blocks 1,3,4,7,9, and 11. Complete blocks 2,5,6,8,12,13,14,15,16, and 17 as time permits.

BLOCK 1

- (1) Full name
- (2) Rank/grade
- (3) Social security number (SSN)
- (4) Military occupational specialty (MOS) or area of concentration for specialty code
- (5) Religion and sex

BLOCK 3

- (1) Use the figures in the block to show the location of the injury or injuries
- (2) Check the appropriate box (es) to describe the casualty's injury or injuries

BLOCK 4 - check the appropriate box for level of consciousness

BLOCK 7

- (1) Check the yes or no box
- (2) Write the dose administered
- (3) Write the date and time it was administered

BLOCK 9

- (1) Write treatment given
- (2) Use block 14 for additional space

BLOCK 11 - your initials on the far right of the block

**Complete the other blocks as time permits. Most blocks are self-explanatory.
The following specifics are noted:**

- (1) Block 2 - enter the casualty's unit and country of whose armed forces he/she is a member. Check the armed services of the casualty
- (2) Block 5 - write the casualty's pulse rate and the time that the pulse was measured
- (3) Block 6 - check the yes or no box. If a tourniquet is applied write the time and date it was applied.
- (4) Block 8 - write in the time, date, and type of IV solution given
- (5) Block 10 - check the appropriate box. Write the date and time of disposition
- (6) Block 12 - write the time and date of the casualty's arrival. Record the blood pressure, pulse, and respirations in the space provided.
- (7) Block 13 - document the appropriate comments by the date and time of observation
- (8) Block 14 - document the provider's orders by date and time. Record the dose of tetanus administered and the time it was administered. Record the type and dose of antibiotic administered and the time it was administered
- (9) Block 15 - the signature of the provider or medical officer and date is written in this block
- (10) Block 16 - check the appropriate box and enter the date and time
- (11) Block 17 - this block will be completed by the United Ministry Team. Check the appropriate box of the service provided. The signature of the chaplain providing the service is written in this block.

Review Authorized Abbreviations

NOTE: In block 3 use only authorized abbreviation, however abbreviations may not be used for diagnostic terminology. Abraded wound - Abr. W

Contused wound - Cont. W
Fracture (compound) open - FC
Fracture (compound) open comminuted - FCC
Fracture simple (closed) - FS
Lacerated wound - LW
Multiple wounds - MW
Penetrating wound - Pen W
Perforating wound - Perf W
Severe - SV
Slight - SL
Gun Shot Wound - GSW

Steps in Initiating the Field Medical Card

Remove DD Forms 1380 from medical aid bag

Remove protective sheet from the carbon copy

Complete the minimum required blocks

Keep filled out white sheet (without wire)

Attach top form to casualty's uniform by twisting wire after threading it through the top buttonhole of uniform.

Keep field medical card in plain view.

TERMINAL LEARNING OBJECTIVE

Given a CMVS, immobilization splints and equipment and documentation forms. You encounter a casualty who requires medical treatment. Casualty must be extricated and removed from the immediate area. Initial assessment of casualty is not completed.

Overview of Manual Evacuation

Manual evacuation is the process of transporting casualties by manual carries. It is accomplished without the aid of a litter or other forms of transport. It is intended to end at the point where a more sophisticated means of evacuation becomes available. For example, manual evacuation ends when a litter, vehicle, or other form of conveyance is available.

Steps in Casualty Handling

Casualty Handling:

- (1) Casualties evacuated by manual means must be carefully handled.
- (2) Rough or improper handling may cause further injury to the casualty.
- (3) The evacuation effort should be organized and performed methodically.
- (4) Each movement made in lifting or moving casualties should be performed as deliberately and as gently as possible.
- (5) Casualties should not be moved before the type and extent of their injuries are evaluated and the required first aid (self-aid, buddy aid, or combat lifesaver) or Emergency Medical Treatment (combat medic or ambulance crew) is administered.

NOTE: The exception to this occurs when the situation dictates immediate movement for safety reasons. For example, if a casualty is on the ground near a burning vehicle, it may be necessary to move him a safe distance away from the vehicle. This situation dictates that the urgency of casualty movement outweighs the need to administer first aid or EMT. Even when immediate movement of casualties is required, they should be moved only far enough to be out of danger.

Steps taken prior to moving the casualty:

- (1) Many lifesaving and life-preserving measures are carried out before evacuating injured or wounded soldiers
- (2) Except in extreme emergencies, the type and extent of injuries must be evaluated before any movement of the casualty is attempted
- (3) Measures are taken, as needed, to:
 - (a) Open the airway and restore breathing and heartbeat
 - (b) Stop bleeding prevent or control shock
 - (c) Protect the wound from further contamination
- (4) When a fracture is evident or suspected, the injured part must be immobilized
 - (a) Every precaution must be taken to prevent broken ends of bone from cutting through muscle, blood vessels, nerves, and skin

- (b) When a casualty has a serious wound, the dressing over the wound should be reinforced to provide additional protection during manual evacuation

General Rules for Bearers

General Rules for Bearers:

- (1) In manual evacuation, individuals performing the evacuation are referred to as bearers
- (2) Improper handling of a casualty can result in injury to the bearers as well as to the casualty
- (3) To minimize disabling injuries (muscle strain, sprains, or other injuries) that could hamper the evacuation effort

The following rules should be followed:

- (1) Use the body's natural system of levers when lifting and moving a casualty. Know your physical capabilities and limitations
- (2) Maintain solid footing when lifting and transporting a casualty
- (3) Use the leg muscles (not the back muscles) when lifting or lowering a casualty
- (4) Use the shoulder and leg muscles (not the back muscles) when carrying or standing with a casualty
- (5) Keep the back straight; use arms and shoulders when pulling a casualty
- (6) Work in unison with other bearers, using deliberate, gradual movements. Slide or roll, rather than lift, heavy objects that must be moved
- (7) Rest frequently, or whenever possible, while transporting a casualty

NOTE: Normally, a casualty's individual weapon is not moved through the evacuation chain with him. Weapons are turned in at the first available MTF (BAS or division clearing station) to be returned to the parent unit through supply channels. Individual equipment, to include protective clothing and mask, remains with the casualty and is evacuated with him.

Manual Carries

Manual Carries

- (1) Manual carries are tiring for the bearers and involve the risk of increasing the severity of the casualty's injuries.
- (2) In some instances, however, they are essential to save the casualty's life.
- (3) When a litter is not available or when the terrain or the tactical situation makes other forms of casualty transportation impractical, a manual carry may be the only means to transport a casualty to where a combat medic can treat him.

The distance a casualty can be transported by a manual carry depends upon many factors, such as:

- (1) Strength and endurance of the bearers

- (2) Weight of the casualty
- (3) Nature of the injuries
- (4) Obstacles encountered during transport
- (5) Terrain and weather

Position the Casualty

Casualty Positioning

- (1) The first step in any manual carry is to position the casualty to be lifted.
- (2) If conscious, the casualty should be told how s/he is to be positioned and transported.
- (3) This helps to lessen the casualty's fear of movement and to gain cooperation.
- (4) It may be necessary to roll the casualty onto their abdomen, or back, depending upon the position in which s/he is lying and the particular carry to be used.
 - (a) To roll a casualty onto their abdomen
 - (i) Kneel at the casualty's uninjured side
 - (ii) Place his arms above his head; cross his ankle that is farther from you over the one that is closer to you
 - (iii) Place one of your hands on the shoulder that is farther from you; place your other hand in the area of his hip or thigh
 - (iv) Roll the casualty gently toward you onto their abdomen
 - (b) To roll a casualty onto their back, follow the same procedure described in (a) above, except gently roll the casualty onto his back, rather than onto their abdomen

Categories of Manual Carries

- (1) One-Man Carries. These carries should be used when only one bearer is available to transport the casualty
 - (a) The fireman's carry, is one of the easiest ways for one individual to carry another
 - (b) Fireman's carry 2, The alternate method of the fireman's carry should be used only when the bearer believes it to be safer for the casualty because of the location of his wounds



- (c) The arms carry, is useful in carrying a casualty for a short distance (up to 50 meters) and for placing a casualty on a litter



- (d) Supporting carry, The casualty must be able to walk, or at least hop, on one leg, using the bearer as a crutch. This carry can be used to transport a casualty as far as he is able to walk or hop



- (e) Saddleback carry, Only a conscious casualty can be transported by the saddleback carry because he must be able to hold onto the bearer's neck



- (f) Pack-strap carry, the casualty's weight rests high on your back. This makes it easier for you to carry the casualty a moderate distance (50 to 300 meters). To eliminate the possibility of injury to the casualty's arms, you must hold the casualty's arms in a palms-down position.



NOTE: Once the casualty is positioned on the bearer's back, the bearer remains as erect as possible to prevent straining or injuring his back.

- (g) Pistol-belt carry, is the best one-man carry for a long distance (over 300 meters). The casualty is securely supported upon your shoulders by a belt. Both your hands and the casualty's (if conscious) are free for carrying a weapon or equipment, or for climbing obstacles. With your hands free and the casualty secured in place, you are also able to creep through shrubs and under low- hanging branches



NOTE: If pistol belts are not available for use, other items such as rifle slings, two cravat bandages, two litter straps, or any other suitable material which will not cut or bind the casualty may be used.

- (h) The pistol-belt drag, as well as other drags, is generally used for short distances (up to 50 meters). This drag is useful in combat, since both the bearer and the casualty can remain closer to the ground than in other drags.



- (i) The neck drag, is useful in combat because the bearer can transport the casualty as he creeps behind a low wall or shrubbery, under a vehicle, or through a culvert. If the casualty is unconscious, his head must be protected from the ground. The neck drag cannot be used if the casualty has a broken arm.



NOTE: If the casualty is conscious, he may clasp his hands together around your neck. If the casualty is unconscious, protect his head from the ground.

- (j) The cradle-drop drag is effective in moving a casualty up or down steps.



NOTE: If the casualty needs to be moved up the steps, you should back up the steps, using the same procedure. Cradle-drop drag. The load-bearing equipment (LBE) carry using the bearer's LBE can be used with a conscious casualty.

(2) Two-Man Carries. These carries should be used whenever possible. They provide more comfort for the casualty, are less likely to aggravate injuries, and are less tiring for the bearers. Five different two-man carries can be used.

(a) The Two-man supporting carry can be used in transporting both conscious and unconscious casualties. If the casualty is taller than the bearers, it may be necessary for the bearers to lift the casualty's legs and let them rest on their forearms.

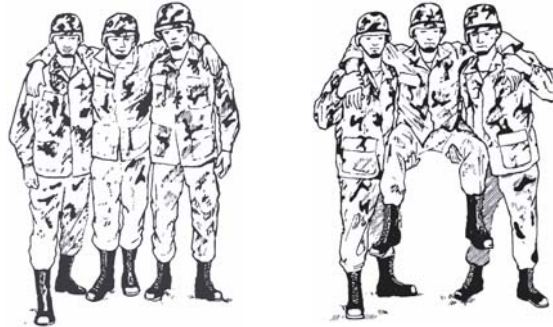

(b) The two-man arm's carry, is useful in carrying a casualty for a moderate distance (50 to 300 meters) and placing him on a litter. To lessen fatigue, the bearers should carry the casualty high and as close to their chests as possible.

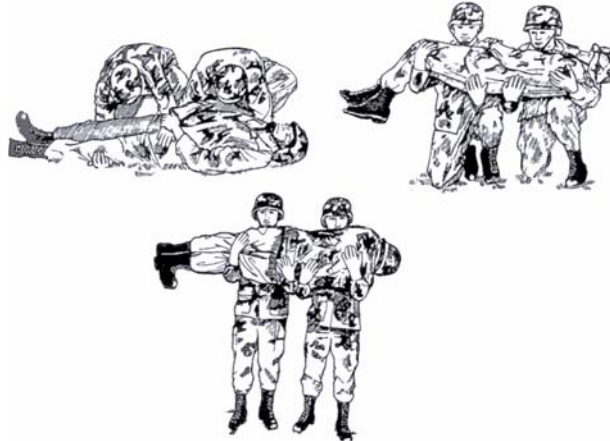

- (c) The two-man fore-and-aft carry, is a useful two-man carry for transporting the casualty over a long distance (over 300 meters).



- (d) Four hand seat carry, only a conscious casualty can be transported with the four-hand seat carry since he must help support himself by placing his arms around the bearers' shoulders. This carry is especially useful in transporting a casualty with a head or foot injury for a moderate distance (50 to 300 meters).

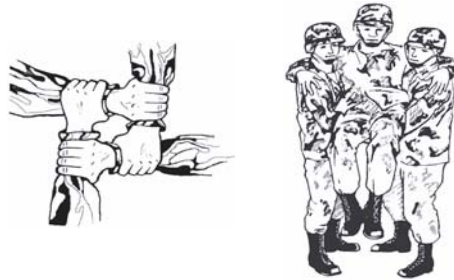

- (e) The two-hand seat carry is used when carrying a casualty for a short distance (up to 50 meters) and in placing a casualty on a litter.

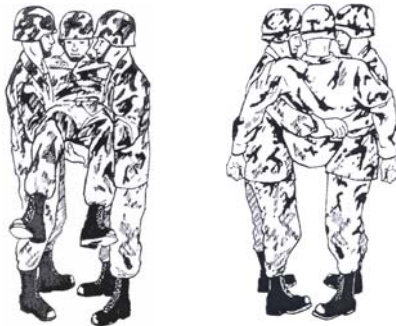

Special Manual Evacuation Techniques

Special Manual Evacuation Techniques, The use of special techniques are required to remove injured soldiers from tanks, other armored vehicles, motor vehicles, or from other limited-access positions.

CAUTION: Parking next to a battle-damaged tank can draw antitank fire to the ambulance. If there is the potential for enemy fire, approach from the opposite side of the vehicle, using all available cover and concealment. Ambulance teams should park the vehicle behind protective terrain and dismount with the necessary equipment to provide emergency medical treatment to include stabilization of the head and spine, when required.

Observing the vehicle for fire

- (1) Exercise extreme caution when approaching a burning vehicle
- (2) Use fire suppression equipment and any protective measures available
- (3) In some cases, attempting to save the crew of a burning vehicle may only result in the injury or death of the rescuer. This must be a rescuer's decision based on the specific circumstances.

The procedures for extracting a casualty include

- (1) Gaining access to the casualty
- (2) Administering lifesaving measures
- (3) Freeing the casualty from the vehicle or other limited-access positions
- (4) Preparing the casualty for removal
- (5) Transporting the casualty from the site

Evacuating a casualty from a tank

- (1) Steps in Casualty Evacuation
 - (a) Observe the vehicle for fire
 - (b) Stabilize head and neck if possible
 - (c) Extract the casualty from the vehicle
 - (d) Check and treat the casualty
 - (e) Evacuate the casualty
- (2) Vehicle Exit Procedures
 - (a) The M1 is equipped with three exits. Some of these exits are used to evacuate specific crew members while others are used to evacuate any of the crew.
 - (b) The exits are:
 - (i) Commander's hatch
 - (ii) Loader's hatch
 - (iii) Driver's hatch
- (3) Removing a wounded soldier from the interior of a tank is difficult and requires speed (as there is the potential that a damaged tank

- may explode or the tank may be more easily acquired/targeted by the enemy)
- (4) Whenever possible, crew members should be used to extract casualties from tanks because of their experience with these vehicles
 - (5) Removing casualties from a tank requires 3 crew members/soldiers

Steps taken by medical personnel prior to the casualty being extricated

NOTE: Rescuers should always attempt to stabilize the injured soldier's head and neck prior to moving him.

- (1) If a head and or spine injury are suspected-
 - (a) Medical personnel will stabilize the neck as much as possible prior to attempting to extract the casualty
 - (b) The neck should be stabilized using a cervical collar, Kendrick's Extrication Device (KED)
 - (c) Manual stabilization (using forearms of the rescuer, as appropriate when no equipment is available)
- (2) Depending upon the tactical situation, these procedures may be abbreviated if the vehicle and its crew are in imminent danger

NOTE: Rescuers should always attempt to stabilize the injured soldier's head and neck prior to moving him.

TERMINAL LEARNING OBJECTIVE

Given a CMVS, immobilization splints and equipment and documentation forms. You encounter a casualty who requires medical treatment. Casualty must be extricated and removed from the immediate area. Initial assessment of casualty is not completed.

Standard litters

- (1) Standard collapsible litter is most widely used. It folds along the long axis only.
 - (a) Basic components of the litter
 - (i) Two straight, rigid, lightweight aluminum poles
 - (ii) A cover (bed) of cotton duck
 - (iii) Four wooden handles attached to the poles
 - (iv) Four stirrups (one bolted near the end of each pole) The stirrups support the litter when it is placed on the ground
 - (v) Two spreader bars (one near each end of the litter) These bars are extended crosswise at the stirrups to hold the cover taut when the litter is open
 - (vi) Two litter securing straps (one attached to each pole at the stirrup bolts) These straps are used to secure the litter when it is closed
 - (vii) Accessories such as patient securing straps
 - (b) Dimensions of the standard collapsible litters are as follows:
 - (i) Overall length is 90 inches
 - (ii) Overall width is 22 7/8 inches
 - (iii) Bed length is 72 inches
 - (iv) Bed width is 22 7/8 inches
 - (v) Weight is 15 pounds

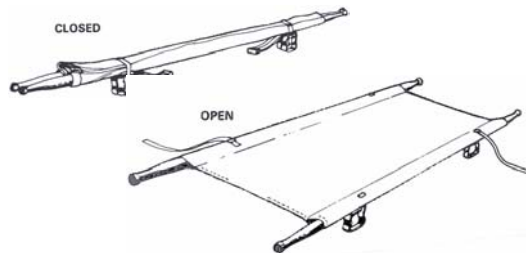

- (2) The patient securing strap is used to hold the patient in position on the litter
- (a) Designed to fit the straight and folding aluminum litters as well as other standard litters
 - (b) Available in quantities of four per litter
 - (c) Strap can also be used with an improvised litter as a patient restraint, if required
 - (f) Made from 6-foot length of 2-inch webbing and a buckle with a locking device and spring



- (3) Folding aluminum litter
- (a) Folding lightweight aluminum poles
 - (b) Poles can be folded to one-half their length when litter is not in use
- (4) Poleless semirigid litter
- (a) Useful in evacuating patients from ships and in mountainous areas
 - (b) Holds the patient securely in position and facilitates the movement of patient in vertical position
 - (c) Dimensions of litter are overall length, 83 3/4 inches; overall width, 22 3/4 inches; and it weighs 18 3/4 pounds. Basic components are:
 - (i) Semirigid cotton duck with wooden supports
 - (ii) Four webbing handles (two at each end). These straps can be used when the litter is carried by four bearers.
 - (iii) Four loops - used to insert the poles for carrying
 - (iv) Headpiece - used to support casualty's head
 - (v) Seven patient securing straps - used to secure patient to litter
- (5) Poleless nonrigid litter
- (a) Folded and carried by combat medic
 - (b) Has folds into which improvised poles can be inserted for evacuation over long distances
 - (c) Slings for hoisting, lowering, and carrying, patient securing straps to secure the patient to the litter
- (6) Stokes litter
- (a) Affords maximum security for the patient when litter is tilted
 - (b) Dimensions and basic components and their functions:

- (i) Composed of steel or aluminum tubular frame supporting a bed of wire mesh netting. Also has wooden slats to support patient's back.
 - (ii) Lower half is divided into two compartments to accommodate patient's legs
 - (iii) Four webbed patient securing straps for use in securing patient
 - (iv) Ropes, cables, or steel rings that can be attached to litter as required for vertical recoveries
 - (v) Dimensions are length, 84 inches; width, 23 inches; and weight, 31 1/2 pounds
- (7) SKED litter
- (a) Compact and lightweight transport system used to evacuate a patient over land
 - (b) May also be used to rescue a patient in water

Improvised litters

NOTE: There are times when a patient may have to be moved and a standard litter is not available. The distance may be too great for manual carries or the patient may have an injury that would be aggravated by manual transportation. In these situations, litters can be improvised from materials at hand. Improvised litters must be as well constructed as possible to avoid the risk of dropping or further injuring the patient. Improvised litters are emergency measures and must be replaced by standard litters at the first opportunity.

- (1) Many different types of litters can be improvised, depending upon materials available
- (a) Satisfactory litter can be made by securing poles inside such items as:
 - (i) Blanket
 - (ii) Poncho
 - (iii) Shelter half
 - (iv) Tarpaulin-Material such as waterproof canvas
 - (v) Mattress cover
 - (vi) Jackets
 - (vii) Shirts
 - (viii) Bedticks, bags, and sacks
 - (b) Poles can be improvised from:
 - (i) Strong branches
 - (ii) Tent poles
 - (iii) Skis
 - (iv) Lengths of pipe
 - (c) Most flat-surface objects of suitable size can be used as litters
 - (i) Doors
 - (ii) Boards
 - (iii) Window shutters
 - (iv) Benches

- (v) Ladders
- (vi) Cots
- (vii) Chairs

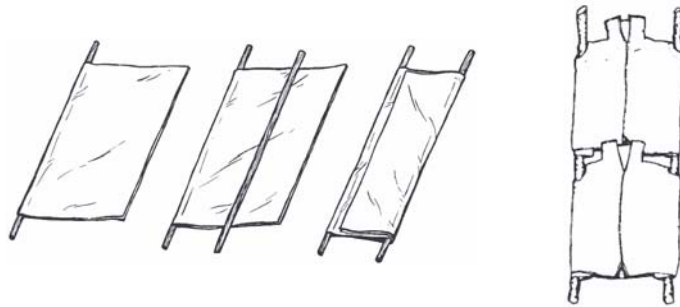

Chemical litters

- (1) Cover fabric is honeycomb weave of monofilament polypropylene
- (2) Will not absorb agent and is not degraded by decontamination fluids
- (3) Flame retardant and rip resistant
- (4) Treated to withstand weather and sunlight
- (5) Aluminum poles, painted with chemical agent resistant coating
- (6) Conforms to all NATO standards and weights about 15 pounds

Dress a litter

NOTE: A litter is dressed with one, two, or three blankets to reduce danger of shock and to afford warmth and comfort during transport.

Dress with one blanket

- (1) Place blanket diagonally over litter
- (2) After casualty is placed on litter, bring sides of blanket over casualty and tuck edges at head and feet

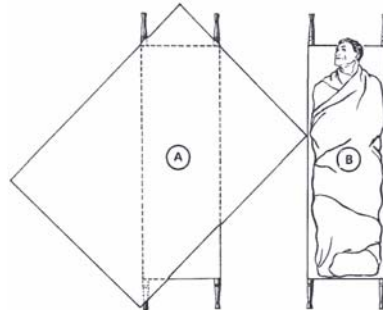

Dress with two blankets

- (1) Place first blanket lengthwise across litter with blanket edge just beyond head end of litter
- (2) Second blanket is folded in third, lengthwise, and placed over the first blanket - open folds about 2 feet from foot end
- (3) After casualty is placed on litter, bring bottom of blanket up over casualty's feet. Leave a small fold between feet.
- (4) Tuck two folds closely over and around feet and ankles
- (5) Open folds on second blanket about 2 feet from foot end
- (6) After casualty is placed on litter, bring bottom of blanket up and over patient's feet
- (7) Leave small fold between feet
- (8) Tuck two folds closely over and around feet and ankles
- (9) Wrap casualty with one side and then opposite side of first blanket

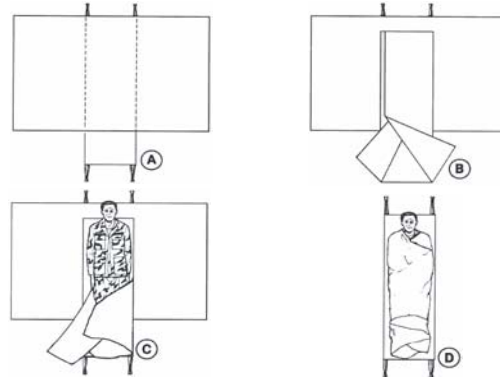

Dress with three blankets

- (1) Place first blanket on litter lengthwise so that one edge is even with litter pole farthest from you
- (2) The upper end of blanket is even with head of canvas
- (3) Fold blanket back upon itself once, so that the folded edge is along litter pole near you and outer edge of blanket overhangs the other pole
- (4) Place second blanket lengthwise over first one as described above, except start with opposite litter pole so that the blanket overhang is on opposite side of first blanket
- (5) After casualty is placed on litter, fold third blanket once lengthwise and place it over casualty with one end under chin
- (6) Fold overhanging edges of first two blankets over third blanket and secure them in place with safety pins, if available, or securing straps

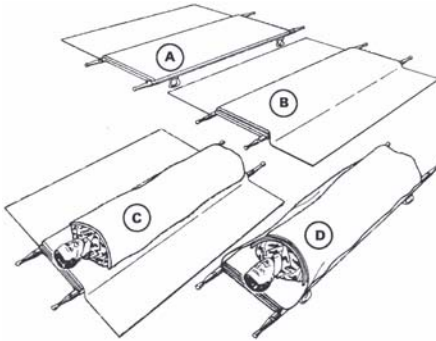

Use of patient securing straps

Used after casualty is placed on dressed litter and covered

Used to hold casualty in position

Number of straps and body parts over which they should be placed depend upon type of terrain over which casualty is carried

- (1) If two straps are necessary
 - (a) Put one strap across chest and one across legs just below the knees
 - (b) Extend straps under litter and buckle against litter pole
- (2) If terrain is rough
 - (a) Apply two additional straps
 - (b) One placed across waist and other across thighs
 - (c) Extend straps under litter and buckle them against litter pole

- (3) If casualty is carried either up or down steep slopes
 - (a) Use two additional straps
 - (b) Secure each thigh to litter separately
 - (c) Take one strap over one thigh, under other thigh, then under litter and buckle it against the litter pole
 - (d) Take remaining strap and secure opposite thigh in same manner

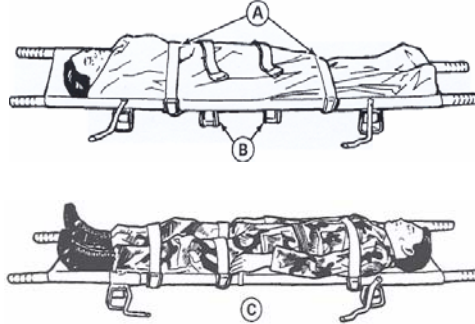

Identify the general rules for litter bearers

General rules for litter bearers

- (1) In moving a casualty, the litter bearers must make every movement deliberately and as gently as possible. The command STEADY should be used to prevent undue haste.
- (2) The rear bearers should watch the movements of the front bearers and time their movements accordingly to ensure a smooth and steady action
- (3) The litter must be kept as level as possible at all times, particularly when crossing obstacles, such as ditches
- (4) Normally, the casualty should be carried on the litter feet first, except when going uphill or upstairs; his head should then be forward. If casualty has a fracture of a lower extremity, he should be carried uphill or upstairs feet first and downhill or downstairs head first to prevent the weight of body from pressing upon injured part.
- (5) When casualty is loaded on litter, his individual equipment is carried by two of the bearers or placed on litter

NOTE: For balance and support when lowering a litter, each bearer places free hand on other knee that remains in an upright position.

Use Spine Boards and the Kendrick's Extrication Device (KED)

NOTE: Spine boards and the KED aid in rescuing and immobilizing casualties with known or suspected spinal fractures. Spine boards can be prefabricated from plywood or any suitable material.

Short spine board

- (1) Casualty has a fracture or suspected fracture of neck
- (2) Applied from waist up to immobilize upper spine before moving
- (3) Bearers assemble required items:
 - (a) Short spine board
 - (b) Cervical collar
 - (c) Two 6-foot patient securing straps
 - (d) Cravat

NOTE: If an item is not available, the bearers should improvise it from any available material

Kendrick's Extrication Device (KED)

- (1) Prefabricated flexible type of short spine board
- (2) Useful in extricating casualty suspected of having spinal injuries, especially if casualty is in the sitting position
 - (a) Bearer 1 maintains inline stabilization until KED completely applied
 - (b) Bearer 2 applies rigid cervical collar
 - (c) Bearer 3 ties hands of casualty together and place casualty on long board

Long spine board

- (1) Casualty has a fracture or suspected fracture of back as well as neck
- (2) Bearers assemble required items
 - (a) Long spine board
 - (b) Four 6-foot patient securing straps
 - (c) Cravat
 - (d) Four pieces of padding

TERMINAL LEARNING OBJECTIVE

You encounter casualty(ies) that has/have been assessed and injury(ies) prioritized. A field medical card (FMC) has been initiated and attached to the casualties' uniform. Casualty(ies) require(s) evacuation to the next echelon of care.

Review Army Ground Ambulances and assigned medical personnel

General

- (1) Ground ambulances are vehicles designed for or converted to carrying patients
 - (a) They are dedicated assets to be used solely for the medical mission
 - (b) They may be organic to the combat battalion in which the driver and aidman are assigned
 - (c) These vehicles are equipped with a Medical Equipment Set designed for use in these ambulances, it consists of
 - (i) The Aidman's Aid Bag or CMVS
 - (ii) Long and short back boards, KEDs, and Cervical stabilization equipment
 - (iii) Supplemental Oxygen and suction equipment
 - (iv) Litters, patient securing straps and a blanket set
 - (d) They are staffed with a driver/medical aidman and an additional medical aidman who are both qualified in basic EMT procedures
 - (e) Track ambulances are staffed with three medical personnel (ambulance driver, track commander, and medical aidman)

Advantages

- (1) They are co-located with maneuver elements and readily available when needed
- (2) Operation is not limited by inclement weather

Responsibilities for loading

- (1) Ambulance drivers are MOS qualified medics, their duties and responsibilities include but are not limited to the following:
 - (a) Responsible for the ambulance at all times
 - (b) Driver maintenance of the vehicle and reporting of major deficiencies to their section chief or supervisor
 - (c) Providing emergency medical care as necessary
 - (d) Providing maximum safety and welfare to the patients entrusted to their care
 - (e) Ensuring the operational readiness and responsiveness of their vehicle and equipment
 - (i) Litters
 - (ii) Blankets
 - (iii) Splints
 - (iv) Medical expendables
 - (v) Oxygen canisters

- (vi) Flashlights
- (vii) Auxiliary fuel
- (viii) Decontamination equipment
- (ix) Special medical materials and equipment
- (f) Ensuring they have the required information, tools, and equipment to navigate to the pick-up location. This includes:
 - (i) Maps
 - (ii) Map coordinates
 - (iii) Map overlays
 - (iv) Compass and position locator equipment such as GPS
- (g) Preparing the ambulance for loading and unloading
- (h) Assisting litter bearers in the loading and unloading of patients
- (i) Performing property exchange when patients are loaded or unloaded
- (j) Providing emergency transport of medical personnel, medical supplies, and blood and blood products
- (k) Acting as a messenger in medical channels
- (2) The medical aidman's duties and responsibilities include:
 - (a) Assistant driver
 - (b) Familiarity with the condition of each patient being transported and reviewing the information on the Field Medical Card (FMC)
 - (c) Coordination with the individual in charge for any special instructions in the care and treatment of patients en route
 - (d) Providing Emergency Medical Treatment as required
 - (e) Making periodic checks of patients while en route
 - (f) Supervising and assisting in loading and unloading of the ambulance
 - (g) Assisting the driver with land navigation and guiding the driver when backing or moving off roads, or when under blackout conditions

Ground Ambulances

- (1) Vehicles designed or modified as ambulances include field (wheel) ambulances, and the M13 (track) armored personnel carrier
 - (a) Military field ambulances are designed for use by field units, they can operate on:
 - (i) Paved and secondary roads, trails, and cross country terrain
 - (ii) They must possess mobility and survivability comparable to the units being supported
 - (b) Current field ambulance variations include (These ambulances are normally used to evacuate patients from front line units to Battalion Aid Stations)
 - (i) Truck Ambulances, 4x4 utility HMMWV (M996 and M997) casualty carrying capacity

- * M996: 2 litter or 6 ambulatory or 1 litter and 3 ambulatory
- * M997: 4 litter or 8 ambulatory or 2 litter and 4 ambulatory
- (ii) Carrier personnel, Full tracked, Armored, M113, T113E2 (when configured with a litter kit, an NBC kit, and an MES, is classified as a standard evacuation vehicle) carrying capacity
 - * 4 litter or 10 ambulatory or a combination of the two

Ambulance loading and unloading

- (1) In loading and unloading ambulances litter casualties are moved carefully so as not to cause additional discomfort and or injury. Procedures may vary depending on the number of litter bearers, the presence or absence of a medical aidman, and the type of vehicle used
 - (a) General Procedures
 - (i) Casualties are normally loaded head first for the following reasons
 - * They are less likely to experience motion sickness or nausea
 - * They experience less noise from doors opening and closing
 - * Less danger of further injury in the event of a rear collision
 - (ii) When a casualty requires en route care
 - * For an injury to one side of the body it may be necessary to load the casualty feet first to make the injury readily accessible
 - * For casualties that require I.V. therapy a lower berth may be indicated in order to obtain a gravity flow
 - * Casualties with bulky splints may also require a lower berth (if possible)
 - (b) Instructional procedures: For loading and unloading ambulances
 - (i) Litter bearers are numbered
 - (ii) Formal commands are given so that each individual can learn his particular job and work as a team
 - (c) Loading procedures
 - (i) Loading Sequence for four litter casualties
 - * Upper right
 - * Lower right
 - * Upper left
 - * Lower left
 - (ii) The most seriously injured are loaded last so that they will be the first to be off-loaded

- (iii) A three man squad is required to load and unload the ambulance

Review of medical air ambulances

General

- (1) Aeromedical evacuation is accomplished by both helicopter and fixed wing aircraft
- (2) Dedicated Aeromedical evacuation assets permit en route casualty care. This care minimizes further injury to the casualty and decreases mortality.

Advantages of Aeromedical evacuation

- (1) The speed with which the casualty can be evacuated by air to a Medical Treatment Facility (MTF) ensures timeliness of treatment and contributes to:
 - (a) Saving lives
 - (b) Reducing permanent disability
 - (c) Increases the number of casualties returned to duty
- (2) The range and speed of aircraft make it possible to evacuate casualties over long distances in short periods of time
- (3) Helicopters can move casualties over terrain where evacuation by other means would be difficult if not impossible
- (4) Because of speed, range, flexibility, and versatility of Aeromedical evacuation, casualties can be moved to MTFs best equipped to deal with their condition
- (5) The selectivity of use of MTFs made possible by Aeromedical evacuation procedures permits
 - (a) Economy in the use of these facilities
 - (b) Fewer specialty treatment teams are required because Aeromedical evacuation assets allow the casualty to be evacuated directly to where they are located
 - (c) Hospitals are required to move less often thereby reducing their periods of noneffectiveness during movement and reestablishment

Responsibilities for loading

- (1) It is the responsibility of the commander who initiated the evacuation request to have the casualty delivered to the landing site for loading aboard the aircraft
- (2) The actual loading is supervised by Aeromedical evacuation personnel
- (3) The soldier medic on the ground will direct litter teams to move casualties in concert with the air ambulance crew member directing approach to and loading of the aircraft

Army Rotary Wing Air Ambulances

- (1) Helicopters are rotary-wing aircraft that are capable of:
 - (a) Horizontal flight

- (b) Vertical flight
- (c) Lateral flight
- (d) Hovering flight
- (2) Their ability to circumvent terrain and obstacles, and the minimum requirements for takeoff and landing enable them to operate from areas inaccessible to fixed-wing aircraft or surface vehicles
- (3) The helicopter's capability of flight at relatively slow speeds permits operations during periods of reduced ceiling and visibility
- (4) Helicopters are organic to the air ambulance units and aviation units of the division and corps
- (5) Military helicopters are designated by a combination of letters and numbers that are used to identify the basic mission and type:
 - (a) Observation helicopter (OH)
 - (b) Utility helicopter (UH)
 - (c) Cargo/transport helicopter (CH)
- (6) The last two classes of helicopters can be used for the air evacuation of litter patients
- (7) Army Medical air ambulances
 - (a) The UH-60A Blackhawk: This helicopter is used as the primary dedicated air ambulance
 - (i) Normal evacuation configuration
 - * Four litter patients and one ambulatory patient
 - (ii) Maximum evacuation configuration
 - * Six litter patients and one ambulatory patient
 - * Or seven ambulatory patients
 - (b) The UH-1H/V Iroquois: This aircraft also is used as a dedicated air ambulance
 - (i) Normal evacuation configuration
 - * Three litter and four ambulatory patients
 - (ii) Maximum evacuation configuration
 - * Six litter patients or nine ambulatory patients

Helicopter Landing Sites

- (1) The unit requesting Aeromedical evacuation support is responsible for selecting and properly marking the helicopter LZ
- (2) Criteria for Landing Sites
 - (a) The helicopter LZ and the approach zones to the area should be free of obstructions
 - (b) Sufficient space must be provided for the hovering and maneuvering of the helicopter during landing and takeoff
 - (c) The approach zones should permit the helicopter to land and take off into the prevailing wind whenever possible

- (d) Landing sites should afford helicopter pilots the opportunity to make shallow approaches
- (3) Definite measurements for LZs cannot be prescribed since they vary with
 - (a) Temperature
 - (b) Altitude
 - (c) Wind
 - (d) Terrain
 - (e) Loading conditions
 - (f) Individual helicopter characteristics

NOTE: The minimum requirement for light helicopters is a cleared area of 30 meters in diameter with an approach and departure zone clear of obstructions

- (4) Removing or Marking Obstructions
 - (a) Any object (paper, cartons, ponchos, blankets, tentage, or parachutes) likely to be blown about by the wind from the rotor should be removed from the landing area
 - (b) Obstacles, such as cables, wires, or antennas at or near LZs, which cannot be removed and may not be readily seen by a pilot, must be clearly marked
 - (c) Red lights are normally used at night to mark all obstacles that cannot be easily eliminated within a LZ
- (5) In most combat situations, it is impractical for security reasons to mark the tops of obstacles at the approach and departure ends of a LZ
- (6) If obstacles or other hazards cannot be marked, pilots should be advised of existing conditions by radio. In a training situation or at a rear area LZ, red lights should be used whenever possible to mark obstructions.

Identifying the Landing Site

- (1) When the tactical situation permits, a landing site should be marked with the letter "H" or an inverted "Y, " using identification panels or other appropriate marking material

NOTE: Special care must be taken to secure panels to the ground to prevent them from being blown about by the rotor wash. Firmly driven stakes will secure the panels tautly; rocks piled on the corners are not adequate.

- (2) If the tactical situation permits, the wind direction may be indicated by a Small wind sock or rag tied to the end of a stick in the vicinity of the LZ. The man standing at the upwind edge of the site with his back to the wind and his arm extended forward.
- (3) Smoke grenades that emit colored smoke as soon as the helicopter is sighted. Smoke color should be identified by the aircrew and confirmed by ground personnel.
- (4) In night operations. the following factors should be considered:

- (a) One of the preferred methods to mark a landing site for aircrews using NVGs is to place a light such as an infrared chemical light at each of the four corners of the usable LZ
- (i) These lights should be colored to distinguish them from other lights which may appear in the vicinity. A particular color can also serve as one element in identifying the LZ.
 - (ii) Flare pots or other types of open lights should only be used as a last resort. They usually are blown out by the rotor downwash. Further, they often create a hazardous glare or reflection on the aircraft's windshield.
 - (iii) The site can be further identified using a coded signal flash to the pilot from a ground operator. This signal can be given with the directed beam of a signal lamp, flashlight, vehicle lights, or other means.
 - (iv) When using open flames, ground personnel should advise the pilot before he lands. Burning material must be secured in such a way that it will not blow over and start a fire in the LZ.

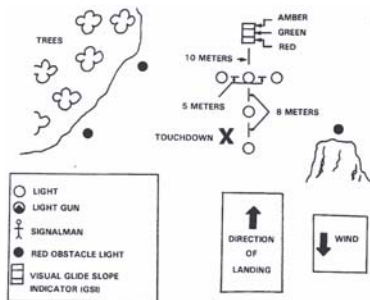

NOTE: Precautions should be taken to ensure that open flames are not placed in a position where the pilot must hover over or be within 3 meters of them.

- (v) All lights are displayed for only a minimum time before arrival of the helicopter. The lights are turned off immediately after the aircraft lands. Blue and green light sources should only be used as a last resort; the filter on the NVGs may make them difficult to detect.
- (vi) When standard lighting methods are not possible, pocket-sized white (for day) or amber (for night) strobe lights are excellent means to aid the pilot in identifying the LZ.

- (vii) During takeoff, only those lights requested by the pilot are displayed; they are turned off immediately after the aircraft's departure.
- (viii) When the helicopter approaches the LZ the ground contact team can ask the pilot to turn on his rotating beacon briefly. This enables the ground personnel to identify the aircraft and confirm its position in relation to the LZ.

Loading patients aboard rotary-wing aircraft

- (1) Responsibility for Loading and Securing.
 - (a) The pilot is responsible for ensuring that the litter squad follows the prescribed methods for loading and securing litters and related equipment.
 - (b) The final decision regarding how many patients may be safely loaded rests with the pilot.
- (2) Guides for Loading Patients.
 - (a) Litter patients should be positioned in the helicopter according to the nature of their injuries or condition. Personnel aboard the aircraft supervise the loading and positioning of the patients. Normally, the helicopter has a crew of four. The crew consists of a pilot in command (PC), copilot (PI), crew chief, and flight medic.
 - (b) The most seriously injured patients are loaded last on the bottom pans of the litter support unit. However, if it is anticipated that a patient's medical condition may require in-flight emergency medical care (such as cardiopulmonary resuscitation), he should be loaded onto either of the top pans to facilitate access to him.
 - (c) The structuring of the litter support unit allows patients to receive IV fluids and oxygen in flight. Patients receiving IV fluids can be placed on any of the litter pans, depending on their injuries or condition.
 - (d) Patients in traction splits should be loaded last and on a bottom pan
 - (e) The UH-60A has the capability to be loaded on both sides simultaneously.
 - (f) Patients should be loaded so that upon rotating the litter support, the patient's head will be forward in the cabin. To accomplish this:
 - (i) patients loaded on the left side of the aircraft should be loaded head first
 - (ii) patients loaded on the right side of the aircraft should be loaded feet first

Safety Measures

- (1) When loading and unloading a rotary-wing aircraft, certain precautionary measures must be observed

CAUTION: Failure to observe proper safety procedures could cause severe injury or death.

- (2) Litter bearers must present as low a silhouette as possible and must keep clear of the rotors at all times
- (3) The helicopter must not be approached until a crew member signals to do so
- (4) The litter bearers should approach the aircraft at a 45-degree angle from the front of the helicopter
- (5) If the helicopter is on a slope and conditions permit, loading personnel should approach the aircraft from the downhill side. Directions given by the crew must be followed, and litters must be carried parallel to the ground
- (6) Smoking is not permitted within 50 feet of the aircraft

Non medical vehicles used for casualty evacuation or medical evacuation

General

- (1) In combat areas, ambulances are often not available, are too few in number, or are incapable of evacuating casualties over certain types of terrain
- (2) Many vehicles available to most units can be used to transport casualties with little or no change in their configuration
- (3) Some amphibious cargo and personnel vessels can be used for this purpose; however, their casualty carrying capacity varies
- (4) When casualties have entered the CHS system, they are classified as patients. Patient evacuation includes providing en route medical care to the patient being evacuated.
- (4) A casualty moved on a non medical vehicle without en route medical care, is considered to be transported not evacuated

Casualty Transport and patient evacuation in a mass casualty situation

- (1) To provide timely and responsive evacuation or casualty transport, CHS planners develop proactive Operation Plans (A Detailed plan of how the operation is to be conducted) to meet the challenges of mass casualty situations
 - (a) Contingency plans should identify-
 - (i) Non medical transportation resources
 - (ii) Non medical personnel for litter teams
 - (iii) Evacuation routes
 - (iv) Ambulance exchange points
 - (v) Medical personnel resources to provide en route medical care on non medical vehicles
 - (vi) Capabilities and locations of MTFs
 - (vii) Communications frequencies and call signs for C2
 - (viii) Procedures for medical equipment exchanges
 - (ix) Ground non medical assets, all available ground vehicles to augment the medical evacuation assets in an emergency

- (x) Staffing of non medical vehicles with medical personnel
 - (xi) Management of patient evacuation
- (2) Ground non medical assets that can be used for casualty transport (All available ground vehicles should be considered for use when medical evacuation assets are overwhelmed in emergency)
- (a) Bradley infantry fighting vehicle, M2/3
 - (b) Truck, cargo, medium tactical vehicle (MTV), long wheelbase (LWB), 5 ton, M1085
 - (c) Truck, cargo 2 1/2 ton, M35
 - (d) Truck, cargo, heavy expanded, mobile tactical truck (HEMTT), 8x8, cargo, M997
 - (e) Truck, cargo, MTV, light vehicle air drop/air delivery (LVAD/AD), 5 ton M1093
 - (f) Truck, cargo, light medium tactical vehicle (LMTV), air drop/delivery, 2 1/2 ton, M1081
 - (g) SemiTrailer, Cargo, 22 1/2 Ton, M871
 - (h) Armored personnel carrier, M113
 - (i) Tractor, 5 ton, with stake and platform trailer
 - (j) High-mobility, multipurpose wheeled vehicle, M998

United States Army and Air Force Medical and Non medical Aircraft

The US Army has both fixed-wing and rotary-wing aircraft. These aircrafts are employed in both the combat zone and echelons above the Corps level.

- (1) Army Fixed-Wing Aircraft: The capability of Army fixed-wing aircraft to land on and take off from selected small, unprepared areas permits the evacuation of patients from Areas of Operations which would be inaccessible to larger aircraft
- (2) These aircraft can fly slowly and maintain a high degree of maneuverability
- (3) This capability further enhances their value in forward areas under combat conditions
- (4) Army fixed-wing aircraft are limited in speed and range as compared with larger transport-type aircraft
- (5) When adequate airfields are available, fixed-wing aircraft may be used in forward areas for patient evacuation

NOTE: This is a secondary mission for these aircraft which will be used only to augment dedicated air ambulance capabilities.

Types of Army fixed-wing non-medical aircraft suitable for patient evacuation

- (1) The U-21 Ute and C-12 Huron are used as utility (U-21) and passenger/cargo (C-12) aircraft. These aircraft are not normally employed as evacuation aircraft. In emergency situations, both of these aircraft can be configured to evacuate litter and ambulatory patients

- (a) The U-21 Ute is a twin turbine, propeller-driven utility aircraft with a normal cruise speed of 210 knots and an endurance of over 5 hours flying time. It is capable of accommodating ten ambulatory patients, or three litter patients plus three ambulatory patients and a medic
- (b) The C-12 Huron is the newest addition to the Army's fixed-wing aircraft inventory. Depending on the model, its normal cruise speed ranges from 240 to 260 knots with 5 to 6 hours endurance. It is capable of carrying eight ambulatory patients, or two litter and four ambulatory

Loading Patients Aboard Army Fixed-Wing Aircraft

- (1) The personnel who transport patients to the landing strip load the patients aboard the aircraft
- (2) They may be required to assist in configuring the aircraft for litters
- (3) Litters are generally loaded from the top downward and from the front to the rear
- (5) The four-man litter squad plus the crew chief normally load these aircraft

The crew chief or another member of the aircraft crew supervises the loading of all patients. Bearer number 2 normally enters the aircraft to assist the crew chief in loading the litters

Army rotary-wing non-medical aircraft suitable for patient evacuation

- (1) The CH-47 (Chinook) helicopter, has a capacity of 24 litter patients, or 31 ambulatory patients, or a combination of litter and ambulatory patients
- (2) The aircraft's overall size and rotor blade diameter make it unsuitable for use in smaller or more confined areas

NOTE: The CH-47 helicopter should not be brought into a LZ that is smaller than 40 meters in diameter.

Loading Patients Aboard the CH-47 (Chinook)

- (1) This helicopter's maximum capacity is 24 litter patients or 31 ambulatory patients. The 31 ambulatory patients are seated in the ten 3-man seats and the 1-man seat as shown in Figure 10-42 of FM 8-10-6. The two 1-man seats are used by crew members.
- (2) When carrying 24 litter patients, the seats are replaced with six tiers of litters, four litters high. The two 1-man seats in the rear section should remain in place for the crew members. The 1-man seat at the left front may also be left in place provided it is needed.

- (3) The combinations of litter and ambulatory patients the CH-47 is capable of accommodating are provided in Table 10-5 of FM 8-10-6

In order to accommodate litter casualties the CH-47 must be re-configured using specially designed litter support kits

- (1) Litter Support Kits. These kits are available for use in adapting the helicopter's interior to evacuate litter patients.
- (2) These kits contain 12 litter poles, stored in the front of the cargo compartment and 12 litter traps, stored in overhead recesses.
- (3) The poles contain safety attachments for securing them along the side walls of the compartment. The pull-down straps on the aisle side are secured to floor studs.
- (4) Permanently attached to each litter pole and each strap are four litter support brackets with locking devices for securing litter handles in place
- (6) It is not necessary to remove the seats before adapting the compartment for litter patients. The seats can be folded against the wall and strapped in place.

Loading of Litter Patients. The loading of litter patients aboard the CH-47 helicopter is similar to loading patients aboard the UH-1H air ambulance except the litter squad is not assisted by the crew members.

- (1) In a 2-man carry, the litter squad carries each litter patient through the lowered rear door and ramp to the litter rack where he is to be placed
- (2) The squad then moves into a 4-man carry and places the litter patient into the appropriate tier
- (3) The litter racks should be loaded from front to rear and from top to bottom
- (4) Litter patients requiring in-flight medical care should be positioned to facilitate this care. If the helicopter is to be loaded with a combination of litter and ambulatory patients, the litter patients should be positioned to the rear of the ambulatory patients whenever possible.

Air Force aircraft: Most USAF cargo aircraft can be used for AeroMedical Evacuation(AE). The aircraft used for forward airlift movement of troops and supplies may be reconfigured for the AE mission on the return flight (provided proper equipment is available).

- (1) However, more likely USAF AE will be accomplished by dedicated (aircraft identified for AE only) or designated (mission scheduled specifically for AE) AE aircraft
- (2) The flexibility and responsiveness provided to AE by designated or dedicated AE missions also improves cargo and passenger airlift

throughput by not pulling scheduled cargo missions from their scheduled routes to support AB

Types of Air Force Transport Aircraft

- (1) The C-130 Hercules Transport. This aircraft is a four-engine, turbo-propeller driven aircraft with a pressurized, air-conditioned cabin and a self-contained loading ramp.
 - (a) In the normal patient configuration, this aircraft can accommodate 50 litter and 27 ambulatory patients
 - (b) This can be varied for as many as 70 litters with no ambulatory patients, or 85 ambulatory patients with no litters
 - (c) These figures represent maximum patient capacity and would not be used routinely
 - (d) The medical crew is normally provided by the USAF. It consist of:
 - (i) Two flight nurses
 - (ii) Three AE technicians
 - (e) The C-130 can land on and take off from short, austere runways
 - (f) It can also be used on landing strips such as those found in forward base operations. Its normal use is within a TO for tactical and assault airlift
 - (g) The ambulance bus maybe backed up to the ramp at the tail of the aircraft for easy enplaning of litter patients
 - (h) The C-130 can also be used for inter-theater airlift missions

- (2) The C-9A Nightingale. This aircraft is a T-tailed aeromedical airlift with two jet engines and a pressurized, air-conditioned cabin.
 - (a) The Nightingale is the military version of the DC-9 airliner with an interior specifically designed for in-flight patient care
 - (b) It is the only aircraft in the USAF inventory that is dedicated to the medical evacuation mission
 - (c) It has a self-contained patient enplaning ramp and can accommodate 40 litter patients, 40 ambulatory patients, or a combination of both
 - (d) The ambulance bus maybe backed up to the ramp at the tail of the aircraft for easy enplaning of litter patients
 - (e) This aircraft can operate from and between CZ, BAC, or CONUS from improved mile long runways
 - (f) The medical crew normally consists of:
 - (i) Two flight nurses
 - (ii) Three AB technicians

- (3) The C-141 Starlifter. This aircraft is a four-engine, jet cargo transport aircraft. The cabin is pressurized, heated, or cooled, as required
 - (a) The ambulance bus may be backed to the ramp at the tail of the aircraft for easy planing of litter patients

- (b) The C-141 can accommodate 103 litter patients, 147 ambulatory patients, or a combination of both
 - (c) Normally, the aircraft will be configured to accommodate 48 litters and 38 seats. Maximum capacity is not routinely used, as crowding detracts from patient care.
 - (d) The usual medical crew consists of
 - (i) Two flight nurses
 - (ii) Three AE technicians
 - (e) The C-141 is used for all missions of the AMC intertheater AB system. With the backhaul capacity, these intercontinental cargo aircraft provide AE from a TO to CONUS
- (4) The C-5 Galaxy .The C-5 is the US's largest aircraft. The aircraft is normally a cargo mover, with a payload of over 200,000 pounds.
- (a) If required, it could carry up to 70 ambulatory patients in its upper- aft passenger compartment in addition to its cargo load
 - (b) This aircraft is considered an aircraft of opportunity and is only used if absolutely necessary
- (5) The C-17A. This aircraft is a four-engine, jet driven aircraft with a pressurized, air-conditioned cabin and a self-contained loading ramp.
- (a) In the normal patient configuration, this aircraft can accommodate 36 litter and 54 ambulatory patients. These figures represent maximum patient capacity.
 - (b) The medical crew is provided by the USAF. It consists of:
 - (i) two flight nurses
 - (ii) three AE technicians
 - (c) The C-17 A can land and take off from short, austere runways. It can also be used on landing strips such as those found in forward base operations.
 - (d) When available, the ambulance bus may be backed to the ramp at the tail of the aircraft for easy enplaning of litter patients
 - (e) The C-17 A can also be used for both intratheater and intertheater airlift missions
- (6) The KC-135 and KC-10. These aircraft are four-engine, jet driven aircraft with a pressurized, air-conditioned cabin.
- (a) In the normal patient configuration, this aircraft can accommodate 8 litters and 24 ambulatory patients
 - (b) The litter patients would be loaded and secured to the floor of the aircraft for transport
 - (c) Because these aircraft do not have loading ramps, either a ramp or cargo loader must be used to load and unload patients
 - (d) The medical crews are provided by the USAF

Appendix A
Evacuation Request Procedures
Competency Skill Sheets

Evacuation Request Procedures

Soldiers Name: _____ SSN: _____ CO: _____ TM: _____

Start: _____ Stop: _____ Initial Evaluator: _____

Start: _____ Stop: _____ Retest Evaluator: _____

Start: _____ Stop: _____ Final Evaluator: _____

	1st	2nd	3rd
a. Collected all information needed for the MEDEVAC request line items 1 through 9.	P / F	P / F	P / F
b. Recorded the information using authorized brevity codes, as appropriate.	P / F	P / F	P / F
c. Contacted the unit controlling evacuation.	P / F	P / F	P / F
d. Stated the purpose of the radio message in clear text. (1) State, "I have a MEDEVAC request, over." (2) Wait 1 to 3 seconds for acknowledgment, if there is no answer or if contact is interrupted, repeat the statement.	P / F	P / F	P / F
e. Transmitted the MEDEVAC request information within 3 minutes. (1) The request included all needed information in the proper sequence for transmission. (2) Corrected brevity code items are used. (3) Letters and numbers pronounced IAW appropriate radio telephone procedures. (4) Followed the procedure in the "explanation" column to transmit other required information. (5) Ended the transmission by stating, "Over," and listened for acknowledgement.	P / F	P / F	P / F
f. Kept the radio on and listened for additional instructions or contact from the evacuation unit.	P / F	P / F	P / F

Instructor Comments:

Appendix B
Perform Casualty Triage
Competency Skill Sheets

Triage

Soldiers Name: _____ SSN: _____ CO: _____ TM: _____

Start: _____ Stop: _____ Initial Evaluator: _____

Start: _____ Stop: _____ Retest Evaluator: _____

Start: _____ Stop: _____ Final Evaluator: _____

	1st	2nd	3rd
a. Combat medic examined each patient (1) Conducted quick visual examination (2) Determined which patients are most seriously ill or injured	P / F	P / F	P / F
b. Combat medic treated the most seriously ill or injured first (1) Re-examined their general condition, types of injuries, and need for immediate lifesaving measures (2) Conducted complete enough examination to identify injury or illness, determined priority and type of treatment. Initiated lifesaving treatment as condition indicates	P / F	P / F	P / F
c. Combat medic re-examined each patient (1) Re-examined after all patients have been examined for life-threatening injuries and lifesaving treatment (2) Re-examined for extent of injury or previous non-apparent injury (3) Determined treatment needs	P / F	P / F	P / F
d. Combat medic requested patient evacuation (1) Requested additional evacuation support as needed (2) Established priority for evacuation based on patient category, load, and vehicle availability	P / F	P / F	P / F

Instructor Comments:

Appendix C
Manual Evacuation
Competency Skill Sheets

Fireman's Carry

Soldiers Name: _____ SSN: _____ CO: _____ TM: _____
 Start: _____ Stop: _____ Initial Evaluator: _____
 Start: _____ Stop: _____ Retest Evaluator: _____
 Start: _____ Stop: _____ Final Evaluator: _____

		1st	2nd	3rd
a.	Soldier positioned properly (1) Kneeled at casualties uninjured side (2) Casualties arms placed above his/her head (3) Soldier placed casualties ankle furthest from him over ankle closest to him (4) Soldier placed his one hand on the shoulder farthest from him and the other hand on hip or thigh	P / F	P / F	P / F
b.	Soldier positioned casualty (1) Casualty rolled toward soldier onto abdomen (2) Soldier straddled casualty (3) Soldier placed hands under casualties chest and locked them together (4) Soldier moved backward to raise/lift casualty to knees (5) Soldier continued backward to straighten casualties legs until knees locked (6) Soldier moved forward to place casualty in a standing slightly backward leaning position (7) Soldier maintained support of casualty with one hand. (8) Soldier quickly gasp the casualties wrist with free hand and lifted arm high (9) Soldier placed his head under his raised arm, releasing it as he passed under it (10) Soldier moved quickly to face casualty and secure arms around waist (11) Soldier placed foot between casualties feet and spread them 6-8 inches apart (12) Soldier gasp casualties wrist and raised arm high over head	P / F	P / F	P / F
(d)	Soldier lifted casualty (1) Soldier stooped down and pulled casualties arm over and down over shoulder (2) Brought casualties body across soldier's shoulders and passed arm between casualties legs (3) Soldier grasped casualty's wrist with one hand and the other on his knee for support (4) Soldier stood with casualty correctly positioned.	P / F	P / F	P / F

Instructor Comments:

One-man Support Carry

Soldiers Name: _____ SSN: _____ CO: _____ TM: _____

Start: _____ Stop: _____ Initial Evaluator: _____

Start: _____ Stop: _____ Retest Evaluator: _____

Start: _____ Stop: _____ Final Evaluator: _____

		1st	2nd	3rd
a.	Soldier positioned properly	P / F	P / F	P / F
	(1) Kneeled at casualties uninjured side			
	(2) Casualties arms placed above his/her head			
	(3) Soldier placed casualties ankle furthest from him over ankle closest to him			
	(4) Soldier placed his one hand on the shoulder farthest from him and the other hand on hip or thigh			
	(5) Casualty rolled toward soldier onto abdomen			
	(6) Soldier straddled casualty			
	(7) Soldier placed hands under casualties chest and locked them together			
	(8) Soldier moved backward to raise/lift casualty to knees			
	(9) Soldier continued backward to straighten casualties legs until knees locked			
b.	Soldier provided support	P / F	P / F	P / F
	(1) Soldier raised conscious casualty to standing position			
	(2) Soldier grasped the casualty's wrist			
	(3) Soldier drew casualty's arm around his neck			
	(4) Soldier placed his arm around casualty's waist			

Instructor Comments:

Saddleback Carry

Soldiers Name: _____ SSN: _____ CO: _____ TM: _____

Start: _____ Stop: _____ Initial Evaluator: _____

Start: _____ Stop: _____ Retest Evaluator: _____

Start: _____ Stop: _____ Final Evaluator: _____

		1st	2nd	3rd
a.	Soldier positioned properly	P / F	P / F	P / F
	(1) Kneeled at casualties uninjured side			
	(2) Casualties arms placed above his/her head			
	(3) Soldier placed casualties ankle furthest from him over ankle closest to him			
	(4) Soldier placed his one hand on the shoulder farthest from him and the other hand on hip or thigh			
	(5) Casualty rolled toward soldier onto abdomen			
	(6) Soldier straddled casualty			
	(7) Soldier placed hands under casualties chest and locked them together			
	(8) Soldier moved backward to raise/lift casualty to knees			
	(9) Soldier continued backward to straighten casualties legs until knees locked			
b.	Soldier positioned casualty	P / F	P / F	P / F
	(1) Soldier supported casualty by placing arms around waist			
	(2) Soldier moved to front of casualty			
	(3) Soldier had casualty place encircle arms around soldier's neck and shoulders and lock hands			
	(4) Soldier grasp casualties upper arm with hands while supporting casualty and executed an about face and grasped casualties arm with his hand			
	(5) Soldier stooped and raised casualty onto his back			
	(6) Soldier clasp hands together beneath thighs if required, while casualty holds onto shoulders			

Instructor Comments:

Two Man Seat Carry

Soldiers Name: _____ SSN: _____ CO: _____ TM: _____
Start: _____ Stop: _____ Initial Evaluator: _____
Start: _____ Stop: _____ Retest Evaluator: _____
Start: _____ Stop: _____ Final Evaluator: _____

	1st	2nd	3rd
a. Soldier positioned properly	P / F	P / F	P / F
b. Placed casualty in a supine position	P / F	P / F	P / F
c. Bearers kneeled on opposite sides of the casualty	P / F	P / F	P / F
d. Bearers used hand furthest from the casualty's head to reach and grasp the casualty's shoulder nearest them	P / F	P / F	P / F
e. Bears used free hand to support the casualty's head	P / F	P / F	P / F
f. Bearers brought casualty to a sitting position	P / F	P / F	P / F
g. Bearers moved hands from behind casualty's head to behind casualty's back	P / F	P / F	P / F
h. Bearers interlocked hands behind casualties back	P / F	P / F	P / F
i. Bearers extend casualty's arms and placed them over and behind bearers arms	P / F	P / F	P / F
j. Each bearer placed his hand under the casualty's knees and interlocks hands	P / F	P / F	P / F
k. Bearers stood upon command	P / F	P / F	P / F
l. Bearers demonstrated good body mechanics	P / F	P / F	P / F

Instructor Comments:

Neck Drag

Soldiers Name: _____ SSN: _____ CO: _____ TM: _____
Start: _____ Stop: _____ Initial Evaluator: _____
Start: _____ Stop: _____ Retest Evaluator: _____
Start: _____ Stop: _____ Final Evaluator: _____

	1st	2nd	3rd
a. Soldier tied casualty's together at waist			
b. Soldier allowed conscious casualty to clasp his hands around soldier's neck			
c. Soldier straddled casualty in a kneeling face-to-face position			
d. Soldier looped casualty's hands around his neck			
e. Soldier crawled and looked forward dragging the casualty with him			
f. Soldier protected the unconscious casualty's head from ground			

Instructor Comments:

Two Man Fore and Aft Carry

Soldiers Name: _____ SSN: _____ CO: _____ TM: _____
 Start: _____ Stop: _____ Initial Evaluator: _____
 Start: _____ Stop: _____ Retest Evaluator: _____
 Start: _____ Stop: _____ Final Evaluator: _____

		1st	2nd	3rd
a.	First bearer (1) Casualty placed in a supine position (2) First bearer approached casualty from head and kneeled down on one knee and raised casualty to sitting position (3) Bearer one passed his hands under the casualty's arms and interlocked them in front of the casualty's chest	P / F	P / F	P / F
b.	Second bearer (1) Approached casualty from feet (2) Legs of the casualty spread apart (3) Second bearer executed an about face, kneeled to one knee (4) Bearer encircled the casualty's knees in his hands	P / F	P / F	P / F
c.	Bearers lifted casualty (1) Upon command "Lift", both bearers stood up (2) Bearers used reverse procedure to place casualty on the ground or litter.	P / F	P / F	P / F

Instructor Comments:

Four Hand Seat Carry

Soldiers Name: _____ SSN: _____ CO: _____ TM: _____
Start: _____ Stop: _____ Initial Evaluator: _____
Start: _____ Stop: _____ Retest Evaluator: _____
Start: _____ Stop: _____ Final Evaluator: _____

		1st	2nd	3rd
a.	Bearers (1) Considered four hand seat carry when hand or foot injuries were present (2) Assured casualty is conscious	P / F	P / F	P / F
b.	Bearer positioned (1) Each bearer grasped his left wrist with right hand (2) Bearers face each other (3) Bearers grasp each others wrist with left hand	P / F	P / F	P / F
c.	Bearers instructed casualty (1) Sit on seat formed by bearer's hands (2) Instructed to support himself by encircling bearer's shoulders (3) Bearers used the reverse procedure to place casualty on the ground or on a litter	P / F	P / F	P / F

Instructor Comments:

***Appendix D
Litter Evacuation
Competency Skill Sheets***

Litter Evacuation Procedures

Soldiers Name: _____ SSN: _____ CO: _____ TM: _____

Start: _____ Stop: _____ Initial Evaluator: _____

Start: _____ Stop: _____ Retest Evaluator: _____

Start: _____ Stop: _____ Final Evaluator: _____

		1st	2nd	3rd
a.	Soldier medic coordinated with platoon company headquarters regarding (1) Special equipment or personnel requirements (2) Verification of evacuation routs (3) Tactical situation in rout to the site and tactical situation on site (4) Location of possible collection points (5) Location of most critically wounded (6) Number and type pf casualties	P / F	P / F	P / F
b.	Soldier medic assisted in establishing a collection point (1) Secured site with driver and other available personnel (2) Parked vehicle facing enemy (doors to the rear) (3) Litter teams established and aid men assigned to teams or casualty sites (4) Casualties surveyed at initial site to establish evacuation priority	P / F	P / F	P / F
c.	Soldier medic assisted in operating the casualty collection point (1) Surveyed patients to determine further evacuation priority, and provided necessary treatment prior to evacuation (2) Identified casualties who have been contaminated (3) Ensured Field Medical Card is complete and attached (4) Loaded casualties into vehicle according to priority of treatment	P / F	P / F	P / F
d.	Soldier medic contacted commander or senior aidman and receiving aid station at time of departure and at stated ETA	P / F	P / F	P / F
e.	Moved with platoon along prescribed movement routs, taking advantage of cover and concealment	P / F	P / F	P / F
f.	Assisted medical platoon leader operational intelligence of the battle area provided by platoon	P / F	P / F	P / F

Instructor Comments:

Improvised Litters

Soldiers Name: _____ SSN: _____ CO: _____ TM: _____

Start: _____ Stop: _____ Initial Evaluator: _____

Start: _____ Stop: _____ Retest Evaluator: _____

Start: _____ Stop: _____ Final Evaluator: _____

	1st	2nd	3rd
<p>a. Soldier gathered and assembled materials to make an improvised pole and poncho litter</p> <p>(1) Soldier medic opened poncho fully</p> <p>(2) Spread poncho on the ground with hood and drawstring up</p> <p>(3) Laid one pole lengthwise across center, folded poncho over in half</p> <p>(4) Placed second pole at the center of the folded poncho</p> <p>(5) Folded free edges of poncho over second pole Casualty's weight locked the poncho in place</p>	P / F	P / F	P / F
<p>b. Soldier gathered and assembled materials to make an improvised pole and jacket litter</p> <p>(1) Buttoned or snapped all buttons and snap on two jackets or shirts</p> <p>(2) Turned the sleeves inside the body of the jackets</p> <p>(3) Buttoned the two jackets or shirts together at the lapels</p> <p>(4) Laid the jacket or shirt on the ground with the buttons or snaps toward the ground</p> <p>(5) Placed a litter pole through each sleeve, starting at the shoulder of one jacket, going all the way through to the end of the pole, then coming back through the other jacket sleeve</p>	P / F	P / F	P / F
<p>c. Soldier gathered and assembled materials to make a pole and sack litter</p> <p>(1) Soldier medic took the closed end of a sack and cut holes in the corner large enough to slide a litter pole through</p> <p>(2) Placed two sacks open end to open end flat on the ground</p> <p>(3) Placed two poles through the large openings starting at the center of one sack going all the way through to the end of the pole, then came back through the other sack</p> <p>(4) Soldier medic overlapped the two open ends of the sacks approximately 3 inches at the center of the litter</p>	P / F	P / F	P / F
<p>d. Soldier gathered and assembled materials to make a poncho litter without poles</p> <p>(1) Soldier medic spread a poncho flat on the ground or floor</p> <p>(2) Placed the casualty across the center of the poncho</p> <p>(3) Instructed bearers to roll tightly from both ends toward the casualty</p> <p>(4) Instructed bearers to place their hands as close to the casualty as possible and to support the head and neck when lifting.</p>	P / F	P / F	P / F

Instructor Comments:

Four Man Carry

Soldiers Name: _____ SSN: _____ CO: _____ TM: _____

Start: _____ Stop: _____ Initial Evaluator: _____

Start: _____ Stop: _____ Retest Evaluator: _____

Start: _____ Stop: _____ Final Evaluator: _____

	1st	2nd	3rd
a. Acting as team leader, the soldier medic positioned one bearer at each corner of the litter	P / F	P / F	P / F
b. Leader gave the commands "Prepare for lift, Lift" team members bent down placing the knee closest to the litter on the ground	P / F	P / F	P / F
c. Team members placed the hand closest to the litter on the handle	P / F	P / F	P / F
d. Team members placed their free hand on their up knee for support	P / F	P / F	P / F
e. Litter was raised in a smoothly on the command : "Lift"	P / F	P / F	P / F

Instructor Comments:

Litter Post Carry

Soldiers Name: _____ SSN: _____ CO: _____ TM: _____

Start: _____ Stop: _____ Initial Evaluator: _____

Start: _____ Stop: _____ Retest Evaluator: _____

Start: _____ Stop: _____ Final Evaluator: _____

	1st	2nd	3rd
a. Acting as team leader soldier medic commands, "Litter-post, carry, move!"	P / F	P / F	P / F
b. One designated member of the bearer team at each end of the litter grasp both handles	P / F	P / F	P / F
c. Freed member from each end of the litter moves to the center of the pole on each side of the casualty facing each other and grasp the pole.	P / F	P / F	P / F
d. Team leader commanded "Prepare to rotate, Rotate"	P / F	P / F	P / F
e. Bearers at the ends of the litter released the litter	P / F	P / F	P / F
f. Members on the sides of the litter rotated 180 ⁰ counter clockwise	P / F	P / F	P / F
g. Once litter was rotated members at the end of the litter resumed their positions with both hands on the litter handles	P / F	P / F	P / F

Instructor Comments:

Uphill/Downhill Carry

Soldiers Name: _____ SSN: _____ CO: _____ TM: _____
 Start: _____ Stop: _____ Initial Evaluator: _____
 Start: _____ Stop: _____ Retest Evaluator: _____
 Start: _____ Stop: _____ Final Evaluator: _____

	1st	2nd	3rd
a. Soldier medic assembles four member bearer team for uphill (upstairs carry) (1) Acting as team leader soldier medic commands, „Uphill, carry, move!“ (2) One designated member of the bearer team proceeded the litter (3) One designated member of the bearer team was designated to carry the front of the litter (4) The other team members were designated to carry the rear of the letter, one on each handle			
b. Soldier medic assembles four member bearer team for downhill (downstairs carry) (1) Acting as team leader soldier medic commands, „Downhill, carry, move!“ (2) One designated member of the bearer team at the head of the casualty grasp both handles (3) Two designated member of the bearer team at the feet of the casualty grasp the handles with both hands (4) The team leader proceeded the team and braced the two bearers at the foot of the litter			

Instructor Comments:

Low Crawl

Soldiers Name: _____ SSN: _____ CO: _____ TM: _____
Start: _____ Stop: _____ Initial Evaluator: _____
Start: _____ Stop: _____ Retest Evaluator: _____
Start: _____ Stop: _____ Final Evaluator: _____

	1st	2nd	3rd
a. Acting as team leader soldier medic commands, "Low crawl, move!"	P / F	P / F	P / F
b. Team members at each end of the litter moved to their knees and elbows	P / F	P / F	P / F
c. Leader commands, "Ready, lift!"	P / F	P / F	P / F
d. In unison members raise litter and moved it forward 6 to 8 inches and then lowered it gently	P / F	P / F	P / F
e. Members crawled forward and repeated lift and lowering procedure	P / F	P / F	P / F
f. Members returned to their original positions on the command, "Prepare to lift, lift!"	P / F	P / F	P / F

Instructor Comments:

Overhead Carry

Soldiers Name: _____ SSN: _____ CO: _____ TM: _____
 Start: _____ Stop: _____ Initial Evaluator: _____
 Start: _____ Stop: _____ Retest Evaluator: _____
 Start: _____ Stop: _____ Final Evaluator: _____

		1st	2nd	3rd
a.	Soldier medic assembles four person bearer team			
(1)	Acting as team leader soldier medic commands, "Overhead, carry, move!"			
(2)	Leader instructed team members at each end of the litter to face each other across the litter			
(3)	Team leader determined who the taller member is at each end of the litter			
(4)	Leader instructed the taller member at each end to go between the litter handles and place their hands as close to the litter canvas as possible			
(5)	Leader instructed the shorter member at each end to move under the litter and grasp the litter poles between the stirrups and handles			
(6)	Leader insures all members are faced in the same direction			
b.	Soldier medic recovers four person bearer team			
(1)	Leader commands, "Four-man carry, move"			
(2)	Shorter individuals returned to their original handles			
(3)	Taller individuals returned to their original handles			
(4)	On the command of execution, the litter was lowered and kept level			

Instructor Comments:

Appendix E
Evacuation Platforms
Competency Skill Sheets

Ambulance Evacuation Platforms

Soldiers Name: _____ SSAN: _____ CO: _____ TM: _____

Start: _____ Stop: _____ Initial Evaluator: _____

Start: _____ Stop: _____ Retest Evaluator: _____

Start: _____ Stop: _____ Final Evaluator: _____

	1st	2nd	3rd
<p>a. Soldier medic assembles a four man bearer team</p> <p>(1) Acting as team leader soldier medic positioned one bearer at each corner of the litter</p> <p>(2) Leader gave the commands „Prepare to lift, Lift“ team members bent down placing the knee closest to the litter on the ground</p> <p>(3) Team members placed the hand closest to the litter on the handle</p> <p>(4) Team members placed their free hand on their up knee for support</p> <p>(5) Litter was raised smoothly on the command:“ Lift“</p>	P / F	P / F	P / F
<p>b. Soldier medic assured that casualty was moved carefully to ambulance</p> <p>(1) Unless nature of injury indicated otherwise, soldier medic assured that casualty was loaded head first</p> <p>(2) Casualties with wounds of the chest or abdomen, or receiving IV fluids were loaded on lower berths</p> <p>(3) Casualties with bulky splints were placed on lower berths if possible</p> <p>(4) Assured that the most seriously injured casualties are loaded last</p> <p>(5) For loading four casualties used the berth sequence upper right, lower right, upper left, and lower left</p> <p>(6) For unloading four casualties used reverse berth sequence lower left, upper left, lower right, and upper right</p>	P / F	P / F	P / F
<p>c. When M996 or M997 is used soldier medic assured that casualty was moved carefully to the platform</p> <p>(1) Soldier medic as team leader reviewed the two and four litter configurations for the M996 or M997</p> <p>(2) With the two-litter configuration of the M996 the soldier medic loaded the right berth and then the left</p>	P / F	P / F	P / F
<p>d. When M996 or M997 is used soldier medic assured litter rails were assembled</p> <p>(1) From the litter rail extension stowage compartment the latch was turned counter clockwise to open door</p> <p>(2) Securing straps were loosened and disconnected</p> <p>(3) Folded litter rail was removed form stowage compartment</p> <p>(4) Left and right rails were pulled apart allowing the legs to lie flat on the ground</p> <p>(5) Support braces were locked and straps adjusted as needed</p>	P / F	P / F	P / F
<p>e. Soldier medic ensured straps and equipment did not inhibit litter loading operations. Litters were loaded carefully to prevent further injury.</p> <p>(1) Both rails of litter rail extension were secured into slots on litter rack</p>	P / F	P / F	P / F

	<ul style="list-style-type: none"> (2) Litter placed safely on litter rail extension (3) Litter slid onto litter rack (4) Litter secured onto rail with front and rear litter handle straps 			
f.	<p>Soldier medic ensured straps and equipment did not inhibit litter unloading operations. Litters were unloaded carefully to prevent further injury.</p> <ul style="list-style-type: none"> (1) Released front and rear litter handle straps which secure litter to litter rack (2) Secured both rails of litter rail extension into slots on lower litter rack (3) Slid litter from lower rack onto litter rail extension (4) Bearer team lifted up and removed litter from litter rail extension (5) Litter rail extensions were folded and stowed away 	P / F	P / F	P / F
g.	<p>Soldier medic opened/closed seats to accommodate ambulatory casualties</p> <ul style="list-style-type: none"> (1) Ensured litters are in stored position (2) Pulled out and up on seat latch to remove latch from catch (3) Lifted seat back to open position and folded seat back support recesses between seat cushions (4) Ensured seat braces are fully extended and locked into position (5) When closing seats pressed lock buttons on seat braces and folded braces toward seat back (6) Folded seat back support outward and folded seat back into closed position (7) Ensured guide pins on seat back support engaged holes in seat base (8) Installed seat back to base with seat latch and secured with latch handle. 	P / F	P / F	P / F
h.	<p>When loading the four-litter configuration on the M997, used the loading sequence upper right, lower right, upper left, and lower left</p> <ul style="list-style-type: none"> (1) Assured the most seriously injured casualties are loaded last (2) Used the reverse sequence for unloading lower left, upper left lower right, and upper right (3) When only tow berths were used loaded on the upper and lower right side (4) Soldier medic did not unload previously loaded patients on subsequent stops to maintain most seriously injured sequence 	P / F	P / F	P / F
i.	<p>Soldier medic prepared upper litter rack</p> <ul style="list-style-type: none"> (1) Unhooked tension strap from footman loop on lower rack (2) Pulled out upper litter rack handle and supported weight of upper litter rack (3) Unhooked lower suspension strap hook from loop on upper litter rack and clipped suspension strap hook to eye (4) Released litter support latch stop and pushed latch in and lowered upper litter rack onto lower litter rack (5) Slid litter rack handle into upper litter rack 	P / F	P / F	P / F
j.	<p>Soldier medic leads loading/unloading on upper rack</p> <ul style="list-style-type: none"> (1) Assembled litter rail extension 	P / F	P / F	P / F

	<ul style="list-style-type: none"> (2) Secured both rails of litter extension into slots of upper litter rack (3) Placed litter on litter rail extension (4) Slid litter up rails until litter was clear of litter rail extension (5) Secured rear litter handles to upper litter rack with rear litter handle straps (6) Removed litter rail extensions from upper litter rack (7) Unhooked suspension straps hook from eye (8) Pulled out upper litter rack handle (9) Raised upper litter rack and pushed into support latch and secured with stop (10) Attached suspension strap hook to loop on upper litter rack (11) Secured front litter handles to litter rack with front litter handle straps (12) Hooked tension strap to footman loop on lower litter rack and adjusted strap (13) Slid litter rack handle into upper litter rack (14) When unloading, released front litter straps from litter handle (15) Unhooked tension strap from footman loop on lower rack (16) Pulled out upper litter rack handle and supported weight of upper litter rack (17) Unhooked rear suspension strap hook from the loop on the upper rack (18) Released litter support latch stop by pushing latch in and lowered upper litter rack onto lower rack (19) Slid litter rack handle into upper litter rack (20) Secured rails of litter rail extension into slots of upper litter rack (21) Released rear litter handle straps from litter handles (22) Slid litter down litter rail extension until litter was clear of upper litter rack (23) Lifted and removed litter from litter rail extension (24) Removed and stowed litter rail extension from upper rack 			
k.	<p>Soldier medic leads loading/unloading on lower rack</p> <ul style="list-style-type: none"> (1) Secured both rails of litter rail extension into slots on lower litter rack (2) Placed litter on litter rail extension (3) Slid litter on to lower litter rack (4) Secured litter to lower rack with front and rear litter handle straps (5) When unloading, released front and rear litter straps securing litter to rack (6) Secured both rails of litter rail extension into slots on lower rack (7) Slid litter from lower rack onto litter rail extension (8) Lifted up and removed litter form litter rail extension 	P / F	P / F	P / F

Instructor Comments:

Helicopter Evacuation Platform

Soldiers Name: _____ SSN: _____ CO: _____ TM: _____

Start: _____ Stop: _____ Initial Evaluator: _____

Start: _____ Stop: _____ Retest Evaluator: _____

Start: _____ Stop: _____ Final Evaluator: _____

	1st	2nd	3rd
<p>a. Soldier medic assembles a four man bearer team to load helicopter</p> <p>(1) Acting as team leader directed team members to present a low silhouette as possible when approaching the helicopter</p> <p>(2) Directed team members to stay clear of the rotors and not to smoke within 50 feet</p> <p>(3) Soldier medic waited for and followed signals from aircraft crew before advancing</p> <p>(4) Bearer team approached aircraft at a 45° angle from the front of the helicopter</p> <p>(5) If conditions permit the helicopter is approached from the downhill side</p> <p>(6) Litters were carried parallel to the ground</p>	P / F	P / F	P / F
<p>b. When loading a UH-60A Blackhawk</p> <p>(1) Directed the loading of up to six ambulatory patients on the litter support unit, three on each side and a seventh on the troop seat</p> <p>(2) Reviewed Patient configuration restraints for a UH-60A Medical Kit and UH-60A Medical Kit with internal rescue hoist</p> <p>(3) Most seriously injured patients were loaded last on the bottom</p> <p>(4) Patients anticipated to require in rout emergency care were placed onto one of the top pans to facilitate access</p> <p>(5) Patients in traction splints loaded last when time and situation permits</p>	P / F	P / F	P / F
<p>c. Loading upper litters</p> <p>(1) For ease of loading upper litter pan's end shaft was disengaged and pan was tilted (top pan does not tilt if loading six patients)</p> <p>(2) When loading four litters with a four person team, litters were loaded from top to bottom</p> <p>(3) When loading patients from one side with the carousel turned used the sequence upper right, upper left, lower right, and lower left</p> <p>(4) When loading from both sides of the aircraft used sequence upper and the lower</p> <p>(5) Litter support unit was turned 90° clockwise to receive litter patients</p> <p>(6) Bearers moved into semi-overhead carry, lifting litter just high enough for the litter stirrups of one end to slide into the pan</p> <p>(7) Bearers slide litter forward until stirrups on both ends are secure in the pan</p> <p>(8) Flight crew raised pan to upright position and secured straps, bearers depart for next patient</p> <p>(9) Second, third and fourth patients are loaded in the same manner, except bottom pans are not tilted</p> <p>(10) After loading all four patients the litter support unit was turned 90° clockwise and locked into flight position</p> <p>(11) If patients five and six are being loaded the restraint modification kit was installed. The last two litters were</p>	P / F	P / F	P / F

(12)	side loaded between the restraints, with the patient's head toward the front of the aircraft and secured			
(13)	Cargo doors closed for flight The aircraft was unloaded in the reverse order of loading			
d.	When loading a UH-1H/V Iroquois (1) Directed the loading of up to six litter or nine ambulatory patients (2) Litters were loaded lengthwise on up to three tiers (3) Reviewed normal configuration of three litter patients loaded crosswise and four ambulatory patients (4) Patients were loaded from the top tier down with the most seriously injured being loaded last (5) Litter patients receiving IVs were not placed on top tier and as low as possible in the litter rack (6) Patients with Hare traction splints with supports and footrests were loaded last and placed on the floor of the aircraft	P / F	P / F	P / F
e.	Loading and securing patients (1) When loading six litter patients with a four bearer team, helicopter was loaded from both sides and from top to bottom (2) When mixed loading three litters were loaded crosswise and four ambulatory soldiers were seated in side seats (3) When loading from the left, the bearer team moved to the side of the helicopter with the litter perpendicular to the cargo compartment (4) The bearer team moved into the litter post carry position (5) Bearers 1 and 3 give there litter handles to the crew members (6) Bearers 2 and 4 secure the foot of the litter (7) Ambulatory patients were loaded after all litter patients (8) The aircraft was unloaded in the reverse order of loading	P / F	P / F	P / F

Instructor Comments: