

TC 55-60-18

**TRAINING PROGRAM
FOR THE
KALMAR 53,000-POUND ROUGH
TERRAIN CONTAINER HANDLER
(RTCH)**

OCTOBER 2008

DISTRIBUTION RESTRICTION: Approved for public release; distribution is unlimited.

HEADQUARTERS, DEPARTMENT OF THE ARMY

**This publication is available at
Army Knowledge Online (www.us.army.mil)
and the General Dennis J. Reimer
Training and Doctrine Digital Library at
(www.train.army.mil)**

TRAINING PROGRAM FOR THE KALMAR 53,000-POUND ROUGH TERRAIN CONTAINER HANDLER (RTCH)

Contents

	Page
PREFACE	IV
Chapter 1. RISK MANAGEMENT	1-1
1-1. GENERAL	1-1
1-2. BACKGROUND	1-1
1-3. COMPOSITE RISK MANAGEMENT	1-1
1-4. COMPOSITE RISK MANAGEMENT PROCESS	1-1
1-5. DEFINITIONS	1-3
1-6. RISK MANAGEMENT APPROACH	1-4
1-7. RISK ASSESSMENT ELEMENTS	1-5
1-8. DECISION AID	1-8
1-9. RISK CONTROL ALTERNATIVES	1-8
1-10. SUPERVISION	1-9
1-11. PAYOFFS	1-9
Chapter 2. INSTRUCTIONAL AIDS	2-1
2-1. STUDENT REQUIREMENTS	2-1
2-2. INSTRUCTOR REQUIREMENTS	2-1
2-3. TRAINING FACILITIES	2-1
2-4. TRAINING AIDS AND DEVICES	2-2
Chapter 3. SAMPLE TRAINING SCHEDULE	3-1

	Page
Chapter 4. KALMAR ROUGH TERRAIN CONTAINER HANDLER TRAINING PROGRAM	4-1
4-1. INTRODUCTION	4-1
4-2. PURPOSE	4-2
4-3. TRANSPORTATION SCHOOL	4-2
4-4. DUTIES AND RESPONSIBILITIES	4-2
4-5. REQUIRED INSTRUCTIONAL AIDS	4-3
4-6. TRAINING UNIFORM AND EQUIPMENT	4-3
4-7. HAZARDOUS CONDITIONS AND CONTROL MEASURES	4-3
4-8. EMERGENCY MEDICAL PERSONNEL	4-3
4-9. SAFETY REMINDER	4-3
4-10. LICENSING AND QUALIFICATION/DOCUMENTATION	4-3
4-11. LESSON OUTLINE FOR THE COURSE	4-4
Chapter 5. LESSON OUTLINE FOR SAFETY PROCEDURES AND HAND AND ARM SIGNALS	5-1
5-1. LESSON TITLE: SAFETY PROCEDURES AND HAND AND ARM SAFETY	5-1
5-2. LESSON TITLE: MATERIAL HANDLING EQUIPMENT SAFETY SYMBOLS	5-3
5-3. LESSON TITLE: GROUND GUIDES FOR BACKING AND OPERATION OF MATERIAL HANDLING EQUIPMENT	5-10
Chapter 6. LESSON OUTLINE FOR THE KALMAR RT-240 ROUGH TERRAIN CONTAINER HANDLER FAMILIARIZATION AND PREVENTIVE MAINTENANCE CHECKS AND SERVICES	6-1
6-1. LESSON TITLE: KALMAR RT-240 ROUGH TERRAIN CONTAINER HANDLER FAMILIARIZATION AND PREVENTIVE MAINTENANCE CHECKS AND SERVICES	6-1
6-2. LESSON TITLE: CHARACTERISTICS AND CAPABILITIES	6-4
6-3. LESSON TITLE: GAUGES AND SWITCH PANEL CONTROLS	6-8
6-4. LESSON TITLE: OPERATOR CONTROLS AND INSTRUMENTS	6-14
6-5. LESSON TITLE: PREVENTIVE MAINTENANCE CHECKS AND SERVICES	6-27
6-5. LESSON TITLE: FAMILIAR WITH PREVENTIVE MAINTENANCE CHECKS AND SERVICES	6-29
6-7. LESSON TITLE: RELIEVING HYDRAULIC SYSTEM PRESSURE AND CAGING AND UNCAGING THE PARKING BRAKE	6-37
6-8. LESSON TITLE: LUBRICATION ORDER AND READING ON-BOARD COMPUTER	6-41
Chapter 7. LESSON OUTLINE FOR LIFTING AND TRANSPORTING CONTAINERS WITH THE KALMAR RT-240 ROUGH TERRAIN CONTAINER HANDLER	7-1
7-1. LESSON TITLE: LIFTING AND TRANSPORTING CONTAINERS	7-1
7-2. LESSON TITLE: FAMILIARIZATION WITH LIFTING AND TRANSPORTING CONTAINERS	7-3
7-3. LESSON TITLE: OFF-LOADING/STACKING CONTAINERS	7-9

	Page
Chapter 8. LESSON OUTLINE FOR OPERATIONS UNDER UNUSUAL CONDITIONS	8-1
8-1. LESSON TITLE: OPERATIONS UNDER UNUSUAL CONDITIONS	8-1
8-2. LESSON TITLE: LIFT AND TRANSPORT CONTAINERS UNDER UNUSUAL CONDITIONS.....	8-3
8-3. LESSON TITLE: INSTALL THE FORKLIFT KIT	8-10
8-4. LESSON TITLE: PREPARE THE KALMAR RT-240 ROUGH TERRAIN CONTAINER HANDLER FOR TRANSPORT	8-14
Chapter 9. END-OF-COURSE TEST	9-1
9-1. LESSON TITLE: END-OF-COURSE TEST.....	9-1
9-2. GENERAL INSTRUCTIONS BEFORE TESTING	9-5
9-3. DIRECTIONS FOR THE INSTRUCTOR	9-6
9-4. DIRECTIONS TO STUDENTS	9-7
9-5. DIRECTIONS FOR SCORING AND GRADING	9-8
9-6. SCORER INSTRUCTIONS FOR THE HANDS-ON PERFORMANCE TEST	9-8
9-7. MULTIPLE CHOICE PRACTICE WRITTEN TEST	9-9
9-8. TRAINING EVENT TIMES	9-14
9-9. PERFORMANCE TEST CHECKLISTS.....	9-15
APPENDIX A-SLIDES	A-1
APPENDIX B-FORCE PROTECTION ANNEX.....	B-1
APPENDIX C-60 RULES OF SAFETY FOR OPERATING MATERIAL HANDLING EQUIPMENT	C-1
APPENDIX D-PRACTICAL EXERCISES	D-1
APPENDIX E-HANDOUTS AND WORKSHEETS.....	E-1
Glossary.....	Glossary-1
References.....	References-1

Preface

This training circular (TC) provides a training program for the Kalmar 53,000-pound Rough Terrain Container Handler (RTCH) according to AR 600-55. It provides standardized training and testing in the operation, preventive maintenance, and safety of this vehicle. It stresses hands-on training with very little classroom instruction. It also does not include any theater-unique requirements. During the development of this TC, it was assumed that each driver candidate would have a state driver's license, have completed accident avoidance training according to TC 21-305, and possess an OF Form 346 (*U.S. Government Motor Vehicle Operator's Identification Card*) (stamped as a learner's permit).

The lesson content for this training program is arranged sequentially and separated into the following six chapters:

- Chapter 4 contains the lesson outline for Course Introduction and HAZCOM Safety.
- Chapter 5 contains Safety Procedures and Hand and Arm Signals.
- Chapter 6 contains training for the overall use and familiarization and PMCS of the Kalmar 53,000-pound RT-240 RTCH.
- Chapter 7 contains training for the Kalmar 53,000-pound RT-240 RTCH (with container).
- Chapter 8 contains training for the Kalmar 53,000-pound RT-240 RTCH (operation under unusual conditions).
- Chapter 9 contains the End-of-Course Test (Practice Written Test and Performance Test).

This TC also includes the following appendixes:

- Appendix A (Slides).
- Appendix B (Force Protection Annex).
- Appendix C (60 Rules of Safety for Operating Material Handling Equipment [MHE]).
- Appendix D (Practical Exercises).
- Appendix E (Handouts and Worksheets).

All training should be annotated on DA Form 348 (*Equipment Operator's Qualification Record (Except Aircraft)*) or ULLS-generated DA Form 348-E (*Operator Qualification Record*) according to AR 600-55.

This program may be used for initial and sustainment training. When used for sustainment training, commanders have the flexibility to choose and arrange training material based on the unit's mission, driver behavior, and/or accident history.

To provide effective training, each instructor should ensure his/her operators are trained and tested to the standards in this TC. Any deviation from the successful completion of these basic standards will only lessen the Soldiers overall driving effectiveness.

Graduates of this training program (licensed drivers) should be supervised until they have gained the experience to safely operate the Kalmar 53,000-pound RT-240 RTCH. Drivers should not be placed in situations that may be above their skill level. The supervisor should periodically monitor each driver to observe safe operating procedures and to determine the need for additional training.

The proponent of this publication is Headquarters (HQ) Training and Doctrine Command (TRADOC). This publication applies to the Active Army, the Army National Guard (ARNG)/Army National Guard of the United States (ARNGUS), and the United States Army Reserve (USAR) unless otherwise stated. Submit changes for improving this publication on DA Form 2028 (*Recommended Changes to Publications and Blank Forms*) and forward it to Commander, USACASCOM, Training Directorate, Transportation Division, ATTN: ATCL-TDM, Fort Lee, VA 23801-1511.

The US Army's environmental strategy into the 21st century defines the Army's leadership commitment and philosophy for meeting present and future environmental challenges. It provides a framework to ensure that environmental stewardship ethic governs all Army activities. The Army's environmental vision is to be a national leader in environmental and natural resource stewardship for present and future generations, as an integral part of all Army missions. The Army's environmental vision statement communicates the Army's commitment to the environment.

This page intentionally left blank.

CHAPTER 1

RISK MANAGEMENT

1-1. GENERAL. This chapter explains risk management as it applies to rough terrain container handler (RTCH) training. Refer to FM 5-0, Chapter 3, for more detailed risk management guidance.

1-2. BACKGROUND. Ground vehicle accidents cost the Army millions of dollars each year. These types of accidents also significantly reduce mission capabilities. Leaders must develop techniques that will save resources. Since the Army must be prepared to operate worldwide, the training mission has become increasingly demanding and so have the risks inherent in that mission. This increase in risk requires leaders to balance mission needs with hazards involved and make wise risk decisions.

1-3 COMPOSITE RISK MANAGEMENT. Composite Risk Management (CRM) is the Army's primary decision making process for identifying hazards and controlling risks across the full spectrum of Army missions, functions, operations, and activities.

a. A key element of risk decision making is determining what constitutes an acceptable level of risk. The primary premise of CRM is that it does not matter where or how the loss occurs, the result is the same — decreased combat power or mission effectiveness. However, risk or potential loss must be balanced against expectations or expected gains and risk decisions must always be made at the appropriate level of command or leadership and based on the level of risk involved.

b. The following are the guiding principles of CRM.

(1) Integrate CRM into all phases of missions or operational planning, preparation, execution, and recovery.

(2) Make risk decisions at the appropriate level. As a decision-making tool, CRM is only effective when the information is passed to the appropriate level of command for decision.

(3) Accept no unnecessary risk unless the potential gain or benefit outweighs the potential loss.

(4) Apply the process cyclically and continuously. CRM is applied continuously across the full spectrum of Army training and operations, individual and collective day-to-day activities and events, and base operations functions.

1-4. COMPOSITE RISK MANAGEMENT PROCESS. CRM is a five-step process. The steps are describes as follows:

a. Step 1 (Identify Hazards). A hazard is an actual or potential condition, situation, or event that can result in injury, illness, or death of personnel. A hazard can result in damage, loss, or destruction of equipment and property. It is also a situation or event that can result in degradation of capabilities or mission failure. Hazards exist in combat operations, stability operations, base support operations, training, garrison activities, and off-duty activities. Hazards can be associated with enemy activity, accident potential, weather or environmental conditions, health, sanitation, behavior, and/or material or equipment.

b. Step 2 (Assess Hazards to Determine Risk). Hazards and associated risks are assessed during the mission analysis, course of action (COA) development, and COA analysis steps of the military decision making process (MDMP). This assessment must consider impact on mission and non-mission related aspects of the operation. The end result of this assessment is an initial estimate of risk for each identified hazard expressed in terms of extremely high, high, moderate, or low. The following are the three sub-steps in this step:

- (1) Assess the probability of the event or occurrence.
- (2) Estimate the expected result or severity of an event or occurrence.
- (3) Determine specified level of risk for a given probability and severity using the standard risk assessment matrix (see Figure 1-1).

RISK ASSESSMENT MATRIX						
		Probability				
Severity		Frequent A	Likely B	Occasional C	Seldom D	Unlikely E
Catastrophic	I	E	E	H	H	M
Critical	II	E	H	H	M	L
Marginal	III	H	M	M	L	L
Negligible	IV	M	L	L	L	L
		E – Extremely High	H – High	M – Moderate	L – Low	

Figure 1-1. Risk Assessment Matrix

c. Step 3 (Develop Controls and Make Risk Decisions). This step is accomplished during the COA development, COA analysis, COA comparison, and COA approval stages of the MDMP. Controls can take many forms, but normally fall into one of the three following basic categories:

(1) Educational (awareness) controls. These controls are based on the knowledge and skills of organizations, units, or individuals. They include the awareness of the hazard and control. Effective educational control is implemented through individual and collective training that ensures performance to standard.

(2) Physical controls. These controls are barriers, guards, or signs to warn individuals, organizations, or units that a hazard exists. Special controller or oversight personnel also fall into this category.

(3) Avoidance/elimination controls. These controls include positive action to prevent contact with an identified hazard or the total elimination of the hazard. Sources such as personal experience, accident data from the Risk Management Information System, after-action reviews, and lessons learned from similar past operations can identify possible control measures for specific events, operations, or missions.

Note. The key to effective control measures is that they reduce or eliminate the identified hazard. Effective control measures must specify who, what, where, when, why, and how.

d. Step 4 (Implement Controls). Leaders and staffs ensure controls are integrated into standing operating procedures (SOPs), written and verbal orders, mission briefings, and staff estimates. The critical check for this step is to ensure controls are converted into clear and simple execution orders. Implementing controls includes coordination and communication with the following:

(1) Appropriate senior, adjacent, and subordinate units, organizations, and individuals.

(2) Logistics capability organizations and civilian agencies that are part of the force or may be impacted by the activity, hazard, or its control.

(3) The media, non-governmental organizations, and private volunteer organizations when their presence impacts or is impacted by the force. Leaders must explain how the controls will be implemented. Examples include the following:

- Overlays and graphics.
- Drills for vehicle and aircraft identification.
- Rehearsals and battle drills.
- Refresher training on threat and friendly vehicle identification for anti-armor and air defense weapons crews.
- Orientation for replacement personnel.
- Installation and maintenance of communications links for key civilian organizations.
- Operating convoys with a prescribed minimum number of vehicles.
- Provision to carry weapons and wear body armor and helmets when outside secure compounds.
- Accident awareness, safety briefings, and warnings.

e. Step 5 (Supervise and Evaluate). Leaders and staffs ensure risk controls are implemented and enforced to standard and provide the means of validating the adequacy of the selected control measures in supporting objectives and desired outcomes. Like other steps of the CRM process, supervision and evaluation must occur throughout all phases of any operation or activity. This continuous process provides the ability to identify weaknesses and to make changes or adjustments to controls based on performance, changing situations, conditions, or events.

1-5. DEFINITIONS.

a. Risk Management Process. Risk management is the process of identifying and controlling hazards to protect the force. It is a step-by-step process that provides a framework for analyzing any mission or task. The following are the five steps of risk management:

(1) Step 1 – Identify Hazards. Identify hazards to the force. Consider all aspects of current and future situation, environment, and known historical problem areas.

(2) Step 2 – Assess Hazards. Assess hazards to determine risks. Assess the impact of each hazard in terms of potential loss and cost based on probability and severity.

(3) Step 3 – Develop Controls and Make Risk Decision. Develop control measures that eliminate the hazards or reduce its risk. As control measures are developed, risks are reevaluated until all risks are reduced to a level where benefits outweigh potential cost.

(4) Step 4 – Implement Controls. Put controls in place that eliminates the hazards or reduce their risk.

(5) Step 5 – Supervise and Evaluate. Enforce standards and controls. Evaluate the effectiveness of control and adjust/update as necessary.

b. Hazard. A hazard is any real or potential condition that can cause injury, illness, or death of personnel or damage to or loss of equipment or property.

c. Risk. Risk is the chance of hazard or bad consequences or exposure to chance of injury or loss. Risk level is expressed in terms of hazard probability and severity.

d. Exposure. This is the frequency and length of time subjected to a hazard.

e. Probability. This is the likelihood that an event will occur.

f. Severity. This is the expected consequence of an event in terms of degree of injury, property damage, or other mission impairing factors (loss of combat power, adverse publicity, and so forth) that could occur.

g. Controls. Controls are actions taken to eliminate hazards or reduce their risk.

h. Risk Assessment. Risk assessment is the identification and assessment of hazards (first two steps of risk management process).

i. Residual Risk. The level of risk remaining after controls have been identified and selected for hazards that may result in loss of combat power. Controls are identified and selected until residual risk is at an acceptable level or until it cannot be practically reduced further.

j. Risk Decision. The decision to accept or not accept the risk(s) associated with an action.

1-6. RISK MANAGEMENT APPROACH. The following is the approach used in the risk management process.

a. Identify Hazards. Look for hazards in each phase of the training or operation.

b. Assess the Risk. Ask the following questions:

(1) What type of injury or equipment damage can be expected?

(2) What is the probability of an accident happening?

Note. A low probability of an accident and an expected minor injury equals low risk. A high probability of an accident and an expected fatality equals extremely high risk.

c. Develop Risk Control Alternatives and Make Risk Decisions. If you cannot eliminate the risk, then you must control it without sacrificing essential mission requirements. You can control some risks by

modifying tasks, changing location, increasing supervision, wearing protective clothing, changing time of operation, and so on. Decisions take several forms.

- (1) Selecting from available controls.
- (2) Modifying the mission because the risk is too great.
- (3) Accepting risk because mission benefits outweigh potential loss.

d. **Implement Risk Control Measures.** You must integrate procedures to control risks into plans, orders, SOPs, and training. You must also ensure risk reduction measures are used during actual operations.

e. **Supervise the Operations.** Make sure leaders know what controls are in place, what standards are expected, and then hold those in charge, accountable for implementation. This is the point when accident prevention actually happens.

1-7. RISK ASSESSMENT ELEMENTS. There are no hard and fast rules for assessing risk. Different training tasks involve different elements that can affect training safety. However, the following seven elements are central to safely completing most driver training tasks:

- Soldier qualification.
- Vehicle type.
- Weather.
- Terrain.
- Supervision.
- Equipment.
- Time of day.

Using matrixes that assign a risk level to each of the elements is one way to quickly appreciate the overall risks. The following matrixes (Table 1-1 through Table 1-7) are examples of risk assessments for the seven elements common to driver training missions.

Note. The factors are arbitrarily weighted. Modify them based on your particular mission and unit.

a. **Soldier Qualification Risk Value.** Measure Soldier qualification risk value (see Table 1-1) by comparing the level of task difficulty to the Soldier's military driving experience.

Table 1-1. Soldier Qualification Risk Value

SOLDIER QUALIFICATION RISK VALUE							
TASK	DRIVING EXPERIENCE						
	LICENSED OVER 1 YEAR			LICENSED UNDER 1 YEAR			UNLICENSED
COMPLEX		Moderate			High		High
ROUTINE		Low			Moderate		High
SIMPLE		Low			Low		Moderate

EXAMPLE: Unlicensed drivers learning lifting procedures on the RTCH would be a high risk situation requiring instructor supervision.

b. Vehicle Type Risk Value. Measure vehicle type risk value (see Table 1-2) by comparing the vehicle configuration to the locations of the training tasks.

Table 1-2. Vehicle Type Risk Value

VEHICLE TYPE RISK VALUE					
LOCATION OF TRAINING	VEHICLE CONFIGURATION				
	RTCH with FORKS			RTCH with TOPHANDLERS	
MOTOR POOL		Low			Low
ROAD		High			High
TRAINING AREA		Low			High

EXAMPLE: Driving a RTCH over the road would have a high risk value.

c. Weather Risk Value. Measure weather risk value (see Table 1-3) by comparing the road conditions with visibility.

Table 1-3. Weather Risk Value

WEATHER RISK VALUE							
ROAD CONDITIONS	VISIBILITY						
	CLEAR			REDUCED		RESTRICTED	
ADEQUATE		Moderate			Moderate		High
FAVORABLE		Moderate			Moderate		High
UNFAVORABLE		High			High		High

EXAMPLE: Driving on icy roads in fog would have a high risk value.

d. Terrain Risk Value. Measure terrain risk value (see Table 1-4) by comparing the physical features of the land with the existing road network.

Table 1-4. Terrain Risk Value

TERRAIN RISK VALUE							
TYPE OF TERRAIN	ROAD NETWORK						
	IMPROVED ROADS		SECONDARY ROADS			UNIMPROVED	
MOUNTAIN		High			High		High
DESERT/JUNGLE		Moderate			Moderate		High
FLAT/ROLLING		Low			Low		Moderate

EXAMPLE: Driver training conducted at Fort Bragg, NC, over trails would have a moderate risk value.

e. Supervision Risk Value. Measure supervision risk value (see Table 1-5) by comparing the level of supervision to the task location.

Table 1-5. Supervision Risk Value

SUPERVISION RISK VALUE			
LEVEL OF SUPERVISION	TASK LOCATION		
	MOTOR POOL	TRAINING AREA/ NONCONGESTED ROAD	OFF ROAD/ CONGESTED ROAD
NOT OBSERVING	High	High	High
OBSERVING	Low	Moderate	High
IN VEHICLE	Low	Low	Moderate

EXAMPLE: A student driving alone, but observed, in a training area would have a moderate risk value.

f. Equipment Risk Value. Measure equipment risk value (see Table 1-6) by comparing the equipment's age to the time (months) since the last semiannual service. Equipment age is defined as follows:

- Old is 15 years old or more.
- Average is 5 to 15 years old.
- New is 5 years old or less.

Table 1-6. Equipment Risk Value

EQUIPMENT RISK VALUE						
EQUIPMENT AGE	LAST SEMIANNUAL SERVICE					
	0 TO 2 MONTHS		+ 2 TO 4 MONTHS			+ 4 MONTHS
OLD		Moderate			Moderate	High
AVERAGE		Low			Moderate	High
NEW		Low			Low	Moderate

EXAMPLE: An eight-year-old RTCH serviced 3 months ago would have a moderate risk value.

g. Time of Day Risk Value. Measure the time of day risk value (see Table 1-7) by comparing the level of light to familiarity with the route.

Table 1-7. Time of Day Risk Value

TIME OF DAY RISK VALUE							
ROUTE FAMILIARITY	LIGHT LEVEL						
	DAY			DAWN/DUSK		NIGHT	
NEVER DRIVEN ROUTE		Moderate			High		High
DRIVEN ROUTE 1 TO 3 TIMES		Moderate			High		High
FAMILIAR ROUTE		Low			High		High

EXAMPLE: A driving task over a familiar route that starts during the day but ends at dusk would have a high risk value.

After assessing all the risks, the overall risk value equals the highest risk identified for any one element. Now is the time to focus on high risk elements and develop controls to reduce risks to an acceptable level. Control examples may include conducting training in a different location or at a different time of day, putting an instructor in the vehicle with the student, waiting for better weather, using a different vehicle, and so on.

1-8. DECISION AID. The level of the decision maker should correspond to the level of the risk. The greater the risk, the more senior the final decision maker should be. The matrix shown in Table 1-8 is a proposed decision aid to help determine the leadership decision-making level.

Table 1-8. Proposed Decision Aid

DECISION AID	
RISK	DECISION LEVEL
LOW	SENIOR INSTRUCTOR
MODERATE	COMPANY COMMANDER
HIGH	BATTALION COMMANDER

a. Moderate risk training warrants complete unit command involvement. For example, a moderate risk value in the weather element category indicates that Soldiers are more susceptible to cold injuries and require closer supervision or a rescheduling of training. If you cannot reduce the risk level, the company commander should decide to train or defer the mission.

b. Operations with a high-risk value warrant battalion involvement. If you cannot reduce the risk level, the battalion commander should decide to train or defer the mission.

1-9. RISK CONTROL ALTERNATIVES. The following options can help control risk:

- Eliminate the hazard totally, if possible, or substitute a less hazardous alternative.
- Reduce the magnitude of the hazard by changing tasks, locations, times, and so forth.
- Modify operational procedures to reduce risk exposure consistent with mission needs.
- Train and motivate personnel to perform to standards to avoid hazards.

1-10. SUPERVISION. Leaders must monitor the training to ensure risk control measures are followed. Never underestimate a subordinate's ability to sidetrack a decision they do not understand or support. You must also monitor the impact of risk reduction procedures when they are implemented to see that they really work. This is especially true of new, untested procedures.

1-11. PAYOFFS. Risk management lets you use realistic training scenarios reducing personnel and equipment losses while training. Risk management is consistent with METT-T decision processes and can be used in battle to increase mission effectiveness.

SAMPLE RISK ASSESSMENT WORKSHEET FOR DRIVER TRAINING

TRAINING TASK: _____

RISK ASSESSMENT LEVEL: _____

_____ 1. SOLDIER QUALIFICATION

SOLDIER QUALIFICATION RISK VALUE						
TASK	DRIVING EXPERIENCE					
	LICENSED OVER 1 YEAR		LICENSED UNDER 1 YEAR		UNLICENSED	
COMPLEX		Moderate			High	
ROUTINE		Low			Moderate	
SIMPLE		Low			Low	
					High	
					High	
					Moderate	

_____ 2. VEHICLE TYPE

VEHICLE TYPE RISK VALUE						
LOCATION OF TRAINING	VEHICLE CONFIGURATION					
	RTCH without Tophandlers		RTCH with Tophandlers		RTCH with Forks	
ROAD		Moderate				Moderate
TRAINING		Low				Low
AREA MOTOR		Low				Low
POOL					High	
					Moderate	
					Low	

_____ 3. WEATHER

WEATHER RISK VALUE						
ROAD CONDITIONS	VISIBILITY					
	CLEAR		REDUCED		RESTRICTED	
UNFAVORABLE		Moderate				High
ADEQUATE		Low				High
FAVORABLE		Low				High
					High	
					Moderate	
					Moderate	

_____ 4. TERRAIN

TERRAIN RISK VALUE						
TYPE OF TERRAIN	ROAD NETWORK					
	IMPROVED ROADS		SECONDARY ROADS		UNIMPROVED	
MOUNTAIN		Moderate				High
DESERT/JUNGLE		Low				High
FLAT/ROLLING		Low				Moderate
					High	
					Moderate	
					Low	

_____ 5. SUPERVISION

SUPERVISION RISK VALUE								
LEVEL OF SUPERVISION	TASK LOCATION							
	MOTOR POOL			TRAINING AREA/ NONCONGESTED ROAD			OFF ROAD/ CONGESTED ROAD	
NOT OBSERVING IN VEHICLE		High Low Low			High Moderate Low			High High Moderate

_____ 6. EQUIPMENT

EQUIPMENT RISK VALUE								
EQUIPMENT AGE	LAST SEMIANNUAL SERVICE							
	0 TO 2 MONTHS			+ 2 TO 4 MONTHS			+ 4 MONTHS	
OLD AVERAGE NEW		Moderate Low Low			Moderate Moderate Low			High High Moderate

_____ 7. TIME OF DAY

TIME OF DAY RISK VALUE								
ROUTE FAMILIARITY	LIGHT LEVEL							
	DAY			DAWN/DUSK			NIGHT	
NEVER DRIVEN ROUTE DRIVEN ROUTE 1 TO 3 TIMES FAMILIAR ROUTE		Moderate Moderate Low			High High High			High High Moderate

_____ 8. OVERALL RISK LEVEL

DECISION AID	
RISK	DECISION LEVEL
LOW	SENIOR INSTRUCTOR
MODERATE	COMPANY COMMANDER
HIGH	BATTALION COMMANDER

APPROVED BY: _____ DATE: _____

This page intentionally left blank.

CHAPTER 2

INSTRUCTIONAL AIDS**2-1. STUDENT REQUIREMENTS.**

a. Forklifts Per Student. Forklift to student ratio is contained in the instructional material and varies from 1:2 to 1:6.

b. Forms Per Student.

(1) DA Form 348 (Equipment Operator's Qualification Record (Except Aircraft)).

(2) DA Form 2404 (Equipment Inspection and Maintenance Worksheet) or ULLS-generated DA Form 5988-E (Equipment Inspection Maintenance Worksheet).

(3) OF Form 346 (US Government Motor Vehicle Operator's Identification Card).

c. Publications Per Student. STP 55-88H14-SM-TG, TM 10-3930-675-10-1, TM 10-3930-675-10-2, LO 10-3930-675-12, and DA Pamphlet 750-8.

d. Nonstandard Items.

(1) Kalmar 53,000-pound RT-240 RTCH with tophandler that is adjustable from 20 feet to 40 feet.

(2) International Organization for Standardization (ISO) container, 20-foot and 40-foot.

(3) Leather gloves.

(4) Helmet/hard hat.

(5) Safety boots.

(6) Hearing protection.

2-2. INSTRUCTOR REQUIREMENTS.

- One each of the above forms.
- One each of the above publications.
- Student handouts.

2-3. TRAINING FACILITIES.

- Classroom.
- Motor pool.
- Training area(s).

2-4. TRAINING AIDS AND DEVICES.

- Overhead projector.
- Projection screen.
- Television.
- Videocassette player.
- Paper.
- Pen/pencil.
- Slides.

CHAPTER 3

SAMPLE TRAINING SCHEDULE

WHEN	WHAT	WHERE	PRODUCT CONTROL NUMBER
COURSE INTRODUCTION, HAZCOM SAFETY, AND VEHICLE FAMILIARIZATION			
DAY 1			
0800-0900	Course Introduction	Classroom	88RTCA01
0900-1000	HAZCOM Safety Briefing	Classroom	88RTCA02
1000-1100	Material Handling Equipment (MHE) Safety Symbols	Classroom	88RTCB01
1100-1130	Ground Guides Procedures for Backing MHE	Training Area	88RTCB02
1130-1230	Lunch		
1230-1300	Ground Guides Procedures for Backing (MHE)	Training Area	88RTCB02
1300-1700	Introduction to Kalmar RTCH and Familiarization	Classroom	88RTCC01
VEHICLE FAMILIARIZATION			
DAY 2			
0800-1130	Introduction to Kalmar RTCH and Familiarization	Classroom	88RTCC01
1130-1230	Lunch		
1230-1600	Introduction to Kalmar RTCH and Familiarization	Classroom/ Training Area	88RTCC01
1600-1700	Preventive Maintenance Checks and Services (PMCS)	Classroom	88RTCC02
VEHICLE FAMILIARIZATION			
DAY 3			
0800-1130	Preventive Maintenance Checks and Services (PMCS)	Classroom/ Training Area	88RTCC02
1130-1230	Lunch		
1230-1700	Preventive Maintenance Checks and Services (PMCS)	Classroom/ Training Area	88RTCC02

WHEN	WHAT	WHERE	PRODUCT CONTROL NUMBER
VEHICLE FAMILIARIZATION			
DAY 4			
0800-1130	Kalmar RT-240 V2 Update	Classroom/ Training Area	88RTCC03
1130-1230	Lunch		
1230-1300	Kalmar RT-240 V2 Update	Training Area	88RTCC03
1300-1700	Lifting and Transporting Containers	Classroom/ Training Area	88RTCD01
VEHICLE FAMILIARIZATION			
DAY 5			
0800-1130	Lifting and Transporting Containers	Training Area	88RTCD01
1130-1230	Lunch		
1230-1700	Lifting and Transporting Containers	Training Area	88RTCD01
VEHICLE FAMILIARIZATION			
DAY 6			
0800-1130	Lifting and Transporting Containers	Training Area	88RTCD01
1130-1230	Lunch		
1230-1700	Lifting and Transporting Containers	Training Area	88RTCD01
VEHICLE FAMILIARIZATION			
DAY 7			
0800-1130	Lifting and Transporting Containers	Training Area	88RTCD01
1130-1230	Lunch		
1230-1700	Lifting and Transporting Containers	Training Area	88RTCD01
VEHICLE FAMILIARIZATION			
DAY 8			
0800-1130	Lifting and Transporting Containers	Training Area	88RTCD01
1130-1230	Lunch		
1230-1500	Lifting and Transporting Containers	Training Area	88RTCD01
1500-1700	Operating Under Unusual Conditions	Classroom	88RTCE01

WHEN	WHAT	WHERE	PRODUCT CONTROL NUMBER
VEHICLE FAMILIARIZATION			
DAY 9			
0800-1130	Operating Under Unusual Conditions	Classroom/ Training Area	88RTCE01
1130-1230	Lunch		
1230-1700	Operating Under Unusual Conditions	Training Area	88RTCE01
VEHICLE FAMILIARIZATION			
DAY 10			
0800-1000	Operating Under Unusual Conditions	Training Area	88RTCE01
END-OF-COURSE TESTING			
1000-1130	End-of-Course Written Examination	Classroom	88RTCF01
1130-1230	Lunch		
1230-1300	End-of-Course Written Examination	Classroom	88RTCF01
1300-1700	End-of-Course Test	Training Area	All Tasks

This page intentionally left blank.

CHAPTER 4

KALMAR ROUGH TERRAIN CONTAINER HANDLER TRAINING PROGRAM

4-1. INTRODUCTION. This chapter is structured as a model to provide familiarization training on the Kalmar Rough Terrain Container Handler (RTCH) in various locations. The Kalmar RT-240 RTCH was designed for military and commercial applications. It has the ability to travel over unimproved rough terrain surfaces while easily handling twenty or forty foot containers. It also has the ability to distribute materials required to support wartime operations requirements in Iraq and Afghanistan. The Kalmar RT-240 RTCH has a carrying capacity of up to 53,000 pounds. It can move ISO containers stacked up to three containers high (see Figure 4-1). This end item can be very complex and expensive. It costs approximately \$500,000 each and weighs 117,000 pounds. The military forces can transport the Kalmar RT-240 by ground, air, and sea. The operators can move the operator's cab to one side and lower it. The RTCH boom can then be folded into position next to the cab. According to the Kalmar Rough Terrain Center (KRTC), once completely collapsed, the total height of the container handler is 118 inches. This enables it to be transported in a C-5 or C-17 aircraft.



Figure 4-1. ISO Containers Stacked Up to Three Containers High

4-2. PURPOSE. The purpose for the RTCH Mobile Training Team (MTT) is to provide relative off-site functional operator training to various units prior to deployment and those units deployed. The RTCH is a pacing item for the Seaport Operations Companies, Inland Cargo Transfer Companies, Heavy Lift Platoons, and Quartermaster Supply Companies. The RTCH operates worldwide on multiple terrains to include sand. The biggest problem facing the operation of the Kalmar RT-240 RTCH is the fact that there is a shortage of trained operators. Coupled with that fact, many of the RTCH's came out of the Army prepositioned stock into the area of responsibility (AOR) and Soldiers fell in on them not being certified to operate or maintain the Kalmar RTCH.

4-3. TRANSPORTATION SCHOOL. The challenges facing the Transportation School at Fort Eustis, VA are to identify units ready to deploy which will be operating and maintaining the Kalmar RTCH. Some units have identified themselves and have coordinated with the Product Manager (PM), Container and Materials Handling Equipment (C/MHE) to receive training for their Soldiers prior to deployment. However, Fort Eustis resident 80-hour functional training is currently being trained under the HQ TRADOC, DCSOPS&T, TOMA-P approved Program of Instruction (POI) in ATRRS = 500-ASIR1(42A/89B/92A). The Fort Eustis MTT will be providing non-resident Kalmar RTCH training outlined in the Course Administrative Data (CAD) approved by TRADOC, dated 6 November 2006 as 500-ASIR1 (CSS) (MTT-A).

4-4. DUTIES AND RESPONSIBILITIES. The following are the duties and responsibilities of the unit commander requesting and receiving the Kalmar RTCH training.

a. Commander. The commander must ensure adequate resources are allocated to support an effective on-site Mobile Training Team training program. The operations officer has staff responsibility, coordinating, fielding, and supervising the training team program while on-site, to include the following:

(1) Maintaining the currency and relevance of the RTCH standing operating procedures (SOPs).

(2) In concert with Command Safety Office and Directorate of Logistics (DOL), ensuring an inspection and maintenance program is conducted on the RTCH apparatus and facility.

(3) Ensuring users conduct pre-operation, during operation, and post-operation preventative maintenance and safety checks to ensure the RTCH is functioning properly.

(4) Coordinating procurement of additional training aids to support the RTCH training program as required.

(5) Overseeing the associated risk management process.

b. Safety Officer. The safety officer will—

(1) Assist with establishing and implementing the command's RTCH training, inspection, and safety programs.

(2) Review and monitor the MTT training program for safe operations.

(3) Review accident experience trends and provides an analysis to appropriate agencies/organizations as it pertains to the RTCH training.

(4) Assist in any investigation where a Soldier is injured while conducting RTCH training in order to mitigate the risk for future use.

c. Subordinate Commanders. Subordinate commanders will—

(1) Develop training plans in order to prepare Soldiers to conduct effective driving of the RTCH.

(2) Complete a risk assessment in accordance with Field Manual (FM) 5-19, prior to conducting RTCH training with their unit.

(3) Ensure personnel attending the RTCH training are medically fit to participate in this training. Commanders will screen Soldiers prior to RTCH training for any profiles or medical conditions that may preclude participation in the training.

(4) Notify those in their charge of the hazards associated with RTCH training.

(5) Ensure personnel attending RTCH training are properly equipped, including protective eyewear.

4-5. REQUIRED INSTRUCTIONAL AIDS. All required instructional aids are supplied by the MTT.

4-6. TRAINING UNIFORM AND EQUIPMENT. RTCH trainees will report wearing boots, Army combat uniform/desert combat uniform if deployed, protective eye wear (mandatory), hearing protection, helmet, body armor, personal and any crew-served weapon(s), protective masks (as required by the unit) load-bearing equipment/vest (LBE/V), and any other equipment that would typically be worn while riding in an Kalmar RTCH in a combat zone.

4-7. HAZARDOUS CONDITIONS AND CONTROL MEASURES. RTCH trainees must be informed of any known hazardous conditions and control measures that exist in the training environment. Trainees must remove all watches and rings, any jewelry worn around the neck, and empty all pockets of pens, pencils, and pocket knives. Trainees should not bring pagers or cell phones into the training area. Trainees must be briefed of their responsibility to report any unsafe/unhealthy condition they may discover. The instructor will identify the location of emergency equipment, fire exits, and procedures to be used in the event of a fire, injury, or other emergency. In the event of an RTCH emergency, signaled by three blasts on the whistle or sounding of applicable alarm, trainees should exit the RTCH immediately and proceed to the pre-designated location. A single long blast means trainees should remain inside the RTCH and not open the doors.

4-8. EMERGENCY MEDICAL PERSONNEL. There will be a minimum of one Combat Lifesaver (CLS) on site during any operation of the RTCH. Ideally, CLS services will be provided by the unit undergoing the training. Emergency medical personnel with appropriate equipment and a suitable vehicle for transport will be readily available during all RTCH operations training. The absence of any criteria in this paragraph requires a reassessment of the risk and the approval of the appropriate authority.

4-9. SAFETY REMINDER. All personnel will be reminded that equipment damage, personal injury, and even death can result from carelessness, failure to comply with the approved procedure, or violations of warnings, cautions, and safety regulations.

4-10. LICENSING AND QUALIFICATION/DOCUMENTATION. Commanders will ensure adequate records of initial training and annual revalidation are maintained for each trainee on the DA Form 348 (Equipment Operator's Qualification Record (Except Aircraft)) or service equivalent.

a. The RTCH will only be operated by instructor trainers certified in accordance with this TC. Selection of operators will be based on Appendix F in AR 600-55 (The Army Driver and Operator Standardization Program (Selection, Training, Testing, and Licensing)) and/or other applicable prescribing service directives.

b. A statement of qualification to operate the RTCH will be made on the DD Form 1902 (Certificate of Qualification) to show "RTCH Instructor/Operator Qualified."

4-11. LESSON OUTLINE FOR THE COURSE.

LESSON TITLE: COURSE INTRODUCTION

MOTIVATOR: Using personal experience or related story, explain why this lesson is important to the students.

TERMINAL LEARNING OBJECTIVE: At the completion of this lesson you will:

Action: After this lesson, the student will demonstrate knowledge of information required for successful participation in the course.

Condition: Given TM 10-3930-675-10-1 and TM 10-3930-675-10-2, class notes, and check on learning questions.

Standard: To receive a "GO" for this lesson unit the student will correctly answer all check on learning questions.

SAFETY REQUIREMENTS: Instructor will conduct Safety Briefing before operations begin each morning and maintain direct supervision throughout the day. Safety will be discussed and practiced throughout this lesson. Safety clothing (hard hats, gloves, steel toed boots, and hearing protection) will be worn at all times while performing Kalmar RT-240 RTCH operations tasks.

ENVIRONMENTAL CONSIDERATIONS: It is the responsibility of all Soldiers and DA civilians to protect the environment from damage. AR 200-1 delineates TRADOC responsibilities to integrate environmental requirements across DOTMLPF and ensure all training procedures, training materials, and training doctrine, to include sound environmental practices and considerations. The Army's environmental standard is to be a national leader in environmental and natural resource stewardship for present and future generations. This training support package meets this standard.

EVALUATION: Inform the Soldiers how, when, and where performance of the TLO will be evaluated.

ADMINISTRATIVE INSTRUCTIONS:

Training Time: As scheduled.

Training Location: Scheduled Classroom and Field Training Sites.

Training Type: Conference and Practical Exercises.

Students: Scheduled Personnel.

Principal and assistant instructors required based on instructor to student ratio in the Program of Instruction (POI).

INSTRUCTOR GUIDANCE:

- Ensure facilities, equipment, and training materials are prepared prior to class start time.
- Must be thoroughly prepared by studying this lesson and identified reference material.

LESSONS TAUGHT DURING THE COURSE:

- HAZCOM SAFETY
- SAFETY PROCEDURES AND HAND AND ARM SIGNALS
- MATERIAL HANDLING EQUIPMENT (MHE) SAFETY SYMBOLS
- GROUND GUIDES FOR BACKING AND OPERATION OF MATERIAL HANDLING EQUIPMENT (MHE)
- KALMAR RT-240 RTCH FAMILIARIZATION AND PMCS
- CHARACTERISTICS AND CAPABILITIES
- GAUGES AND SWITCH PANEL CONTROLS
- OPERATOR CONTROLS AND INSTRUMENTS
- PREVENTIVE MAINTENANCE CHECKS AND SERVICES
- FAMILIAR WITH PREVENTIVE MAINTENANCE CHECKS AND SERVICES
- RELIEVING HYDRAULIC SYSTEM PRESSURE AND CAGING AND UNCAGING THE PARKING BRAKE
- LUBRICATION ORDER AND READING ON-BOARD COMPUTER
- LIFTING AND TRANSPORTING CONTAINERS
- FAMILIARIZATION WITH LIFTING AND TRANSPORTING CONTAINERS
- OFF-LOADING/STACKING CONTAINERS
- OPERATIONS UNDER UNUSUAL CONDITIONS

- LIFT AND TRANSPORT CONTAINERS UNDER UNUSUAL CONDITIONS
- INSTALL THE FORKLIFT KIT
- PREPARE THE KALMAR RT-240 RTCH FOR TRANSPORT
- END-OF-COURSE TESTING

Use the appropriate Slides (Appendix A) designated in the lessons, Force Protection Annex (Appendix B), 60 Rules of Safety for Operating Material Handling Equipment (MHE) (Appendix C), Practical Exercises (Appendix D), Handouts and Worksheets (Appendix E) needed to teach this class.

Inform students of the TLO requirements before teaching each lesson (this course is 2 weeks in length).

Ask check on learning questions throughout each lesson.

Pass out outline of presentation prior to class.

RISK ASSESSMENT LEVEL: Low.

ADDITIONAL COMMENTS AND INFORMATION: Recommended instructional time for the TLO and ELO A is 1 hour conference.

ENABLING LEARNING OBJECTIVE A:

Action: After this lesson, the student will be able to demonstrate a basic knowledge of the Kalmar 53,000-pound RT-240 RTCH.

Condition: Given classroom instruction, use of class notes, TM 10-3930-675-10-1, and TM 10-3930-675-10-2.

Standard: To receive a "GO" for this lesson unit the student will correctly answer all check on learning questions.

1. Learning Step/Activity 1. Introduction to Kalmar RT-240 RTCH Course.

a. Overview of 500-ASIR1 Course and Safety Requirements. The purpose is to train you on the safety procedures and the functional operations of the Kalmar RT-240 RTCH.

b. Safety and Safety Equipment.

(1) Safety is everyone's responsibility. You must be alert for unsafe actions or situations.

(2) Safety has priority over training.

(3) Safety is a team/class effort.

c. Required Safety Equipment.

(1) Safety shoes (steel toe only).

(2) Work gloves (not black cold weather leather gloves).

(3) Hard hat.

(4) Protective clothing (wet weather gear).

(5) Hearing protection.

d. Administrative Information.

(1) Class roster - name, rank, SSN, break area-smoking policy/area.

(2) Class commander responsibilities.

(3) Clean up duties.

(4) No food or drinks in classroom.

Check on Learning

Determine if the students have learned the material presented by soliciting student questions and explanations. Ask the students the following questions and correct student misunderstandings.

- Q. What is the approximate length of the Kalmar RTCH course?
A. 2 weeks.
- Q. What is the minimum test score a student can receive and stay in the course?
A. 75 percent.
- Q. Who should you contact first if you have an academic problem?
A. Primary instructor.
- Q. Safety is whose responsibility?
A. All members of the class.

REVIEW/SUMMARIZE: For the last hour we have covered an overview of the Kalmar RTCH course.

TESTING REQUIREMENTS: This lesson is not examinable.

FEEDBACK REQUIREMENT: Rapid, immediate feedback is essential to effective learning. Schedule and provide feedback on the evaluation and any information to help answer students' questions about the test. Provide remedial training as needed.

TRANSITION TO THE NEXT LESSON: The next lesson will be HAZCOM Safety. Read your syllabus for your reading and study assignment.

LESSON TITLE: HAZCOM SAFETY

INSTRUCTOR GUIDANCE:

- Ensure facilities, equipment, and training materials are prepared prior to class start time.
- Must be thoroughly prepared by studying this lesson and identified reference material.
- Inform students of the TLO requirements before teaching each lesson.
- Ask check on learning questions throughout each lesson.
- Pass out outline of presentation prior to class.

RISK ASSESSMENT LEVEL: Low.

ADDITIONAL COMMENTS AND INFORMATION: Recommended instructional time is 1 hour (0.5 Conference and 0.5, video tape or DVD).

INSTRUCTIONAL LEAD IN: Welcome the students to the Kalmar 53,000-pound Rough Terrain Container Handler (RTCH) - HAZCOM Safety block of instruction.

Section I. Introduction

MOTIVATOR: Provide a short motivation introduction to the lesson. It can be a discussion, short demonstration, or videotape designed to peak student's interest and to focus them on the material they are about to learn. It needs to clearly inform the students why they need to know the information/skill that is being covered and the consequences of poor or nonperformance. Identify the job or battlefield conditions that make learning the task essential to the Soldier.

TERMINAL LEARNING OBJECTIVE: At the completion of this lesson you will:

Action: After this lesson, the student will demonstrate their knowledge of Occupational Safety and Health Administration (OSHA) requirements for training of hazardous materials in the workplace and during the operation of the MHE.

Condition: Given classroom instruction, student handout, and a video tape or DVD.

Standard: To receive a "GO" for this lesson, the student must correctly answer all check on learning questions.

SAFETY REQUIREMENTS: Instructor will conduct HAZCOM Safety Briefing before operations begin each morning and maintain direct supervision throughout the day. Safety will be discussed and practiced throughout this lesson. Safety clothing (hard hats, gloves, steel-toed boots, and hearing protection) will be worn at all times while performing Kalmar RT-240 RTCH operations tasks.

ENVIRONMENTAL CONSIDERATIONS: It is the responsibility of all Soldiers and DA civilians to protect the environment from damage. AR 200-1 delineates TRADOC responsibilities to integrate environmental requirements across DOTMLPF and ensure all training procedures, training materials, and training doctrine, to include sound environmental practices and considerations. The Army's environmental standard is to be a national leader in environmental and natural resource stewardship for present and future generations. This training support package meets this standard.

EVALUATION: Inform the Soldiers how, when, and where performance of the TLO will be evaluated.

ENABLING LEARNING OBJECTIVE B**1. Learning Step/Activity 1. HAZCOM Safety Briefing.**

a. Hazardous Communication (HAZCOM). The HAZCOM standard was issued by the OSHA in 1983 and revised in 1987 (Executive Order 12196) and Code of Federal Regulation (CFR) 29 provides the authority of implementing this standard within the federal sector. The HAZCOM standard helps protect your right to work in a safe and healthful environment. It requires that you be informed about the hazardous material/chemical in your workplace and be trained to work safely with these materials.

b. Regulatory Basis for HAZCOM.

(1) CFR 29, Part 1910.1200, Hazard Communication Standard.

(2) CFR 29, Part 1960, Basic Program Elements for Federal Employee Occupational Safety and Health.

(3) Executive Order 12196, Occupational Safety and Health Program for Federal Employees.

(4) DODI 6050.5, DOD Hazard Communication (HAZCOM) Program.

(5) Army Regulation 600-8-104 (Military Personnel Information Management/Records).

c. Goals of the HAZCOM Standard.

(1) Reduce the incidents of injury and illness caused by hazardous chemicals in the workplace.

(2) Identify and evaluate chemical controls.

(3) Establish uniform requirements for communication information about chemical hazards to both management and workers.

d. Actions required by chemical manufactures and Importers.

(1) Conduct hazard determinations to identify hazards of and appropriate control measures for the chemical they produce or import.

(2) Label all containers of hazardous chemicals leaving the workplace to communicate the identity of the material, all appropriate hazard warnings, and the name and address of the responsible party.

(3) Obtain or prepare accurate and up-to-date Material Safety Data Sheet (MSDS) (see Figure 4-3) for each hazardous chemical material sold and provide a copy to every employer that purchases the chemical.

(4) Update new information to the MSDS within three months after becoming aware of such information.

M S D S

Section I – Supplier Information

Manufacturer's Information
Manufacturer's Name: MATHESON GAS PRODUCTS INC
Manufacturer's Address1: 30 SEAVIEW DR
Manufacturer's Address2: SECACUS, NJ 07096
Manufacturer's Country: US
General Information Telephone: 201-867-4100
Emergency Telephone: 201-867-4100/800-424-9300(CHEMTREC)
Emergency Telephone: 201-867-4100/800-424-9300(CHEMTREC)
MSDS Preparer's Name: UNKNOWN

Section II – Hazardous Ingredients

<p>Ingredient Name: HYDROGEN SULFIDE (SARA III) Ingredient CAS Number: 7783-06-4 Ingredient CAS Code: M RTECS Number: MX1225000 RTECS Code: M =WT: =WT Code: =Volume: =Volume Code: >WT: >WT Code: >Volume: >Volume Code: <WT: <WT Code: <Volume: <Volume Code: % Low WT: % Low WT Code: % High WT: % High WT Code:</p>	<p>% Text: 100.0 % Environmental Weight: Other REC Limits: NONE RECOMMENDED OSHA PEL: C, 20 PPM OSHA PEL Code: M OSHA STEL: OSHA STEL Code: ACGIH TLV: 10 PPM/15 STEL; 9394 ACGIH TLV Code: M ACGIH STEL: N/P ACGIH STEL Code: EPA Reporting Quantity: 100 LBS DOT Reporting Quantity: 100 LBS Ozone Depleting Chemical: N</p>
--	---

Section III – Physical/Chemical Characteristics

Health Hazards Acute & Chronic: TARGET ORGANS:EYE, SKIN, CNS, RESPIRATORY TRACT. ACUTE- INHALATION:IRRITANT, ASPHYXANT, TOXIC. MAY CAUSE COUGH, PARALYSIS, SLEEPINESS, HEADACHE, BLURRED VISION, HEMORRHAGE & DEATH. EYES/SKIN:IRRITANT . MAY CAUSE FROSTBITE. ORAL:UNLIKELY. LIQUID CAN CAUSE FROSTBITE. CHRONIC- BLURRED VISION, PARALYSIS, INSOMNIA, ANOREXIA

Signs & Symptoms of Overexposure:
EYES, SKIN & RESPIRATORY TRACT IRRITATION; PULMONARY EDEMA, COUGH, SALIVATION, MUCOUS DISCHARGE, BLURRED VISION, HEMORRHAGE, HEADACHE, DIZZINESS, WEAKNESS, NAUSEA, VOMITING, COMA, CARDIOPULMONARY ARRE ST, DEATH, BRAIN DAMAGE, HYPOTENSION, PAIN IN LEGS, SKIN REDNESS AND BLISTERS, EYE PAIN

Section IV – Fire & Explosion Data

GET MEDICAL ATTENTION IMMEDIATELY. EYE/SKIN:IMMEDIATELY FLUSH WITH WATER FOR AT LEAST 15 MINUTES. HOLD EYELIDS OPEN. IF FROSTBITE, WARM WATER (107F) IS PREFERRED. INHALED:REMOVE TO FRESH AIR & PROVIDE OXYGEN/CPR IF NEEDED. ORAL:UNLIKELY. IF ADVERSE EFFECTS OCCUR, TREAT SYMPTOMATICALLY & SUPPORTIVELY.

Fire Fighting Procedures:
MOVE CONTAINER FROM FIRE AREA IF POSSIBLE. STAY AWAY FROM STORAGE TANK ENDS. COOL CYLINDERS WITH WATER USING UNMANNED DEVICE UNTIL WELL AFTER FIRE IS OUT.

Unusual Fire or Explosion Hazard:
GAS IS HEAVIER THAN AIR AND CAN TRAVEL CONSIDERABLE DISTANCE TO A SOURCE OF IGNITION AND FLASH BACK. CYLINDER MAY EXPLODE IN HEAT OF FIRE.

Extinguishing Media:
LET BURN UNLESS LEAK CAN BE STOPPED IMMEDIATELY. FOR LARGER FIRES USE WATER SPRAY, FOG OR STANDARD FOAM.

Flash Point: **Flash Point Text:** NOT RELEVANT

Page 1

Figure 4-3. MSDS Information

<h1>MSDS</h1>	
<h2>Section V – Reactivity Data</h2>	
<p>Respiratory Protection: IF WORKING IN A CONFINED AREA OR FIGHTING FIRE, USE NIOSH-APPROVED SELF-CONTAINED BREATHING APPARATUS OR SUPPLIED AIR RESPIRATOR WITH FULL FACEPIECE, OPERATED IN POSITIVE PRESSURE MODE.</p> <p>Ventilation: MECHANICAL (GENERAL AND/OR LOCAL EXHAUST, EXPLOSION-PROOF) VENTILATION TO MAINTAIN EXPOSURE BELOW PLV.</p> <p>Protective Gloves: COLD INSULATING GLOVES</p> <p>Eye Protection: SPLASH-PROOF SAFETY GOGGLES</p>	
<h2>Section VI – Health Hazard Data</h2>	
<p>HCC: G2 NRC/State License Number: NOT RELEVANT Net Property Weight for Ammo: N/R Boiling Point: Boiling Point Text: -78F,-61C Melting/Freezing Point: Melting/Freezing Text: -123F,-86C Decomposition Point: Decomposition Text: UNKNOWN Vapor Pressure: 15200 @77F Vapor Density: 1.2 Percent Volatile Organic Content: Specific Gravity: 1.539 G/L @ 32F Volatile Organic Content Pounds per Gallon: pH: 4.5SAT</p>	<p>Volatile Organic Content Grams per Liter: Viscosity: N/R Evaporation Weight and Reference: NOT RELEVANT Solubility in Water: 2.9% @ 20C (68F) Appearance and Odor: COLORLESS, GAS OR LIQUID - WITH AN ODOR OF ROTTEN EGGS Percent Volatiles by Volume: N/R Corrosion Rate: UNKNOWN</p>
<h2>Section VII – Handling and Use Precautions</h2>	
<p>Stability Indicator: NO Materials to Avoid: ACETALDEHYDE, COPPER, FLUORINE, METALS, METAL OXIDES, STRONG OXIDIZERS, POTASSIUM HYDROXIDE, SODA LIME, SODIUM HYDROXIDE Stability Condition to Avoid: HEAT, SPARKS, OTHER SOURCES OF IGNITION Hazardous Decomposition Products: TOXIC OXIDES OF SULFUR NOT RELEVANT</p>	
<h2>Section VIII – Control Measures</h2>	
<p>Waste Disposal Methods: DISPOSE OF IN ACCORDANCE WITH ALL FEDERAL, STATE AND LOCAL REGULATIONS. REPORTABLE QUANTITY (RQ) IS 100 POUNDS. IF THE RELEASE OF THIS SUBSTANCE IS REPORTABLE UNDER CERCLA SECTION 103, THE NATIONAL RESPONSE CENTER MUST BE NOTIFIED AT 800-424-8802. Product Identification: HYDROGEN SULFIDE (H2S) Transportation ID Number: 56789 Responsible Party CAGE: 0NPS5 Date MSDS Prepared: 03/29/1990 Date MSDS Reviewed: 09/28/1994 MFN: 09/28/1994 Submitter: D DG</p>	
Page 2	

Figure 4-3. MSDS Information (continued)

e. Actions Required by the Employer.

(1) Maintain an MSDS for every hazardous chemical used and make the MSDS available to workers on every shift.

(2) Make sure the containers of hazardous chemicals are labeled, tagged, or otherwise marked to identify the chemical and warn workers of the hazards it presents.

(3) Maintain an up-to-date list of all hazardous chemical materials known to be present in the workplace and make this list readily available to workers at all times.

(4) Inform and train workers.

(5) Maintain a written HAZCOM program that describes how the organization complies with the above actions and make this written program available upon request.

2. Learning Step/Activity 2. Show the HAZCOM video tape or DVD (The Federal Hazard Communication Training Program).

Note. Show the first two sections of the HAZCOM Safety video tape or DVD.

3. Learning Step/Activity 3. Physical Forms, Exposure Hazards, and Control Measures of Hazardous Materials.

a. Physical forms and exposure hazards.

b. Physical hazards. Chemicals that can cause explosions, fires, violent chemical reactions, or other hazardous situations.

c. Health hazards. Chemicals that can cause illness or injury when inhaled or swallowed or through contact with the skin or eyes.

d. The three basic forms of a chemical are SOLIDS, LIQUIDS, and GASES.

e. The following are the four ways that a chemical can enter the body:

(1) Breathing/inhalation.

(2) Skin/eye contact.

(3) Skin absorption.

(4) Swallowing/ingestion.

f. The degree of hazard associated with exposure to health hazards depends on the degree of toxicity.

(1) Low – Minor symptoms that go away when the exposure stops.

(2) Medium – Require medical attention, may be permanent.

(3) High – can cause death or severely disabling conditions.

g. Exposure rate. Some chemicals are more toxic by one exposure rather than by another. For example, onion juice vapors irritate the eyes, but the skin contact with onion juice produces little or no effect.

- h. Dosage depends on the following:
- (1) How much you are exposed to each time.
 - (2) How long each exposure lasted.
 - (3) How often you are exposed.

- i. Individual differences, such as the following:
- (1) Work practices.
 - (2) Age and size.
 - (3) General physical and emotional health.
 - (4) Allergies and sensitivities.
 - (5) Level of exertion.

Note. Combination of chemicals in the body, which depends on what medications you are taking and whether or not you smoke tobacco or drink alcoholic beverages.

- j. There are three basic methods of controlling chemical hazards.
- (1) Engineering controls.
 - (a) Substitution – Replacing a chemical process or piece of equipment with a less hazardous or more efficient one.
 - (b) Isolation – Using an enclosure, barrier or safe distance to separate workers from exposure hazards.
 - (c) General ventilation – Mixing an airborne hazard with fresh air to reduce exposure levels. This is only suitable for hazards of low toxicity that mix readily with air (for example fans and make-up air vents).
 - (d) Local exhaust ventilation – Capturing an airborne hazard as it is released and taking it out of the workplace to eliminate exposure (for example hoods, slots, and dust collectors).
 - (2) Administrative controls.
 - (a) Documentation – Information and training example warning labels, MSDS, hazardous chemical inventory, and written hazard communication program.
 - (b) Work Practices – Examples include vacuuming toxic dusts, proper storage and handling, and correct disposal of chemical wastes.

(c) Monitoring – Checking the effectiveness of other controls for example air and wipe samples for area monitoring personal sampling for individual monitoring medical exam and laboratory tests).

Note. Always be alert for uncontrolled chemical hazards in your workplace. Check faulty equipment, leaks spills, and unusual smells.

(3) Personal protective equipment (PPE). PPE puts a barrier between the hazard and the individual who wears it. It can protect against both physical hazards and health hazards.

(a) Protective gloves and clothing (for example hats, boots, and gloves).

(b) Eye and face protection (for example safety glasses, splash goggles, face masks, and shields).

(c) Air-purifying respirators (for example respirators with a cartridge or filter that removes contaminants from the air you breathe).

(d) Air supplied respirators (for example self-contained units that supply air from a tank carried on the back and air-line units that provide air from a remote source).

Note. PPE must be matched to the specific hazard. For example, cloth gloves are useless for protection against a corrosive liquid.

Note. Conduct a check on learning and summarize the learning activity.

Check on Learning

Determine if the students have learned the material presented by soliciting student questions and explanations. Ask the students the following questions and correct student misunderstandings.

- Q. What are the three goals the Hazard Communication Standard (backed by OSHA) strives to follow?
- A. Reduce the probability of injury and illness caused by hazardous chemicals in the workplace. Identify and evaluate chemical hazards. Establish uniform requirements for communicating information about chemical hazards to both management and workers.
- Q. What document provides up-to-date information about chemical hazards, control measures, and first aid?
- A. An MSDS.
- Q. Name the three basic forms of a chemical?
- A. Solids, liquids, and gases.
- Q. What are the degrees of toxicity?
- A. Low, medium, and high.

REVIEW/SUMMARIZE: We have discussed the HAZCOM mandated by OSHA. It is the law and we must conform to the standard. All manufactures and employers are accountable for their shortcoming and actions.

TESTING REQUIREMENTS: This lesson is not examinable.

FEEDBACK REQUIREMENT: Rapid, immediate feedback is essential to effective learning. Schedule and provide feedback on the evaluation and any information to help answer students' questions about the test. Provide remedial as needed.

TRANSITION TO THE NEXT LESSON: The next lesson will be Safety Procedures and Hand and Arm Signals.

This page intentionally left blank.

CHAPTER 5

LESSON OUTLINE FOR SAFETY PROCEDURES AND HAND AND ARM SIGNALS**5-1. LESSON TITLE: SAFETY PROCEDURES AND HAND AND ARM SIGNALS****INSTRUCTOR GUIDANCE:**

- Ensure facilities, equipment, and training materials are prepared prior to class start time.
- Must be thoroughly prepared by studying this lesson and identified reference material.
- Inform students of the terminal learning objective (TLO) requirements before teaching each lesson.
- Use the appropriate Slides (Appendix A) designated in the lessons, Force Protection Annex (Appendix B), 60 Rules of Safety for Operating Material Handling Equipment (MHE) (Appendix C), Practical Exercises (Appendix D), Handouts and Worksheets (Appendix E) needed to teach this class.
- Ask check on learning questions throughout each lesson.
- Pass out outline of presentation prior to class.

RISK ASSESSMENT LEVEL: Moderate.

ADDITIONAL COMMENTS AND INFORMATION: Recommended instructional time is 2 hours (1.0 Conference ELO A and 1.0 Conference ELO B).

INSTRUCTIONAL LEAD IN: Welcome the students to the Kalmar 53,000-pound RT-240 Rough Terrain Container Handler (RTCH), Safety Procedures, and Hand and Arm Signals class. Instructors should use the following slides from Appendix A:

- Slide #1 through Slide #22 for ELO B (Ground Guides for Backing and Operation of Material Handling Equipment (MHE)).

Section I. Introduction

MOTIVATOR: Using personal experience or related story, give a brief explanation of why this lesson is important to the student.

TERMINAL LEARNING OBJECTIVE:

Action: After this lesson, the student will be knowledgeable of the responsibilities of the Hand and Arm Signals and Ground Guides for Backing Military Material Handling Equipment (MHE) and with the safety summary and warnings concerning the operation of the Kalmar 53,000-pound RT-240 RTCH and characteristics and capabilities of the Kalmar RT-240 RTCH.

Condition: Given TM 10-3930-675-10-1, TM 10-3930-675-10-2, FM 21-60, FM 55-17, FM 21-305, and a Kalmar 53,000-pound RT-240 RTCH. The student will demonstrate the use of Ground Guides for Backing Military Material Handling Equipment (MHE) and Hand and Arm Signals for Loading Ship's, Rail Cars, and Aircraft, During Movement Within An Assembly Area and/or a Field Site Operations Area. Become familiar with the safety summary and warnings concerning the operation of the Kalmar 53,000-pound RT-240 RTCH and demonstrate the operation of the Kalmar RT-240 RTCH.

Standard: To receive a "GO" for this lesson, the student will be familiar with the Ground Guides for Backing Military Material Handling Equipment (MHE), Hand and Arm Signals for Loading Ship's, Rail Cars, and Aircraft, and be familiar with the safety and warnings operation of the Kalmar 53,000-pound RT-240 RTCH and the student must correctly answer all check on learning questions.

SAFETY REQUIREMENTS:

- Instructor will use Appendix C (60 Rules of Safety for Operating Material Handling Equipment (MHE)) to conduct a safety briefing before operations begin each morning and maintain direct supervision throughout the day.
- Safety will be discussed and practiced throughout this lesson.
- Safety clothing (hard hats, gloves, and steel-toed boots, and hearing protection) will be worn at all times while performing these tasks.
- One instructor will be with the MHE at all times with one student without TA 50. Student will sound warning before movement. Back only with ground guides present using the 3-point system. Look before backing and keep looking back until stopped. NEVER back long distances and NEVER use mirrors for backing.

ENVIRONMENTAL CONSIDERATIONS: It is the responsibility of all Soldiers and DA civilians to protect the environment from damage. AR 200-1 delineates TRADOC responsibilities to integrate environmental requirements across DOTMLPF and ensure all training procedures, training materials, and training doctrine, to include sound environmental practices and considerations. The Army's environmental standard is to be a national leader in environmental and natural resource stewardship for present and future generations. This training support package meets this standard.

EVALUATION: Inform the Soldiers how, when, and where performance of the TLO will be evaluated.

ENABLING LEARNING OBJECTIVE A**5-2. LESSON TITLE: MATERIAL HANDLING EQUIPMENT (MHE) SAFETY SYMBOLS**

TERMINAL LEARNING OBJECTIVE: Inform students of the terminal learning objective (TLO) requirements. At the completion of this lesson you will:

Action: After this lesson, the student will be familiar with the safety summary and warnings concerning the operation of the Kalmar 53,000-pound RT-240 RTCH.

Condition: Given TM 10-3930-675-10-1, TM 10-3930-675-10-2, and a Kalmar 53,000-pound RT-240 RTCH.

Standard: To receive a "GO" for this lesson, the student will be familiar with the, safety and warnings concerning the operation of the Kalmar 53,000-pound RT-240 RTCH and the student must correctly answer all check on learning questions.

1. Learning Step/Activity 1. Link lesson plan to individual lesson taught.

WARNING

THIS WARNING SUMMARY CONTAINS GENERAL SAFETY WARNINGS AND HAZARDOUS MATERIALS WARNINGS THAT MUST BE UNDERSTOOD AND APPLIED DURING OPERATION AND MAINTENANCE OF THIS EQUIPMENT. FAILURE TO OBSERVE THESE PRECAUTIONS COULD RESULT IN SERIOUS INJURY OR DEATH TO PERSONNEL.

- a. Safety Symbols.

(1) Biological. Abstract symbol bug shows that a material may contain bacteria or viruses that present a danger to life or health.

(2) Chemical. Drops of liquid on hands shows that the material will cause burns or irritation to human skin or tissue.

(3) Electrical. Electrical wire to arm with electricity symbol running through human body shows that shock hazard is present.

(4) Eye protection. Person with goggles shows that the material will injure the eyes.

(5) Fire. Flame shows that a material may ignite and cause burns.

(6) Flying particles. Arrows bouncing off face with face shields shows that particles flying through the air will harm face.

(7) Heavy parts. Hand with heavy object on top shows that heavy parts can crush and harm.

(8) Hot area. Hand over object radiating heat shows that part is hot and can burn.

(9) Radioactive. Identifies a material that emits radioactive energy and can injure human tissue or organs.

(10) Vapor. Human figure in a cloud shows that material vapors present a danger to life or health.

b. Check On Learning. Conduct a check on learning and summarize the learning activity.

2. Learning Step/Activity 2. Hazards of Operating the Kalmar 53,000-pound RT-240 RTCH.

a. Carbon Monoxide (Exhaust Gases) Can Kill.

(1) Carbon monoxide is a colorless, odorless, deadly poison which, when breathed, deprives the body of oxygen and causes suffocation.

(2) Exposure to air containing carbon monoxide produces symptoms of headaches, dizziness, and loss of muscular control, apparent drowsiness, and coma.

(3) Permanent brain damage or death can result from severe exposure.

(4) Carbon monoxide occurs in exhaust fumes of internal combustion engines.

(5) Carbon monoxide can become dangerously concentrated under conditions of inadequate ventilation.

(6) The following precautions must be observed to ensure safety of personnel when engine of truck is operated.

(a) DO NOT operate truck engine in enclosed areas.

(b) DO NOT idle truck engine without adequate ventilation.

(c) DO NOT drive truck with inspection plates or cover plates removed (engine compartment covers).

Note. The best defense against carbon monoxide poisoning is good ventilation!

(7) BE ALERT for exhaust poisoning symptoms. They are:

(a) Headache.

(b) Dizziness.

(c) Sleepiness.

(d) Loss of muscular control.

(8) If you see another person with exhaust poisoning symptoms:

- (a)** Remove person from area.
- (b)** Expose to fresh air.
- (c)** Keep person warm.
- (d)** Do not permit physical exercise.
- (e)** Administer cardiopulmonary resuscitation (CPR), if necessary.

(9) Notify a medic.

(10) BE AWARE. The field protective mask for nuclear, biological, chemical (NBC) protection will not protect you from carbon monoxide poisoning.

b. Batteries.

(1) To avoid injury, eye protection and acid-resistant gloves must be worn when working around batteries.

(a) Do not smoke, use open flame, make sparks, or create other ignition sources around batteries. If a battery is giving off gases, it can explode and cause injury to personnel.

(b) Remove all jewelry such as rings, identification (ID) tags, watches, and bracelets. If jewelry or tool contacts a battery terminal, a direct short will result in instant heating and can cause damage to equipment and/or injury to personnel.

(2) Sulfuric acid contained in batteries can cause serious burns. If battery corrosion or electrolyte makes contact with skin, eyes, or clothing, take immediate action to stop the corrosive burning effects. Failure to follow these procedures may result in serious injury or even death to personnel.

(a) Eyes. Flush with cold water for no less than 15 minutes and seek medical attention immediately.

(b) Skin. Flush with large amounts of cold water until all acid is removed. Seek medical attention as required.

(c) Internal. If corrosion or electrolyte is ingested, drink large amounts of water or milk. Follow with milk of magnesia, beaten egg, or vegetable oil. Seek medical attention immediately.

(d) Clothing/Equipment. Wash area with large amounts of cold water. Neutralize acid with baking soda or household ammonia.

c. Compressed Air.

(1) Compressed air used for cleaning purposes should never exceed 30 psi (207 kPa).

(2) Wear protective clothing (goggles/shield, gloves, and so on).

(3) Use CAUTION to avoid injury to personnel.

d. Diesel Fuel Handling.

(1) DO NOT smoke or permit any open flame in area of truck while you are servicing diesel fuel system. Be sure hose nozzle is grounded against filler tube during refueling to prevent static electricity. Failure to follow this warning may result in injury to personnel or equipment damage.

(2) DO NOT perform fuel system checks, inspections, or maintenance while smoking or near fire, flames, or sparks. Fuel may ignite, causing damage to vehicle and injury or death to personnel.

(3) Operating personnel must wear fuel-resistant gloves when handling fuels. If exposed to fuel, promptly wash exposed skin and change fuel-soaked clothing.

e. Dry Cleaning Solvents.

(1) Dry cleaning solvents P-680 type II is toxic and flammable. Wear protective goggles and gloves and use only in a well-ventilated area. Avoid contact with skin, eyes, and clothes and do not breathe vapors.

(2) Do not use near open flame or excessive heat. The solvent's flash point is 200 degrees Fahrenheit (F), 94 degrees Celsius (C).

(3) If you become dizzy while using dry cleaning solvent, get fresh air immediately and get medical help. If solvent contact eyes, wash your eyes and get medical aid immediately.

f. Fire Extinguisher.

(1) Discharging large quantities of dry chemical fire extinguisher in cab may result in temporary breathing difficulty during and immediately after the discharge event.

(2) If at all possible, discharge fire extinguisher from outside the cab.

(3) Ventilate cab thoroughly prior to reentry.

g. Hazardous Waste Disposal. When servicing this vehicle, performing maintenance, or disposing of materials (such as engine coolant, transmission fluid, lubricants, battery acids or batteries, and chemical agent resistant coating [CARC] paint) consult your unit/local hazardous waste disposal center or safety office for local regulatory guidance.

Note. If further information is needed, please contact the Army Environmental Hotline at 1-800-872-3845.

h. Infrared (IR) Lights. DO NOT look directly at IR source without eye protection and maintain a minimum of 12 inches from energized IR lights to prevent possible eye discomfort or damage.

i. NBC Exposure. If NBC exposure is suspected, all air cleaner media should be handled by personnel wearing protective equipment. Consult your NBC Officer or NBC NCO for appropriate handling or disposal procedures. Use the decal shown in Figure 5-1 if exposed to NBC.

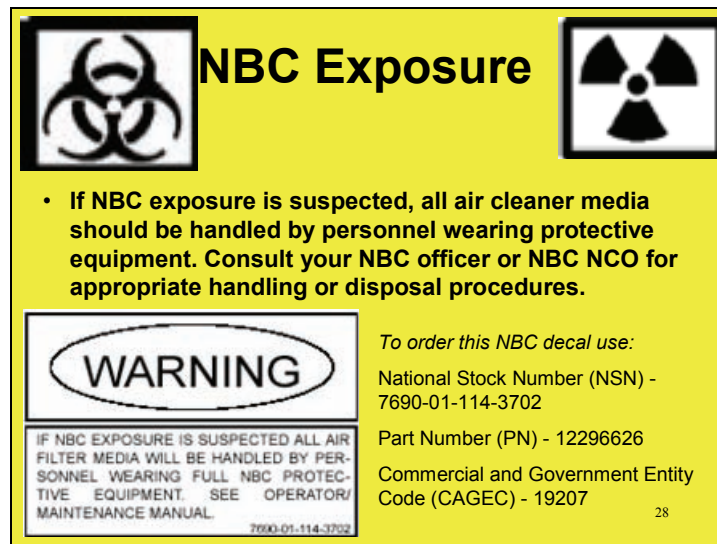

Figure 5-1. NBC Exposure

3. Learning Step/Activity 3. Kalmar RT-240 RTCH Operating Cautions.

a. Pressurized Cooling System.

(1) DO NOT service cooling system unless engine has been allowed to cool down. DO NOT remove radiator cap. Add coolant only to expansion tank. This is a pressurized cooling system and escaping steam or hot coolant will cause serious burns.

(2) Wear effective eye, glove, and skin protection when handling coolants. Failure to do so may cause injury.

b. Slave-Starting.

(1) When slave-starting truck, use NATO slave cable that DOES NOT have loose or missing insulation.

(2) DO NOT proceed if suitable cable is not available.

(3) DO NOT use civilian-type jumper cables.

c. Operation Safety.

(1) DO NOT allow riders on the truck. Failure to follow this warning may result in serious injury or death to personnel.

(2) BE ALERT for personnel in the area while operating truck. Always check to ensure area is clear of personnel and obstructions before moving. Failure to follow this warning may result in serious injury or death to personnel or damage to equipment.

(3) ALL FOUR corners of tophandler must be in contact with container when locking or releasing the twistlocks. In addition, during release all four corners of the container must be resting firmly on the

surface supporting it. Failure to follow this warning may result in injury or death to personnel or damage to equipment.

(4) If the indicator lamps for the overload system are inoperative, the RTCH must not be operated. Safe operation may be affected if the truck is used when the indicator lamps are defective. Failure to follow this warning may result in injury or death to personnel or damage to equipment.

(5) NEVER operate the RTCH or move the load near a power line or overhead wires. Failure to follow this warning may result in injury or death to personnel or damage to equipment.

(6) Truck must not be driven when container load is in fully raised position. Truck is less stable when traveling with the load in a raised position. Maintain proper transport mode load height and position when driving to prevent forward tipping. Failure to follow this warning may result in injury or death to personnel or damage to equipment.

(7) Never leave the operator's position without applying the parking brake. Failure to follow this warning may result in injury or death to personnel or damage to equipment.

(8) Never use starting fluids or spray to aid in starting the engine. Failure to follow this warning may result in injury or death to personnel or damage to equipment.

(9) Always use a ground guide when driving RTCH up or down ramps in preparation for highway, marine, or air transport. Failure to use ground guides may result in an accident, causing injury or death to personnel or damage to equipment.

d. Work Safety.

(1) Ether is highly flammable and explosive. DO NOT perform ether quick-start system checks or inspections while smoking or near fire, flame, or sparks. Failure to follow this warning may cause a fire and explosion, causing serious injury or death to personnel.

(2) Avoid breathing cold start system fluid vapors. Wear goggles and fuel-resistant gloves when handling fluid. Failure to follow this warning may cause serious injury or death to personnel.

(3) Lifting cables, chains, hooks, and slings for lifting truck must be in good condition and suitable capacity. Failure to following this warning may result in injury or death to personnel and damage to equipment.

(4) Improper use of lifting equipment and improper attachment of cables to vehicle can result in serious injury or death to personnel.

Note. Conduct a check on learning and summarize the ELO.

Check on Learning

Determine if the students have learned the material presented by soliciting student questions and explanations. Ask the students the following questions and correct student misunderstandings.

- Q. What is the potential hazard associated with the batteries of the Kalmar RT-240 RTCH?
A. Flammable gas, chemical burn, corrosive fluid, and electrical hazard.
- Q. What are the symptoms of exhaust (carbon monoxide) poisoning?
A. Headache, dizziness, sleepiness, and loss of muscular control.
- Q. What color is carbon monoxide?
A. Colorless.
- Q. What type of hazard does the illustration with arrows bouncing off the face shield represent?
A. Flying particles.
- Q. Which hazard symbol represents chemical burns or skin irritation?
A. Chemical.
- Q. What type injury or effect may result from exposure to a fire extinguisher discharge?
A. Difficulty breathing.

ENABLING LEARNING OBJECTIVE B**5-3. LESSON TITLE: GROUND GUIDES FOR BACKING AND OPERATION OF MATERIAL HANDLING EQUIPMENT (MHE)**

TERMINAL LEARNING OBJECTIVE: Inform students of the terminal learning objective (TLO) requirements.

Action: After this lesson, the student will be familiar with Ground Guides for Backing Military Material Handling Equipment (MHE).

Condition: Given FM 21-60, FM 55-17, and FM 21-305. After this lesson, the student will be familiar with Ground Guides for Backing Military Material Handling Equipment (MHE) and Hand and Arm Signals for Loading Ship's, Rail Cars, and Aircraft, and during Movement Within An Assembly Area, and/or a Field Site Operations Area for the Kalmar 53,000-pound RT-240 RTCH.

Standard: To receive a "GO" for this lesson, the student will be familiar with the Ground Guides for Backing Military Material Handling Equipment (MHE) and Hand and Arm Signals for Loading Ship's, Rail Cars, and Aircraft Operation of the Kalmar 53,000-pound RT-240 RTCH and the student must correctly answer all check on learning questions.

1. Learning Step/Activity 1. Link lesson plan to individual lesson taught.

a. Vehicle Backing for Operation of Military Material Handling Equipment (MHE), Cranes, RTCH and Forklifts in General.

(1) Visual signals are any means of communication that require sight and can be used to transmit prearranged messages rapidly over short distances.

(2) This includes the devices and means used for the recognition and identification of friendly forces. Signals are illustrated as normally seen by the viewer.

(3) Some signals are illustrated in oblique, right angle, or overhead views for clarity.

b. Signals to Control Vehicle Drivers or Crews.

(1) These are the arm-and-hand and light signals used to guide and direct vehicles.

(2) Flashlights are used at night to direct vehicles.

(3) Whenever possible, in order to preserve the driver's night vision, blue filters should be used.

(4) Chemical lights can also be used and have less effect on the driver's night vision.

c. Types of Visual Signals.

(1) The most common types of visual signals are arm-and-hand, flag, pyrotechnic, and ground-to-air signals.

(2) However, Soldiers are not limited to the types of signals discussed and may use what is available.

(3) Chemical light sticks, flashlights, and other items can be used provided their use is standardized within a unit and understood by Soldiers and units working in the area.

(4) The only limit is the Soldier's initiative and imagination.

d. Limitations.

(1) Visual signals have certain limitations.

(2) The range and reliability of visual communications are significantly reduced during periods of poor visibility and when terrain restricts observation.

(3) They may be misunderstood.

(4) They are vulnerable to enemy interception and may be used for deception purposes.

e. Vehicle Backing.

(1) Back slowly. In a vehicle with standard gears, you cannot control your speed safely while backing unless you use the clutch as well as the accelerator. Always come to a full stop before shifting into forward gear.

(2) Keep looking back until you have stopped. If you shift your eyes to the front as soon as you are ready to stop, you will be backing blindly for several feet.

(3) When backing in very close quarters (such as a driveway) or when visibility through the rear window is poor, you may find it necessary to use your right hand on the steering wheel while you look out the left window to see where you are going.

(4) Never open either door while your vehicle is in motion. At best, backing is more dangerous than going forward. You cannot see as well and your vehicle is harder to control. Before you back even a short distance, make sure there are no people around.

(5) Many people have been crushed under the wheels of military equipment while working or walking in the work area of military equipment.

(6) Never back long distances unless absolutely necessary. It is much safer to turn around and cover the distance going forward.

(7) Ground guides must be trained in standard hand and arm signals and flashlight signals before guiding a wheeled vehicle.

(8) Hand and arm signals are the basic method used for ground guiding. Drivers and ground guides will coordinate signals before ground guide operations. Examples of hand and arm signals are in FM 21-305 and FM 55-17. Additional hand and arm signals are in FM 21-60.

(9) Voice signals between a ground guide and driver can be misunderstood and should not be used except in an emergency.

(10) Before a wheeled vehicle is started for movement, a member of the crew or the driver must walk completely around the vehicle to ensure no one or no object is in danger from the vehicle's movement.

- (11) At no time will ground guides run or walk backwards while guiding a vehicle.
 - (12) The ground guides should keep 10 yards between themselves and the vehicle front or rear corners.
 - (13) Ground guides should never be positioned directly behind the vehicle.
 - (14) Ground guides will not position themselves between the vehicle being guided and another object where an inadvertent engine surge or momentary loss of vehicle control could cause injury or death.
 - (15) Drivers of vehicles will immediately stop their vehicles if they lose sight of even one ground guide or note that the guide is dangerously positioned between the vehicle and another object.
 - (16) Drivers of vehicles in such cases will secure their vehicle, dismount, and make an on-the-spot correction before commencing operations.
 - (17) Use the procedure below when there is only one ground guide or when a ground guide is not available, such as in the civilian domain. The ground guide or the vehicle driver will dismount and walk completely around the vehicle.
- f. Verify Clearance. Determine visual clear distance with a ground reference point from the cab of the vehicle.
- (1) Mount the vehicle, sound the horn, and back to the rear of the preselected ground reference point. Stop and repeat the process as necessary until the desired vehicle position is obtained.
 - (2) Only one ground guide gives signals to the driver.
 - (3) Be sure that everyone involved (the driver and ground guides) understand who will give the signal and who will receive it before any movement is done.
 - (4) If sight between the driver and the ground guide making the signal is lost, the driver must stop the vehicle until the signal is again visible or the confusion is cleared up.
 - (5) During movement within an assembly area, wheeled vehicles require ground guides when moving forward and when backing.
 - (6) Ground guides are also required when vehicles enter a field site operations area.
 - (7) At night, the best method to ground guide a vehicle into the area is to use a screened flashlight.
 - (8) Guides move forward to make sure the way is clear and then turn around to face the vehicle and give the proper signal with the flashlight.
 - (9) The driver moves the vehicle forward until the flashlight signal goes out. Then he/she stops the vehicle.
 - (10) This process is repeated as the vehicle is moved forward to its final stop.

(11) Ground guides are required when wheeled vehicles are backed. However, the number of ground guides used is determined by visibility restrictions (cargo, darkness, and so forth).

(12) The horn will be sounded before any backing operation is done.

(13) When backing at night, use the same flashlight procedures to safely back the vehicle.

g. Vehicle Backing.

Note. View Slide # 1.

(1) One point guide.

(a) Forward movement only when one guide is available.

(b) Never back military equipment with one guide.

Note. View Slide # 2.

(2) Two point guide. Operation and non-congested area, minimum of two ground guides when backing a vehicle.

Note. View Slide # 3.

(3) Three point guide.

(a) In a congested area when backing a vehicle there should be three ground guides.

(b) This method should be used during all loading exercises.

Note. Because of the visibility restrictions, this is the only safe method that can be used with MHE, 40-ton crane, RTCHs, and forklifts.

2. Learning Step/Activity 2. Hand and Arm Signals for Loading Ship's, Rail Cars, and Aircraft and During Movement Within an Assembly Area or a Field Site Operations Area.

Note. Hand and arm signals should be given without gloves and hand away from body.

a. Hand and Arm Signals.

Note. View Slides # 4, # 5, # 6 and # 7.

(1) Ready. Place both palms with open hands on head.

(2) Move load very slowly. With hands together and pointing up, rub palms together.

(3) Stop all movement. Both fists should be closed, facing forward, and raised above the shoulder.

(4) Dog down. With palms facing forward and together at thumbs.

b. Boom Movement.

Note. View Slides # 8 thru # 33.

(1) Boom up. Fist closed, thumb extended and pointing up.

(2) Boom down. Fist closed, thumb extended and pointing down.

(3) Boom out. Fist closed, thumb extended and pointing outward.

(4) Boom in. Fist closed, thumb extended and pointing inward.

(5) Slew left. Right hand opened with palm facing forward and pointing in direction of left movement.

(6) Slew right. Left hand opened with palm facing forward and pointing in direction of right movement.

(7) Forks hook load tophandler up. Forefinger extended, pointed up.

(8) Forks hook load tophandler down. Forefinger extended, pointed down.

(9) Move both forks in, closer together or tophandler 20-foot position. Forefingers extended and pointed in.

(10) Move both forks out or tophandler out to 40-foot position. Forefingers extended and pointed out.

(11) Move forks, load right or side shift tophandler right. Left hand pointed forward with palm facing in, right fist closed with forefinger pointed to palm of left hand.

(12) Move forks, load left or side shift tophandler, left. Right hand pointed forward with palm facing in, left fist closed with forefinger pointed to palm of right hand.

(13) Hold left fork move right fork in. Right fist closed, left forefinger extended and pointed to right fist.

(14) Hold right fork move left fork in. Left fist closed, right forefinger extended and pointed to left fist.

(15) Hold right fork move left fork out. Left fist closed, right forefinger extended and pointed out.

(16) Hold left fork move right fork out. Right fist closed, left forefinger extended and pointed out.

(17) Oscillate left side up, right side down. Left hand displaying the V-sign and pointed down. Right hand displaying the V-sign and pointed up.

(18) Oscillate right side up, left side down. Left hand displaying the V-sign and pointed up. Right hand displaying the V-sign and pointed down.

(19) Tilt load out or forks up. Left hand displaying the V-sign and pointed up. Right hand pointed up with palm facing forward.

(20) Tilt load in or forks down. Right hand displaying the V-sign and pointed up. Left hand pointed up with palm facing AFT.

(21) Lock twistlocks or hook up complete. Both fists facing each other.

(22) Unlock twistlocks or unlock load. Both hands extended pointing in, palms facing back.

(23) Level load level forks level tophandler. Right hand extended, pointed in, with palm facing down.

(24) Center and level load, forks, or tophandler. Right hand extended, pointed in, palm facing down, left hand extended, pointing up, with palm facing in.

(25) Rotate right end of load, tophandler or forks clockwise. Rotate right hand palm up. Left forefinger extended and pointed in direction of movement.

(26) Rotate left end of load, forks, or tophandler counter clockwise. Rotate left hand palm up. Right forefinger extended and pointed in direction of movement.

Check on Learning

Determine if the students have learned the material presented by soliciting student questions and explanations. Ask the students the following questions and correct misunderstandings.

- Q. At what distance should a ground guide keep between themselves and the vehicle front or rear corners?
A. 10 yards.
- Q. If a driver loses sight of a ground guide or note that a guide is dangerously positioned between the vehicle and another object. What should the driver do?
A. Stop immediately.
- Q. What is the hand signal to oscillate left side up, right side down?
A. Left hand displaying the V-sign, and pointed down. Right hand displaying the V-sign and pointed up.
- Q. What is the hand signal to tilt load out or forks up?
A. Left hand displaying the V-sign, and pointed up. Right hand pointed up with palm facing forward.

REVIEW/SUMMARIZE: We have discussed the Material Handling Equipment (MHE) Safety Symbols, Ground procedures for backing Material Handling Equipment and Hand and Arm Signals. These lessons support Army operations doctrine and concepts and discuss the safe operation of the Kalmar RT-240 RTCH.

TESTING REQUIREMENTS: Describe how the student must demonstrate accomplishment of the TLO standard. Refer student to the Student Evaluation Plan. This lesson is examinable during performance test.

FEEDBACK REQUIREMENT: Rapid, immediate feedback is essential to effective learning. Schedule and provide feedback on the evaluation and any information to help answer students' questions about the test. Provide remedial training as needed.

TRANSITION TO THE NEXT LESSON: Read your syllabus for the next lesson, location, and study assignment.

CHAPTER 6

LESSON OUTLINE FOR THE KALMAR RT-240 ROUGH TERRAIN CONTAINER HANDLER FAMILIARIZATION AND PREVENTIVE MAINTENANCE CHECKS AND SERVICES

6-1. LESSON TITLE: KALMAR RT-240 ROUGH TERRAIN CONTAINER HANDLER FAMILIARIZATION AND PREVENTIVE MAINTENANCE CHECKS AND SERVICES

INSTRUCTOR GUIDANCE:

- Ensure facilities, equipment, and training materials are prepared prior to class start time.
- Must be thoroughly prepared by studying this lesson and identified reference material.
- Use the appropriate Slides (Appendix A) designated in the lessons, Force Protection Annex (Appendix B), 60 Rules of Safety for Operating Material Handling Equipment (MHE) (Appendix C), Practical Exercises (Appendix D), Handouts and Worksheets (Appendix E) needed to teach this class.
- Inform students of the terminal learning objective (TLO) requirements before teaching each lesson.
- Ask check on learning questions throughout each lesson.
- Pass out outline of presentation prior to class.

RISK ASSESSMENT LEVEL: Moderate

ADDITIONAL COMMENTS AND INFORMATION: Recommended instructional time is 24 hours (7.0 Conference, 13.0 Practical Exercise (PE) on controls and instruments, and 4.0 PE (Preventive Maintenance Checks and Services (PMCS)).

INSTRUCTIONAL LEAD IN: Welcome the students to the Kalmar 53,000-pound RT-240 RTCH, Familiarization and PMCS class.

Section I. Introduction

TERMINAL LEARNING OBJECTIVE: Inform students of the terminal learning objective (TLO) requirements.

Action: After this lesson, the student will be knowledgeable of the responsibilities of the operators, controls, and instruments. Operational maintenance, safety, and basic knowledge and skills to operate the Kalmar 53,000-pound RT-240 RTCH.

Condition: Given TM 10-3930-675-10-1, TM 10-3930-675-10-2, and a Kalmar 53,000-pound RT-240 RTCH. The student will demonstrate the operation and use of the Kalmar RT-240 RTCH Boom and Tophandler Joystick Controls. Rotating, side shifting, lifting, lowering, oscillation, and tilt angles. Twistlocks and twistlocks indicator lights. Demonstrate engine starting procedures of the Kalmar RT-240 RTCH cold and hot starts. Demonstrate shutting down engine, apply parking brake, and retracting and fully lowering the boom. Place transmission control lever in neutral and placing master switch to OFF.

Standard: To receive a "GO" for this lesson, the student will be familiar with the starting/operating/stopping procedures and operation of the boom and tophandler with the Kalmar 53,000-pound RT-240 RTCH.

1. Learning Step/Activity 1. Link lesson plan to individual lesson taught - Introduction to Kalmar RTCH and Familiarization.

MOTIVATOR: Using personal experience or related story, give a brief explanation of why this lesson is important to the student.

SAFETY REQUIREMENTS:

- Instructor will use Appendix C (60 Rules of Safety for Operating Material Handling Equipment (MHE)) to conduct a safety briefing before operations begin each morning and maintain direct supervision throughout the day.
- Safety will be discussed and practiced throughout this lesson.
- Safety clothing (hard hats, gloves, and steel-toed boots, and hearing protection) will be worn at all times while performing these tasks.
- One instructor will be with MHE at all times with one student without TA 50. Student will sound warning before movement. Back only with ground guides using 3-point system. Look before backing and keep looking back until stopped. Never back long distances and never use mirrors for backing.

RISK ASSESSMENT LEVEL: Moderate.

ENVIRONMENTAL CONSIDERATIONS: It is the responsibility of all Soldiers and DA civilians to protect the environment from damage. AR 200-1 delineates TRADOC responsibilities to integrate environmental requirements across DOTMLPF and ensure all training procedures, training materials, and training doctrine, to include sound environmental practices and considerations. The Army's environmental standard is to be a national leader in environmental and natural resource stewardship for present and future generations. This training support package meets this standard.

EVALUATION: Inform the Soldiers how, when, and where performance of the TLO will be evaluated.

INSTRUCTIONAL LEAD IN: Transition students to presentation using personal experience or related story explain why this lesson is important to the students. Instructors should use the following slides from Appendix A:

- Slide #34, Slide #35, and Slide #36 for ELO A (Characteristics and Capabilities).
- Slide #37 through Slide #46 for ELO B (Gauges and Switch Panels Controls).
- Slide #47 through Slide #74 for ELO C (Operator Controls and Instruments).
- Slide #75 through Slide #91 for ELO D, Intermediate Learning Objective 1 (Familiar With Preventive Maintenance Checks and Services).
- Slide #92 through #96 for ELO D, Intermediate Learning Objective 2 (Relieving Hydraulic System Pressure and Caging and Uncaging the Parking Brake).
- Slide #97 through #106 for ELO D, Intermediate Learning Objective 3 (Lubrication Order and Reading On-Board Computer).

ENABLING LEARNING OBJECTIVE A

6-2. LESSON TITLE: CHARACTERISTICS AND CAPABILITIES

Action: After this lesson, the student will be familiar with the characteristics and capabilities of the Kalmar 53,000-pound RT-240 RTCH.

Condition: Given TM 10-3930-675-10-1, TM 10-3930-675-10-2, and a Kalmar 53,000-pound RT-240 RTCH. After this lesson, the student will be familiar with the characteristics, major components, and capabilities of the Kalmar RT-240 RTCH.

Standard: To receive a "GO" for this lesson, the student will be familiar with the characteristics and capabilities of the Kalmar 53,000-pound RT-240 RTCH.

1. Learning Step/Activity 1. Link lesson plan to individual tasks taught - Characteristics of the Kalmar RT-240 RTCH.

Note. View Slide # 34.

Note. State this is an illustration of the Kalmar 53,000-pound RT-240 RTCH.

a. The Kalmar RT-240 RTCH is designed to lift, move, stack, or unstack 20-foot and 40-foot by 8-foot wide International Organization for Standardization (ISO) containers.

b. The Kalmar RT-240 RTCH has a lifting capacity of 53,000 pounds and operates on hard and/or unimproved surfaces to include beach operations.

c. The Kalmar RT-240 RTCH can be used as a forklift. A kit is operator installed and attaches to the tophandler. The fork tines are adjustable from 24 inches center to center to 81.5 inches center to center. The lift capacity is 44,000 pounds.

2. Learning Step/Activity 2. Link lesson plan to individual tasks taught - Container Handling Capabilities.

- Stack or unstack 8-foot high military-owned demountable container (MILVAN) stacked three (3) high with a gross weight of 53,000 pounds in the first row.
- Stack or unstack 8-foot high MILVAN stacked three (3) high with a gross weight of 27,500 pounds in the second row.
- Stack or unstack 4.3-foot high MILVAN stacked seven (7) high.

a. Container Tophandler:

- Adjusts to 20-foot or 40-foot MILVAN lengths.
- Oscillates 7 degrees left and right.
- Rotates 195 degrees clockwise and 105 degrees counterclockwise.
- Tilts 8 degrees forward and 12 degrees rearward.

- Side shifts right or left 15 inches from center.
- The maximum speed of the Kalmar RT-240 RTCH is 24 mph on level ground without a load.
- The maximum speed of the Kalmar RT-240 RTCH is 15 mph on level ground with a load.
- The maximum fording depth is 60 inches.
- Operate in temperatures from –25 degrees to 125 degrees Fahrenheit, and to –40 degrees Fahrenheit with the arctic kit installed.

b. Engine and Transmission Features:

- Electronically controlled 400 hp, six-cylinder turbocharged engine.
- Electronic semi-automatic shift controlled transmission with four ranges forward and three ranges reverse. Operator selects ranges and the Electronic Control Module (ECM) controls shift points.
- The drive axles provide traction for two or four wheel drive.
- Limited slip differentials and multi-disc wet brakes are an integral part of the axle assemblies. The multi-disc wet brakes are hydraulically cooled to prevent overheating. The accumulator stores energy for the emergency braking system.
- The parking brake is hydraulically released and spring applied by disc brake assemblies mounted on the front and rear differentials.
- The steering system is capable of two wheel, four-wheel, crab, and emergency modes of operation.
- The operator's cab has a fully adjustable operator's seat, fresh air ventilation system, and heater/defroster/air conditioning system.
- The operator's controls includes adjustable steering wheel; accelerator and brake pedals; transmission range selector; steering mode selection rocker switches; and single joystick control for all boom, tophandler, and forklift operations.

c. Transport Modes:

- Self-Deployment.
- Highway Transport.
- Rail Transport.
- Marine Transport.
- Air Transport.

Note. View Slide # 35

Major Components (Left Side view)

Boom Assembly – Two sectioned telescoping boom.
Boom Lift Cylinders – Dual mounted; one mounted each side of boom.
Operator's Cab – Single door mounted on the left side of cab.
Boom Support – Dual mounted.
Frame and Counterweight.
Remote Hydraulic Control Compartment – House five hydraulic levers and a shut-off valve.
Dolly Wheels Storage Compartment – Contains four dolly wheels and load/unloading ramp.
Master Battery Switch – Used to turn main battery power on or off.
Slave Receptacle – Used to slave (jump) start the engine. Locate on both sides of vehicle.
Battery Compartment – Contains four 12-volt batteries connected in a series-parallel providing 24 volts with a negative ground.
Twist Locks – Mounted at each corner of the tophandler.

Note. View Slide # 36.

Major Components (Right Side view).

Front service and Blackout Lights.
Coolant Expansion Tank.
Engine Compartment.
Hydraulic Reservoir.
Hydraulic Reservoir Sight Gauge.
Fuel Tank.
Rear Service and Blackout Lights.
Boogie Wheels.

Equipment Data

Engine manufactured by Cummins, Model #QSM 11, 400 hp @ 2,150 rpm, 6 cylinders 661 CID.
Fuel system is fully electronically controlled.
Transmission manufactured by ZF-Hydromedia, type 4 forward and 3 reverse speeds, automatic electronically controlled.
The gross vehicle weight rating (GVWR) is 118,000 pounds; GVWR with forklift kit is 128,400 pounds.

Capacities

Fuel Tank – 103 gallons U.S.
Coolant system – 23.7 gallons U.S.
Hydraulic Oil Reservoir – 180 gallons U.S.
Engine Crankcase with filter – 38.6 quarts U.S.
Transmission with filter – 36 quarts U.S.
Electrical System – 24 volt negative ground
Batteries – four each 12 volt batteries

Note. Conduct a check on learning and summarize the learning activity.

Check on Learning

Determine if the students have learned the material presented by soliciting student questions and explanations. Ask the students the following questions and correct student misunderstandings.

- Q. What is the gross vehicle weight of the Kalmar RT-240 RTCH with the forklift kit attached?
A. 128,400 pounds.
- Q. What is the maximum stacking height of standard MILVANS?
A. 3 high.
- Q. What is the maximum lifting capacity of the RTCH?
A. 53,000 pounds.
- Q. What is the maximum speed of the Kalmar RT-240 RTCH on level ground without a load?
A. 24 mph.
- Q. What is the maximum gear ranges of the Kalmar RT-240 RTCH?
A. 1st thru 4th forward and 1st thru 3rd in reverse.
- Q. Where is the container twistlocks located?
A. At each corner of the tophandler.
- Q. Which direction allows the most rotation of the tophandler from horizontal?
A. Rotating clockwise.

ENABLING LEARNING OBJECTIVE B

Note. Inform the students of the enabling learning objective (ELO) requirements.

6-3. LESSON TITLE: GAUGES AND SWITCH PANEL CONTROLS

Action: After this lesson, the student will be familiar with the Gauges and Switch Panel Controls of the Kalmar 53,000-pound RT-240 RTCH.

Condition: Given TM 10-3930-675-10-1, TM 10-3930-675-10-2, and a Kalmar 53,000-pound RT-240 RTCH. Students will be able to monitor and read all Gauges and Switch Panels. Use the Electronic Control System (ECS) Menu Selection Buttons.

Standard: To receive a "GO" for this lesson, the student will correctly answer all check on learning questions.

1. Learning Step/Activity 1. Link lesson plan to individual lesson taught - Gauge and Switch Panel.

Note. View Slide # 37

- **Fuel Gauge:**
 - Located on the left side of dash panel.
 - Indicates the amount of fuel remaining in fuel tank.
 - Measures in increments of quarters of the tank's capacity.
- **Air Vents:**
 - Located on left and right side of dash panel.
 - Provides air outlet for climate control systems.
 - Can be rotated 360 degrees.
- **Hour Meter:**
 - Located to right of the air vent on the left side dash panel.
 - Indicates the total hours of the engine operation.
 - Last digit to the right represents 10th of an operating hour.
 - Used to track/gauge maintenance schedules.
- **12-Volt Utility Plug:**
 - Located to the right of instrument blank cover.
 - Provides 12-volt DC battery power for accessory items.
- **IR Light Switch (IR means Infrared):**
 - It is the 6th rocker switch from the left in the left hand switch cluster on the dash panel.
 - Depress lower part of rocker switch (icon end) down to activate/turn on IR lights.
 - Depress upper part of rocker switch down to deactivate/turn off IR lights.
 - Used when operating under tactical situation using night vision devices.

- **Hazard Warning Light Switch:**
 - Located to the right of the IR light switch
 - Depress icon end of rocker switch down to activate/turn on Hazard Warning lights.
 - Depress upper end of rocker switch to deactivate/turn off Hazard Warning lights.
 - Used to indicate danger/caution for near by personnel or other vehicles.

- **Service Light Switch:**
 - Last switch to the right in left side switch cluster.
 - Depress icon end to activate/turn on service lights.
 - Depress upper end to deactivate service lights.
 - Used for night operations, limited visibility situation and to make the vehicle more visible to other personnel or traffic.

- **Blackout Light Switch:**
 - Located left switch in center switch cluster of dash panel.
 - Depress icon end of switch to activate/turn on blackout drive and blackout marker lights. Also deactivates service lights, container lock indicator on tophandler, joystick control and back-up alarm.
 - Depress upper end of switch to deactivate/turn off blackout drive and blackout lights.
 - Used when operating/self transporting vehicle under tactical conditions.

- **Ether Injection Switch:**
 - Center switch in center switch cluster on dash panel.
 - Depress icon end down momentarily then release.
 - Will return to up position when released.
 - Delivers a measured amount of ether to the engine to assist when performing cold weather starting of the engine.

- **Emergency Pump Switch:** Third/last switch to the right in the center switch cluster on the dash panel. Depress the icon end of switch down and hold until the pump is heard starting. Will return to the up position when released. Starts the emergency pump, which is used to configure the vehicle into the different travel modes.

- **Heater Temperature Control Switch:** Rotate clockwise to increase and counter-clockwise to decrease heater temperature.

- **Air Conditioner Temperature Control Switch:** Rotate clockwise to increase and counterclockwise to decrease the air-conditioner temperature.

- **Cab Air Circulation Control Switch:** Depress the icon end of switch down to turn on cab air circulation control. Depress the top half of switch to turn off cab air circulation.

- **Air Conditioner Control Switch:** Depress the icon end of switch down to turn on air-conditioner. Depress topside of switch to turn air-conditioner off.

- **Fan Switch (Cab Climate Control):** Turn clockwise to increase and counter-clockwise to decrease the heater/A/C fans.

Note. View Slide # 38.

- **Heater and Defroster Selection Switch:** Depress the icon end of switch down to turn on air-conditioner. Depress topside of switch to turn air-conditioner off.
- **Fan Switch.**
- **Arctic Heater Switch.**
- **Boom Work Light Switch.**
- **Tophandler Work Light Switch.**
- **Parking Brake Indicator Light.**
- **Battery Charging Lamp.**

2. Learning Step/Activity 2. Link lesson plan to individual tasks taught - Operator's Controls and Indicators.

Note. View Slide # 39.

a. Steering Column Switches and Controls.

- Twist Lock "Locked" Indicator Light.
- Twist Lock "Alignment" Indicator Light.
- Twist Lock "Unlocked" Indicator Light.
- Turn signal Indicator Light.
- High Beam Indicator Light.
- Diagnostic Connector.
- Electronic Control System Display Screen.
- Warning Indicator Light.
- Ignition switch.
- Accessory Control Lever.
- Roof Window Wiper Switch.
- Rear Window Wiper Switch.
- Electronic Control System (ECS) Menu Selection buttons.

3. Learning Step/Activity 3. Link lesson plan to individual tasks taught - Operator's Controls and Indicators (continued).

Note. View Slide # 40.

b. ECS Menu Selection Buttons.

- Left Arrow Button.
- Right arrow Button.
- Error Message Reset "R" Button.

- Enter Button.
- Value Increase “+” Button.
- Value Decrease “-” Button.

4. Learning Step/Activity 4. Link lesson plan to individual tasks taught - Operator’s Controls and Indicators (continued).

Note. View Slide # 41.

a. Electronic Control System (ECS) Display Screens.

- ECS Icon Screen.
- Operational Screen.
- Engine Monitoring Screen.
- Temperature Screen.
- Service and Maintenance Access Screen.
- Boom Extension Screen.
- Boom Height Screen.
- Boom and Tophandler Lift Angle Screen.

5. Learning Step/Activity 5. Link lesson plan to individual tasks taught - Steering Wheel and Steering Column Controls.

Note. View Slide # 42.

- Steering Wheel. Adjusts fore and aft by way of a release lever located on right hand side of the steering collar.
- Adjustable Steering Column. Adjusts fore and aft by way of a binding screw locate on lower right hand side of the steering column.

6. Learning Step/Activity 6. Link lesson plan to individual tasks taught - Accelerator and Brake Controls.

Note. View Slide # 43.

- Service Brake Pedal. The Service Brake Pedal has two sides. The right side applies the braking action to the machine. The left side allows application of the brakes and the Transmission Disconnect Pedal at the same time.
- Transmission Disconnect Brake Pedal. When depressed allows the operation of the hydraulic controls at elevated engine speeds. It disconnects the engine from the drive train as the Service Brake Pedal holds the machine at a halt.
- Accelerator Pedal. When depressed it increases engine RPMs, providing power to Boom and Tophandler.

7. Learning Step/Activity 7. Link lesson plan to individual tasks taught - Boom and Tophandler Controls.

a. Joystick.

Note. View Slide # 44.

- Override Switch.
- Emergency Stop Button.
- Indicator Red – Button Released.
- Indicator Green – Button Pushed.
- Joystick Position Lever.

Note. View Slide # 45.

b. Twist Lock Indicator Lights.

-
- Located on Boom.
- Normal Operations.
- Located on boom.
- Red Light – Indicates Unlocked.
- Amber Light – Indicates Tophandler is aligned.
- Green Light – Indicates Locked.
- IR Operations.
- One Light – Indicates unlocked.
- Two Lights – Indicates Tophandler is aligned.
- Three Lights – Indicates locked.

8. Learning Step/Activity 8. Link lesson plan to individual tasks taught - Remote Hydraulic Controls.

Note. View Slide # 46.

- Cab Lift/Lower Lever.
- Cab Side Movement Lever.
- Locking Pins Lever.
- Folding Boom Support Lever.
- Shutoff Valve # 5.
- Bogie Wheels Lever.

Note. Conduct a check on learning and summarize the learning activity.

Check on Learning

Determine if the students have learned the material presented by soliciting student questions and explanations. Ask the students the following questions and correct student misunderstandings.

- Q. What is the green light on the twistlocks indicate?
A. Twistlocks are turned to the locked position.
- Q. How do you determine the amount of fuel remaining in the fuel tank?
A. Check the fuel gauge.
- Q. What item is used to assist with the maintenance scheduling?
A. Hour meter.
- Q. How do you advance the Electronic Control System (ECS) screen?
A. Press the left arrow or right arrow keys.
- Q. What items are measured/monitored by the temperature screen of the ECS?
A. Ambient, transmission, and hydraulic systems temperature.
- Q. What component controls movement of the tophandler?
A. Joystick.
- Q. Where are the remote hydraulic controls located on the Kalmar RT-240 RTCH?
A. Left side of machine at the rear of the steps to the cab.

ENABLING LEARNING OBJECTIVE C

Note. Inform the students of the enabling learning objective (ELO) requirements.

6-4. LESSON TITLE: OPERATOR CONTROLS AND INSTRUMENTS

Action: After this lesson, the student will be experienced in the responsibilities of the operators, controls, and instruments. Operational maintenance, safety, and basic knowledge and skills to operate the Kalmar 53,000-pound RT-240 RTCH.

Condition: Given TM 10-3930-675-10-1, TM 10-3930-675-10-2, and a Kalmar 53,000-pound RTCH RT-240. The student will demonstrate the operation and use of the Kalmar RT-240 RTCH Boom and Tophandler Joystick Controls. Rotating, Side Shifting, Lifting, Lowering, Oscillation, and Tilt Angles. Twistlocks and Twistlocks indicator lights. Demonstrate Engine Starting procedures of the RT-240 RTCH cold and hot starts. Demonstrate Shutting Down Engine, apply parking brake, retracting and fully lowering the Boom, placing transmission control lever in neutral, and placing master switch to OFF.

Standard: To receive a "GO" for this lesson, the student will be familiar with the starting/operating/stopping procedures, operation of the boom and tophandler with the Kalmar 53,000-pound RT-240 RTCH.

1. Learning Step/Activity 1. Link lesson plan to individual lesson taught.

Note. Discuss warning in reference to compliance with TM 10-3930-675-10-1 and TM 10-3930-675-10-2.

Note. Preventive maintenance checks and services (PMCS) must be performed daily before operations begin.

Note. The warnings and cautions appearing in your PMCS table should always be observed. Warnings and cautions appear before applicable procedures. You must observe these warnings to prevent serious injury to yourself and others, and cautions to prevent your equipment from being damaged.

a. Before-Operations PMCS. To ensure that the Kalmar RT-240 RTCH is ready for operation at all times, it must be inspected on a regular basis so that defects may be found and corrected before they result in serious damage, equipment failure, or injury to personnel. Table 1, WP 0013 00 in TM 10-3930-675-10-1 and TM 10-3930-675-10-2 contains systematic instructions on inspections, adjustments, and corrections to be performed by the operator/crew to keep your equipment in good operating condition and ready for its primary mission.

b. Operation Under Usual Conditions.

Note. View Slide # 47.

- Place master battery switch to ON.
- Occupy and adjust seat.
- Adjust position of joystick.
- Adjust left and right exterior mirrors and interior rearview mirror as required.
- Adjust steering wheel and column.
- Fasten seat belt.

2. Learning Step/Activity 2. Link lesson plan to individual tasks taught.

a. **Starting Engine.**

- Ensure that the parking brake is applied.
- Place the transmission shift lever to Neutral (N).
- Ensure that accessory switches and controls are in the OFF position.
- Turn ignition switch to ON position. System warning lights will illuminate briefly, and then go out.

CAUTION

DO NOT operate the starter motor for more than 30 seconds at a time. After 30 seconds, allow starter motor to cool for at least two minutes before attempting to start engine again. Excessive heating of starter motor may result in damage or early starter failure.

Note. Start the engine with throttle in the IDLE position. DO NOT press accelerator pedal when starting engine, the computer will control the starting and idling speed.

- b. Increase the engine speed (RPMs) slowly to provide adequate lubrication to the bearings and allow the oil pressure to stabilize.
- c. If cold, start and run engine at idle speed until operating temperature of 160 degrees is reached.
- d. If hot, start and run the engine at idle speed for 3 to 5 minutes before operating with load.

Note. The governed engine speed is 2,100 RPM. If engine is allowed to exceed governed speed, serious engine or transmission damage may result.

3. Learning Step/Activity 3. Link lesson plan to individual tasks taught.

a. Operating Transmission and Driving.

- (1) Monitor fuel gauge and indicators for any signs of abnormal temperatures or pressure.
- (2) Shut down engine at the first sign of a problem.
- (3) Raise the tophandler to the driving position.
- (4) With engine at idle, apply the service brake.
- (5) Select steering mode of operation by first straightening wheels, then pressing desired steering selection switch.

(6) Move transmission control lever to desired direction, FORWARD or REVERSE, and select gear range.

(7) Release the parking brake lever and depress accelerator pedal to control truck speed.

(8) Engage oscillation and tilt locks before driving with load.

4. Learning Step/Activity 4 Link lesson plan to individual tasks taught.

a. Driving Tips.

(1) Check fuel gauge, indicators, and ECS display screen frequently. If indicators show an abnormal reading or warning light comes on, bring the RTCH to a safe stop, shut down engine, and investigate cause.

(2) Avoid over steering. Become familiar with steering characteristics of RTCH before attempting maneuvers in limited space.

(3) Avoid hard braking. Become familiar with the braking characteristics of the RTCH with and without a load.

(4) Field of view. When driving without a load, position the tophandler above your field of view, with the BOOM FULLY RETRACTED.

Note. Before traveling with a load. Center and level position the bottom of the load above your field of view, with the BOOM FULLY RETRACTED. Oscillation and tilt locks must be engaged.

b. Driving Warnings and Cautions.

(1) DO NOT allow riders on the truck. Failure to follow this warning may result in serious injury or death to personnel.

(2) RTCH must not be driven when container load is in fully raised position. RTCH is less stable when traveling with the load in a raised position. Always position the bottom of the load just above the driver's field of view, with the BOOM FULLY RETRACTED. Failure to follow this warning may result in serious injury or death to personnel.

(3) BE ALERT for personnel in area while operating truck. Always check to ensure area is clear of personnel and obstructions before moving. Failure to follow this warning may result in serious injury or death to personnel

c. Kalmar RT-240 RTCH Operations.

(1) It is essential that the operator knows how to safely perform every container handling operation of which the Kalmar RT-240 RTCH is capable.

(2) Perform container handling operations, using the joystick to maneuver the lifting boom, tophandler, and forklift kit.

(3) With the forklift kit installed to the tophandler, the tophandler spreader controls will open and close the fork tines.

(4) The Kalmar RT-240 RTCH Electronic Control Unit (ECU) continuously monitors the boom angle, boom extension, and pressure in the hydraulic lift cylinders. From this data the computer calculates the actual load. This information is compared to the allowed load at the current position. When 100 percent capacity is reached, the system cuts off and will not allow any more movement, except to retract. When the load is moved into a safe operating range, the control of the system is returned to the operator controls (joystick).

d. Operate Parking Brake.

Note. View Slide # 48.

(1) Push the parking brake lever forward to engage the parking brakes at front and rear axles. Raise release lever and pull the lever rearward to release the parking brakes.

(2) A RED indicator light will illuminate on the instrument panel when the parking brake is applied.

(3) A buzzer will sound if the driver attempts to leave the driver's seat without first applying the parking brake.

(4) After one emergency application using parking brake, notify Organizational Maintenance to replace parking brake pads.

(5) Do not apply parking brake when vehicle is moving. Bring to a complete Stop.

Note. Never leave the operator's position without applying the parking brake. Failure to follow this warning may result in death or injury to personnel or damage to equipment.

e. Steering Modes.

(1) The Kalmar RT-240 RTCH can be operated in any of three steering modes (two-wheel, four-wheel, or crab steering) as selected by the steering mode selection switches.

(2) The vehicle must be at a complete stop, with wheels forward and transmission in neutral before switching from one mode of steering to another.

(3) The emergency ground-driven steering pump provides emergency steering. If the engine quits during operation, this pump provides sufficient hydraulic pressure to control the truck until it is brought to a safe stop. This pump is also used for towing.

Note. View Slide # 49.

f. Two-Wheel Steering. Press the two-wheel steering selection switch on the steering column. Front wheels will steer in the direction the steering wheel is turned and the rear wheels will remain in the forward position.

Note. View Slide # 50.

g. Four-Wheel Steering. Press the four-wheel steering selection switch on the steering column. Front wheels will steer in the direction the steering wheel is turned and the rear wheels will steer in the opposite direction. This steering mode allows for an extremely short turning radius. It also enables the rear wheels to follow in the tracks of the front wheels, thereby increasing traction in mud and snow conditions.

Note. View Slide # 51.

h. Crab Steering. Press the crab steering selection switch on the steering column. All wheels will steer in the same direction. This steering mode permits sideways movement for better positioning of the truck during transport and moving the truck within tight quarters.

Note. View Slide # 52.

i. Operate Transmission. Select transmission-operating range control lever location on left side of steering column.

Note. ALWAYS bring RTCH to complete STOP before changing from forward to reverse.

j. Two- and four-Wheel Drive.

Note. View Slide # 53.

(1) A two- and four-wheel drive is controlled by the steering mode that is selected.

(2) When in two-wheel steering, the Electronic Stability Control (ESC) shifts the transmission into two-wheel drive.

(3) When in four-wheel or crab steering, the ESC shifts the transmission into four-wheel drive.

k. Operate Lifting Boom and Tophandler.

(1) The lifting boom and tophandler is an electro-hydraulic operated heavy-duty telescoping boom and spreader assembly.

(2) Designed to lift, move, and stack/unstack 20-foot and 40-foot MILVANS.

(3) The operator's joystick provides complete control of the lifting boom and tophandler during container handling operations.

(4) The boom provides lifting/lowering and extending/retracting operations.

(5) The tophandler or spreader provides for side shifting, rotation, forward/rear tilting, left/right tilting, and load leveling and locking operations.

(6) The tophandler also provides interface capability with a forklift attachment.

(7) During lifting operations, do not exceed maximum lifting capability. The following chart indicates lift capacity in relation to boom extension. Note that as the boom is extended, the lift capacity is reduced.

Note. View Slide # 54.

I. Operate Lifting Boom and Tophandler.

(1) Joystick operation. The buttons and switches on the joystick are used, individually or in conjunction with each other to fully control all BOOM and TOPHANDLER operations.

(2) The decal, located on the cab's right-side window, summarizes all joystick functions.

Note. View Slide # 55.

m. Boom Control Handle (Joystick).

(1) Move control handle forward to lower boom.

(2) Move control handle back to raise boom.

(3) Move control handle right to extend boom.

(4) Move control handle left to retract boom.

Note. View Slide # 56.

n. Tophandler Operational Envelope.

(1) Boom fully extended 16 feet, 11 inches from wheels.

(2) Boom fully retracted 1 foot, 4 inches from wheels.

(3) Boom fully lowered, tophandler is 3 feet, 2 inches from ground.

(4) Boom fully raised and fully extended, tophandler is 34 feet from ground.

Note. View Slide # 57.

o. Multiple Function Trigger.

(1) The multiple function trigger button allows two functions to be performed at the same time or allows one button to perform two tasks.

(2) Multiple Function Trigger is the lower button.

(3) When using the Multiple Function Trigger it must be engaged first.

Note. View Slide # 58.

p. Straight Lift/Lower Controls.

(1) Move control handle back while pressing multiple function trigger button to raise and extend boom.

(2) Move control handle forward while pressing multiple function trigger button to lower and retract boom.

(3) When aligning to MILVAN, press and hold multiple function button and move control handle forward. This will allow tophandler to drop straight down onto MILVAN.

WARNING

WHEN ROTATING TOPHANDLER, IT WILL HIT THE TIRES AND FENDERS WITH BOOM RAISED

Note. View Slide # 59.

q. Tophandler Rotating Positions.

(1) Press left side of rocker switch to rotate load clockwise.

(2) Press right side of rocker switch to rotate load counterclockwise.

Note. View Slide # 60.

r. Tophandler Rotating Positions Kalmar RT-240 V2 RTCH.

Note. View Slide # 61.

s. Container Oscillation Angles.

- (1) Container will oscillate 7 degrees, up or down.
- (2) Press multiple function trigger button and right side of rotation control rocker switch to raise left side of load.
- (3) Press multiple function trigger button and left side of rotation control rocker switch to raise right side of load.

Note. View Slide # 62.

t. Tophandler Shifting Positions.

- (1) Tophandler will shift 15 inches left or right from center.
- (2) Press right button to shift load to the right.
- (3) Press left button to shift load to the left.

Note. View Slide # 63.

u. Tophandler Lift Positions.

- (1) Press multiple function trigger and right button to widen tophandler from 20 feet to 40 feet.
- (2) Press multiple function trigger and right button to open forklift tines, if forklift kit is installed.

Note. Warning container can and will hit the tires and fenders.

Note. View Slide # 64.

v. Container Tilt Angles.

- (1) Tilt control is the upper switch.
- (2) Press top of rocker switch to tilt bottom of load out.
- (3) Press bottom of rocker switch to tilt bottom of load in.

WARNING

NEVER OPERATE THE RTCH OR MOVE THE LOAD NEAR A POWER LINE OR OVERHEAD WIRES. FAILURE TO FOLLOW THIS WARNING MAY RESULT IN INJURY OR DEATH TO PERSONNEL OR DAMAGE TO EQUIPMENT.

Note. View Slide # 65.

w. Positioning Tophandler Over MILVAN.

- (1) Press button to lock twistlocks, securing load.
- (2) Press button to unlock twistlocks, releasing load.

Note. View Slide # 66.

x. Tophandler Positioning.

- (1) Adjust the tophandler spreader width (20 feet to 40 feet) for the container to be lifted.
- (2) Position the truck as close to the container as possible (12 inches to 18 inches).
- (3) Adjust the tophandler to the container by rotating, side shifting or moving the boom as necessary.
- (4) Fully lower the tophandler while aligning the twistlocks with the container locking holes.
- (5) When twistlocks are unlocked, RED indicator light on steering column inside cab and at end of boom will illuminate.
- (6) Single IR light at end of boom will illuminate when operating in blackout mode.
- (7) Press button to lock twistlocks, securing load.
- (8) Press button to unlock twistlocks, releasing load.
- (9) Check that the YELLOW alignment indicator light is ON. This indicates the twistlocks are engaged in all four locking holes of the container.
- (10) Lock the twistlocks.
- (11) Check that the GREEN lock indicator light is on and the RED is OFF.
- (12) Lift the load. When load is lifted, the YELLOW alignment indicator light will go out.

Note. Pressing twistlocks lock/unlock button and override switch at the same time will lock out or disable boom lifting and lowering operation. Twistlocks indicator light will turn off. To reactivate boom, momentarily press twistlocks lock/unlock button and override switch at the same time.

Note. View Slide # 67.

y. Joystick Operation.

- (1) Oscillation lock/unlock button.

- (a) Press to engage lock, securing load position.
- (b) Press to release lock, allowing load to float.
- (c) Button illuminates when lock is engaged. Must be locked before traveling with load.

Note. View Slide # 68.

- (2) Tilt lock/unlock button.
 - (a) Press to engage lock, securing load position.
 - (b) Press to release lock, allowing load to float.
 - (c) Button illuminates when lock is engaged. Must be locked before traveling with load.

Note. View Slide # 69.

z. Container Positioning for Travel.

- (1) Center and level the load.
- (2) Always position the bottom of the load just above the driver's field of view, with the BOOM FULLY RETRACTED.
- (3) Engage oscillation and tilt locks before driving with a load.

Note. View Slide # 70.

aa. Container Positioning. Lifting and centering 40-foot containers same as the 20-foot.

Note. View Slides # 71 and # 72.

bb. Joystick Override Switch.

- (1) *Move control handle forward and left while pressing the override switch to retract and lower the boom in an override condition.*
- (2) Press override switch to activate hydraulic system while engine RPMs are below 600.
- (3) Press override switch to override twistlocks alignment, locked or unlocked signals.
- (4) Pressing twistlocks lock/unlock button and override switch at the same time will lock out or disable boom lifting and lowering operation. Twistlocks indicator light will turn off. To reactivate boom, momentarily press twistlocks lock/unlock button and override switch at the same time.

Note. View Slide # 73.

cc. Joystick Emergency Stop Button.

- (1) Press button to stop all boom and tophandler hydraulic functions.
- (2) Be sure to release emergency stop button when resuming normal operation. If emergency stop button is left activated, error codes may appear on ECS driver's display screen.
- (3) Pull button to release emergency stop button.

Note. View Slide # 74.

dd. Container Reach and Load Range.

- (1) Row One - 53,000 pounds.
- (2) Row Two - 27,500 pounds.
- (3) Three high in each row.

CAUTION

NEVER turn master battery switch to OFF when the engine is running.
Damage to voltage regulator will result.

ee. Shutting Down Engine.

- (1) Apply the parking brake.
- (2) Place transmission control lever in Neutral (N).
- (3) Retract and fully lower boom.
- (4) Allow the engine to run for 1/2 to 1 minute at idle.
- (5) Stop the engine by turning ignition switch to OFF position.
- (6) If the truck will not be used for a period of time, place master battery switch to OFF.

Note. Conduct a check on learning and summarize the learning activity.

Check on Learning

Determine if the students have learned the material presented by soliciting student questions and explanations. Ask the students the following questions and correct student misunderstandings.

- Q. If hot starting the engine, how long do you idle the engine after starting before operating with load?
A. 3 to 5 minutes.
- Q. How do you forward advance or reverse the Electronic Control System (ECS) screen?
A. Press the left arrow or right arrow keys.
- Q. What items are measured/monitored by the temperature screen of the ECS?
A. Ambient, transmission, and hydraulic systems temperature.
- Q. What component controls movement of the tophandler?
A. Joystick.
- Q. Where are the remote hydraulic controls located on the Kalmar RT-240 RTCH?
A. Left side of machine at the rear of the steps to the cab.

ENABLING LEARNING OBJECTIVE D**6-5. LESSON TITLE: PREVENTIVE MAINTENANCE CHECKS AND SERVICES**

INSTRUCTIONAL GUIDANCE: Before presenting this lesson, instructors must thoroughly prepare by studying this lesson and identified reference material. Instructor should use the following slides and other handouts:

- Appendix A (Slides).
- Appendix B (Force Protection Annex).
- Appendix C (60 Rules of Safety for Operating Material Handling Equipment (MHE)) to conduct a safety briefing before operations begin.
- Appendix D (Practical Exercises).
- Appendix E (Handouts and Worksheets).

Note. Instructors must conduct Risk Assessment using DA Form 7566 (Composite Risk Management Worksheet).

MOTIVATOR: Using personal experience or related stories give a brief explanation of why this lesson is important to the student

TERMINAL LEARNING OBJECTIVE: Inform students of the terminal learning objective (TLO) requirements.

Action: After this lesson, the student will be knowledgeable of the responsibilities of the PMCS on the Kalmar 53,000-pound RT-240 RTCH.

Condition: Given TM 10-3930-675-10-1, TM 10-3930-675-10-2, and a Kalmar 53,000-pound RT-240 RTCH, the student will perform preventive maintenance checks and services on the Kalmar RT-240 RTCH to ensure that the Kalmar RT-240 RTCH is ready for operation at all times.

Standard: To receive a "GO" for this lesson, the student will be familiar with the preventive maintenance checks and services of the Kalmar 53,000-pound RT-240 RTCH.

SAFETY REQUIREMENTS:

- Instructor will use Appendix C (60 Rules of Safety for Operating Material Handling Equipment (MHE)) to conduct a safety briefing before operations begin each morning and maintain direct supervision throughout the day.
- Safety will be discussed and practiced throughout this lesson.
- Safety clothing (hard hats, gloves, and steel-toed boots, and hearing protection) will be worn at all times while performing these tasks.
- One Instructor will be with MHE at all times with one student without TA 50. Student will sound warning before movement. Back only with ground guides using 3-point system. Look before backing and keep looking back until stopped. Never back long distances and never use mirrors for backing.

RISK ASSESSMENT LEVEL: Moderate.

ENVIRONMENTAL CONSIDERATIONS: It is the responsibility of all Soldiers and DA civilians to protect the environment from damage. AR 200-1 delineates TRADOC responsibilities to integrate environmental requirements across DOTMLPF and ensure all training procedures, training materials, and training doctrine, to include sound environmental practices and considerations. The Army's environmental standard is to be a national leader in environmental and natural resource stewardship for present and future generations. This training support package meets this standard.

EVALUATION: Inform the Soldiers how, when, and where performance of the TLO will be evaluated. This lesson is examinable during the scheduled performance test.

INSTRUCTIONAL LEAD IN: Transition students to presentation using personal experience or related story explain why this lesson is important to the students.

REVIEW/SUMMARIZE: This lesson supports Army operations doctrine and concepts and discusses the safe operation of the Kalmar RT-240 RTCH.

TESTING REQUIREMENTS: Describe how the student must demonstrate accomplishment of the TLO standard. Refer student to the Student Evaluation Plan.

FEEDBACK REQUIREMENT: Rapid, immediate feedback is essential to effective learning. Schedule and provide feedback on the evaluation and any information to help answer students' questions about the test. Provide remedial training as needed.

TRANSITION TO THE NEXT LESSON: Read your syllabus for the next lesson, location, and study assignment.

INTERMEDIATE LEARNING OBJECTIVE 1

Note. Inform the students of the enabling learning objective (ELO) requirements.

6-6. LESSON TITLE: FAMILIAR WITH PREVENTIVE MAINTENANCE CHECKS AND SERVICES

Action: After this lesson, the student will be familiar with the preventive maintenance checks and services (PMCS) for the Kalmar 53,000-pound RT-240 RTCH.

Conditions: Given TM 10-3930-675-10-1, TM 10-3930-675-10-2, and a Kalmar 53,000-pound RTCH RT-240. Perform the PMCS inspection on the Kalmar RT-240 RTCH to ensure that the Kalmar RT-240 RTCH is ready for operation at all times. Inspections, adjustments, and corrections must be performed by the operator/crew to keep your equipment in good operating condition and ready for its primary mission.

Standard: To receive a "GO" for this lesson, the student will be able to accomplish the PMCS on the Kalmar 53,000-pound RT-240 RTCH.

1. Learning Step/Activity 1. Link lesson plan to individual tasks taught - Preventive Maintenance Checks and Services (PMCS) for the Kalmar RT-240 RTCH.

a. General.

(1) To ensure that the Kalmar RT-240 RTCH is ready for operation at all times, it must be inspected on a regular basis so that defects may be found and corrected before they result in serious damage, equipment failure, or injury to personnel. Table 1 in WP 0013 00 contains systematic instructions on inspections, adjustments, and corrections to be performed by the operator/crew to keep your equipment in good operating condition and ready for its primary mission.

(2) The Warnings and Cautions appearing in your PMCS table should always be observed. Warnings and Cautions appear before applicable procedures. You must observe these Warnings to prevent serious injury to yourself and others, and Cautions to prevent your equipment from being damaged.

(3) PMCS is covered in TM 10-3930-675-10-1, WP 0013 00-1.

Note. View Slide # 75.

b. Explanation of Table Entries.

(1) Item Number (Item No.) Column. Numbers in this column are for reference.

(2) When completing DA Form 2404 (Equipment Inspection and Maintenance Worksheet) or DA Form 5988-E (Equipment Inspection Maintenance Worksheet), include the item number for the check/service indicating a fault.

(3) Item numbers also appear in the order that you must perform checks and services for the interval listed.

Note. View Slide # 76.

c. Interval Column.

- (1) Before procedures must be done immediately before you operate the truck.
- (2) During procedures must be done while you are operating the truck.
- (3) After procedures must be done immediately after you have operated the truck.
- (4) Weekly procedures must be done once each week.
- (5) Monthly procedures must be done once a month.

Note. View Slide # 77.

d. Location, Item to Check or Service Column. This column provides the location and item to be checked or serviced. The item location is underlined.

Note. View Slide # 78.

e. Procedure Column.

(1) This column gives the procedure you must perform to check or service the item listed in the Item to Check/Service column to know if the equipment is ready or available for its intended mission or for operation,

- (2) You must perform the procedure at the time stated in the interval column.

Note. View Slide # 79.

f. Not Fully Mission Capable Column.

(1) Information in this column tells you what faults will keep your equipment from being capable of performing its primary mission.

(2) If you perform check/service procedures that show faults listed in this column, the equipment is not mission-capable.

(3) Follow standard operating procedures for maintaining the equipment or reporting equipment failure.

g. General PMCS Procedures.

- (1) Always perform PMCS in the same order so it gets to be a habit.
- (2) Once you have had some practice, you will spot anything wrong in a hurry.

(3) If the truck does not perform as required, refer to the appropriate troubleshooting procedure in chapter 3.

(4) If anything looks wrong and you cannot fix it, write it on your DA Form 5988-E. If you find something seriously wrong, IMMEDIATELY report it to your supervisor.

(5) Before performing preventive maintenance, read all the checks required for the applicable interval and prepare all the tools you need to make all the checks. You will always need a rag or two.

(6) Keep it clean. Dirt, grease, oil, and debris get in the way and may cover up a serious problem.

(7) Clean as you work and as needed.

(8) Use dry cleaning solvent (item 13, WP 0019 00) on all metal surfaces,

(9) Use detergent (item 3, WP 0019 00) and water when you clean rubber, plastic, and painted surfaces,

(10) Dry Cleaning Solvent P-D-680 Type III.

(a) Dry cleaning solvent P-D-680 Type III is toxic and flammable. Wear protective goggles and gloves and use only in a well-ventilated area.

(b) Avoid contact with skin, eyes, and clothes and do not breathe vapors.

(c) Do not use near open flame or excessive heat. The solvent's flash point is 200° F (94° C).

(d) If you become dizzy while using dry cleaning solvent, get fresh air immediately and get medical help.

(e) If solvent contacts eyes, wash your eyes and get medical aid immediately.

(11) Rust and Corrosion. Check metal parts for rust and corrosion. If any bare metal or corrosion exists, clean and apply a light coat of lubricating oil (item 10, WP 0019 00). Report it to your supervisor.

(12) Bolts, Nuts, and Screws. Check bolts, nuts, and screws for obvious looseness, missing, bent, or broken condition.

(13) You cannot try all bolts with a tool, but look for chipped paint, bare metal, or rust around bolt heads. If you find one you think is loose, tighten it.

(14) Welds. Look for loose or chipped paint, rust, or gaps where parts are welded together.

(15) If you find a bad weld, report it to your supervisor.

(16) Electric Wires and Connectors. Look for cracked or broken insulation, bare wires, and loose or broken connectors.

(17) Tighten loose connectors and ensure that the wires are in good condition.

(18) Hoses and Fluid Lines.

- (a) Look for wear, damage, and signs of leaks.
- (b) Ensure that clamps and fittings are tight.
- (c) Wet spots indicate leaks, but a stain around a fitting or connector can also mean a leak.
- (d) If a leak comes from a loose fitting or connector, tighten it.
- (e) If something is broken or worn out, report it to your supervisor.

(19) Fluid Leakage.

(a) It is necessary for you to know how fluid leakage affects the status of the Kalmar RT-240 RTCH.

(b) The following are definitions of the types/classes of leakage you need to know to be able to determine the status of the Kalmar RT-240 RTCH.

(c) Learn and be familiar with them, and remember when in doubt, notify your supervisor.

h. Leakage Definitions.

- (1) Class I Leakage indicated by wetness or discoloration, but not great enough to form drops.
- (2) Class II Leakage great enough to form drops, but not enough to cause drops to drip from the item being checked/inspected.
- (3) Class III Leakage great enough to form drops that fall from the item being checked/inspected.
- (4) Operation is allowable with Class I and Class II leakage.
- (5) When operating with Class I or Class II leaks, check fluid levels more frequently.
- (6) Class III leaks must be reported immediately to your supervisor.
- (7) Failure to do this will result in damage to vehicle and/or components.
- (8) When in doubt, notify your supervisor.

Note. View Slide # 80.

i. PMCS for Kalmar RT-240 RTCH - # 5 Before – Boom Support Locking Pin. Ensure that boom support locking pin is present and extension is locked by retaining pin in extended position. Boom support locking pin is missing; extension is not locked in extended position or is damaged.

Note. View Slides # 81.

j. PMCS for Kalmar RT-240 RTCH - # 9 Before – Hydraulic Reservoir and Sight Gauge.

Note. Check for damage and leaks.

(a) Boom must be fully lowered and retracted and truck on level ground before checking hydraulic oil level in reservoir. Engine should be stopped at least five minutes.

(b) If hydraulic oil is visible in sight gauge, level is okay. If level is low, add oil in accordance with instructions in LO 10-3930-675-12.

Note. View Slides # 82.

k. PMCS for Kalmar RT-240 RTCH - # 12 Before – Twistlocks. Visually check all twistlocks, hydraulic cylinders, electrical wiring, and switches for signs of damage.

Note. View Slides # 83.

l. PMCS for Kalmar RT-240 RTCH - # 13 Before – Engine Oil Level. Check engine oil level on dipstick. Maintain oil level within cross hatched area at end of dipstick. If level is low, add oil in accordance with LO 10-3930-675-12.

(1) Wait 10 minutes after shutting down engine to allow oil to drain into crankcase.

(2) To ensure an accurate reading, vehicle must be parked on level ground.

(3) Start engine. Verify that all indicator and warning lights operate properly on ECS display screen.

(4) Check operating lights (such as brake lights, turn signals, and so on).

(5) With RTCH fully warmed up, monitor indicators and warning lights on ECS display screen. Check that engine oil pressure and temperature and transmission and hydraulic system and engine coolant temperatures register within normal ranges:

(a) Engine oil pressure—15 psi to 35 psi (103 kPa to 241 kPa).

(b) Engine oil temperature—195° F to 240° F (91° C to 116° C).

(c) Transmission temperature—175° F to 220° F (79° C to 104° C).

(d) Hydraulic oil temperature—below 160° F (71° C).

- (e) Coolant temperature—175° F to 210° F (79° C to 99° C).
- (f) Ensure alternator charging lamp is not lit.

Note. View Slide # 84.

m. PMCS for Kalmar RT-240 RTCH - Check Coolant Level in Expansion Tank.

- (1) DO NOT service cooling system unless engine has been allowed to cool down. DO NOT remove radiator cap.
- (2) Add coolant only to expansion tank. This is a pressurized cooling system and escaping steam or hot coolant will cause serious burns.
- (3) Wear effective eye, glove, and skin protection when handling coolants. Failure to do so may cause injury.
- (4) Level should be between the MIN and MAX lines on tank. Add coolant as required.

Note. View Slides # 85.

n. PMCS for Kalmar RT-240 RTCH - # 35 After – Transmission Oil Level.

- (1) With engine idling, transmission selector lever in N, parking brake set, and engine at operating temperature (coolant temperature of 180° F [82° C] minimum), remove transmission dipstick.
- (2) Level as indicated on dipstick should be maintained within two indicator marks at end of dipstick.
- (3) If level is low, add transmission fluid in accordance with LO 10-3930-675-12.

Note. View Slides # 86.

o. PMCS for Kalmar RT-240 RTCH - # 35 After – Transmission Oil Level (continued).

- (1) Transmission oil level gauge.
- (2) Transmission oil fill.

Note. Conduct a check on learning and summarize the learning activity.

2. Learning Step/Activity 2. Link lesson plan to individual tasks taught - Weekly, Monthly Preventive Maintenance Checks and Services (PMCS) for the Kalmar RT-240 RTCH.

Note. View Slide # 87.

a. PMCS for Kalmar RT-240 RTCH - # 46 Weekly – Fuel/Water Separator.

(1) Weekly Fuel/Water Separator.

(2) Turn drain knob counterclockwise and drain all water from fuel/water separator.

Note. View Slide # 88.

b. PMCS for Kalmar RT-240 RTCH – Engine Air Cleaner Servicing. Dust vent may be squeezed 2 to 3 times while engine is running to evacuate dust from air cleaner.

Note. Perform service only if indicator shows red.

Note. View Slide # 89.

c. Engine Air Cleaner Servicing. Open six spring clips and remove cover from end of engine air cleaner.

Note. View Slides # 90 and # 91.

d. Filter Element. Remove primary filter element from air cleaner.

(1) Remove secondary filter element from air cleaner.

(2) Using rags, wipe interior of air cleaner free of dust and dirt.

(3) Clean filters with air.

e. Monthly PMCS for Kalmar RT-240 RTCH.

(1) Monthly cab and boom support.

(2) Place cab and boom support in transport position (WP 0007 00) to check for proper operation.

Note. Conduct a check on learning and summarize the learning activity.

Check on Learning

Determine if the students have learned the material presented by soliciting student questions and explanations. Ask the students the following questions and correct student misunderstandings.

- Q. What information can be found in the Procedure Column?
A. Procedures you must perform to check or service the item.
- Q. Is the Kalmar RT-240 RTCH fully operation with a class II leak in the transmission?
A. Yes, the fluid should be check more frequently.
- Q. Describe a class II leak?
A. Leakage great enough to form drops but not enough to cause drops to drip.
- Q. When should the indicators and warning lights be monitored and recorded?
A. With the Kalmar RT-240 RTCH fully warmed up.

INTERMEDIATE LEARNING OBJECTIVE 2

Note. Inform the students of the enabling learning objective (ELO) requirements.

6-7. LESSON TITLE: RELIEVING HYDRAULIC SYSTEM PRESSURE AND CAGING AND UNCAGING THE PARKING BRAKE

Action: After this lesson, the student will be familiar with relieving hydraulic system pressure and caging and uncaging the parking brake for the Kalmar 53,000-pound RT-240 RTCH.

Conditions: Given TM 10-3930-675-10-1, TM 10-3930-675-10-2, and a Kalmar 53,000-pound RT-240 RTCH. Perform inspections and maintenance on the RT-240 RTCH to ensure that the Kalmar RT-240 RTCH is ready for operation at all times. Inspections, adjustments, must be made to the hydraulic system and caging and uncaging the parking brake must be performed by the operator/crew to keep your equipment in good operating condition and ready for its primary mission.

Standard: To receive a "GO" for this lesson, the student will be able to accomplish the inspections adjustments to the hydraulic system and cage and uncage the parking brake on the Kalmar 53,000-pound RT-240 RTCH.

1. Learning Step/Activity 1. Link lesson plan to individual tasks taught - Introduction to Crew/Operator Maintenance for the Kalmar RT-240 RTCH.

Note. View Slide #92

a. Relieving Hydraulic System Pressure.

Note. DO NOT disconnect or remove any hydraulic system line or fitting unless hydraulic system pressure has been relieved. Tighten all connections before applying pressure.

(1) DO NOT disconnect or remove any hydraulic system line or fitting unless hydraulic system pressure has been relieved. Tighten all connections before applying pressure.

(2) Escaping hydraulic fluid under pressure can penetrate the skin causing serious injury.

(3) Search for leaks with a piece of cardboard. Protect hands and body from high-pressure fluids. If an accident occurs, see a doctor immediately. Any fluid injected into the skin must be surgically removed. Within a few hours or gangrene may result.

(4) During operation of the RTCH, hydraulic pressure is generated by hydraulic pumps to operate the following:

(a) Lifting boom.

(b) Tophandler.

(c) Service brakes.

- (d) Parking brakes.
- (e) Steering system.
- (f) Bogie wheel assembly hydraulic cylinders.
- (g) Cab movement hydraulic cylinders.

2. Learning Step/Activity 2. Link lesson plan to individual tasks taught - Relieving Hydraulic System Pressure on the Kalmar RT-240 RTCH.

- a. Both brake and steering systems have pressurized accumulators that provide adequate stored energy to operate in the event of engine shutdown.
- b. To safely perform maintenance on all hydraulic systems, hydraulic pressure must first be relieved.
- c. To relieve hydraulic pressure in ALL systems, perform the following:
 - (1) Lower and fully retract boom.
 - (2) Shut down engine.
 - (3) When performing steering or brake hydraulic system maintenance, leave evacuation valves open until maintenance action is completed. Then close valves before starting engine to pressurize system.
 - (4) To release pressure in steering hydraulic system, open steering accumulator evacuation valve behind cab.
 - (5) Allow pressure to release, approximately 15 seconds.
 - (6) It is now safe to perform maintenance on steering system.

Note. View Slide # 92.

- (7) To release pressure in brake hydraulic system, open two brake accumulator evacuation valves behind cab.
- (8) Allow pressure to release, approximately 15 seconds. It is now safe to perform maintenance on brake system.

Note. View Slide # 93.

- (9) To release pressure in boom hydraulic system (boom extension and lift cylinders, hoses, pipes, and valves), open float control valve and emergency control valve on each locking valve at base of

each lift cylinder. Leave valves open until maintenance action is completed, then close valves before starting engine to pressurize system.

Note. View Slide # 94.

(10) When disconnecting hydraulic lines from boom folding cylinders, additional precautions are required due to residual pressure in lines:

- (a) Wear eye protection.
- (b) Have a rag handy and slowly disconnect hydraulic lines.

3. Learning Step/Activity 3. Link lesson plan to individual tasks taught - Caging and Uncaging Parking Brake on the RTCH 240.

Note. View Slide # 95.

a. Caging. In order to tow a disabled RTCH, the caging and uncaging of the parking brake must be performed at front and rear parking brake.

Note. Caging and uncaging procedures at front and rear parking brake are the same.

- (1) Remove cover.
- (2) A strap wrench may be required to remove cover.

Note. View Slide # 96.

- (3) Loosen jam nut.
- (4) Loosen adjusting screw until brake disk pad moves freely.
- (5) Hand tighten jam nut and reinstall cover.

Note. The RTCH can now be safety towed.

b. Uncaging.

- (1) Remove cover.
- (2) Loosen jam nut.
- (3) Tighten adjusting screw until brake disk pad contacts rotor.

-
- (4) Retighten jam nut.
 - (5) With parking brake released in cab, ensure there is a gap between brake disk pad and rotor.
 - (6) Loosen jam nut. Tighten adjusting screw until contact is made between brake disk pad and rotor, then back off adjusting screw 4/5th of a turn. Gap should be 1 to 2 mm (0.04 to 0.08 inches).
 - (7) Tighten jam nut.
 - (8) Replace covers O-ring only if damaged.
 - (9) Install cover hand tight.

Note. Conduct a check on learning and summarize the learning activity.

Check on Learning

Determine if the students have learned the material presented by soliciting student questions and explanations. Ask the students the following questions and correct student misunderstandings.

- Q. How should you search for hydraulic leaks?
A. Search for leaks with a piece of cardboard.
- Q. Is the Kalmar RT-240 RTCH fully operation with a class II leak in the hydraulic systems?
A. Yes the fluid should be check more frequently.
- Q. Are the caging and uncaging procedures for front and rear parking brake the same?
A. Yes.

INTERMEDIATE LEARNING OBJECTIVE 3

Note. Inform the students of the enabling learning objective (ELO) requirements.

6-8. LESSON TITLE: LUBRICATION ORDER AND READING ON-BOARD COMPUTER

Action: After this lesson, the student will be familiar with Lubrication Order and Reading the On-Board Computer. Error Code Display screen of the Kalmar 53,000-pound RT-240 RTCH.

Conditions: Given TM 10-3930-675-10-1, TM 10-3930-675-10-2, and a Kalmar 53,000-pound RT-240 RTCH. Perform lubrication and read the on-board computer error code display screen on the Kalmar RT-240 RTCH to ensure that the RT-240 is ready for operation at all times. The operator/crew must make lubrication to the RT-240 system and read the error code display screen to keep your equipment in safe operating condition and ready for its primary mission.

Standard: To receive a "GO" for this lesson, the student will be able to accomplish the lubrication and reading the on-board computer error code display screen on the Kalmar 53,000-pound RT-240 RTCH.

1. Learning Step/Activity 1. Link lesson plan to individual tasks taught - Lubrication Order and On-Board Computer Error Code Display.

a. Lubrication Order.

(1) In addition to PMCS, the operator is responsible for the lubrication and care of the Kalmar RT-240 RTCH.

(2) This lubrication order (LO) is for operator/crew and organizational maintenance. The lowest level of maintenance authorized to lubricate a point is indicated on the lubrication chart by either operator/crew (C) or organizational maintenance (O). Operator/crew may lubricate points authorized for organizational maintenance.

b. Lubrication Instructions.

(1) Keep all lubricants in a closed container and store in a clean, dry place away from extreme heat.

(2) Keep container covers clean and do not allow dust, dirt, or other foreign material to mix with lubricants.

(3) Clean area around lubrication points with dry cleaning solvent or equivalent before lubricating equipment.

(4) Keep all external parts of equipment not requiring lubrication free of lubricants.

(5) After lubrication, wipe off excess lubricant to prevent accumulation of foreign matter.

(6) Lubrication points indicated with dashed leader lines are lubricated on both sides of the vehicle.

Note. DO NOT lubricate boom and tophandler wear plates.

Note. View Slide # 97.

c. Kalmar RT-240 RTCH Lubricant Intervals.

- (1) One of four charts for operator/crew lubrication order.
- (2) Operator/crew lubrication points are indicated by a (C).
- (3) Intervals, D – Daily, W – Weekly, HR – Hours, OC – On Condition.

d. Lubricant Components.

- (1) MIL-PRF-2104: Lubricating Oil, Tactical for Engine use 15/40 weight (for hydraulic use 10 weight).
- (2) MIL-L-2105: Lubricating Oil, Gear, Multipurpose.
- (3) MIL-G-10924: Grease, Automotive and Artillery All Temperatures.
- (4) MILA46153: Permanent, Ethylene Glycol, Inhibited, Heavy-Duty.

Note. Conduct a check on learning and summarize the learning activity.

2. Learning Step/Activity 2. Link lesson plan to individual tasks taught.

Note. View Slide # 98.

a. On-board Computer Error Code Display and Error Codes. The RTCH has an extensive on-board diagnostic capability that enables the user to isolate faults based on error codes. This diagnostic capability, when used in conjunction with traditional troubleshooting techniques, enables the user to fault isolate most malfunctions that will occur on the RTCH.

Note. View Slide # 99.

b. Error Code Display Screen.

(1) Common malfunctions which may occur will be detected by one of the six computers on-board and displayed on driver's Electronic Control System (ECS) screen.

(2) When an error code appears on driver's display screen during operation, the operator must know how to read and what actions should be taken.

Note. View Slide # 100.

c. Error Code Display.

(1) These error codes are visible to both the driver and the maintainer and address very specific equipment conditions on the vehicle.

(2) This error code listing also addresses required driver actions based on the category and type of error identified.

(3) There are three kinds of information in the Electronic Control System display.

(4) Icons in the left lower corner of the display describe what the driver actions are.

Note. View Slides # 101 and # 102.

d. Driver Actions.

(1) STOP VEHICLE IMMEDIATELY in a safe way. Can be a safety issue. Machine performance may be restricted. Read operator's manual for instructions. Contact maintenance personnel.

(2) WARNING - DEGRADED OPERATION, Stop vehicle in a safe way. Read operator's manual for instructions. Contact maintenance personnel. Confirm that error message is acknowledged by pressing RESET button. Error will appear every three minutes as long as error is active. It can be reset every time it shows.

(3) INFORMATION/MAINTENANCE action is needed. Error code shows once when vehicle starts up. Acknowledge error message by pressing RESET. These error codes may be deactivated for driver, so that they only show when maintenance personnel activate them.

Note. View Slide # 103.

e. Type of Fault. Icons in the center of the display identify the type of fault. There are five fault types used.

Note. View Slides # 104.

f. Function or Vehicle Fault Icons. Function or Vehicle Fault Icons in the right of the display identify what function or vehicle system the fault is related to. This table lists the various functions or vehicle systems used in the display.

Note. View Slide # 105.

g. Error Code Number. Error Code Number in the upper left corner of the display is the TM 10-3930-675-10-1 or TM 10-3930-675-10-2 operator's manual error code category number.

Note. View Slide # 106.

h. Error Derate Error Codes.

i. ECS Display Screen. Whenever ECS display screen indicates a fault code, shut down engine, then restart engine. If fault code persists, maintenance should be notified.

j. Error Code. When an error codes appears follow on screen display actions before continuing operations of Kalmar RT-240 RTCH.

k. On-board Diagnostics. Even though the RTCH has on-board diagnostics, not all malfunctions will produce error codes. It is not possible to display all malfunctions that may occur.

Note. Conduct a check on learning and summarize the learning activity.

Check on Learning

Determine if the students have learned the material presented by soliciting student questions and explanations. Ask the students the following questions and correct student misunderstandings.

Q. What type of lubricates should be used on boom and tophandler wear plates?

A. None.

Q. What doses ECS stand for?

A. Electronic Control System.

Q. What is the first thing that should be done whenever ECS display screen indicates a fault code?

A. Shut down engine, then restart engine. If fault code persists, maintenance should be notified.

This page intentionally left blank.

CHAPTER 7

LESSON OUTLINE FOR LIFTING AND TRANSPORTING CONTAINERS WITH THE KALMAR RT-240 ROUGH TERRAIN CONTAINER HANDLER

7-1. LESSON TITLE: LIFTING AND TRANSPORTING CONTAINERS**INSTRUCTIONAL GUIDANCE:**

- Before presenting this lesson, instructors must thoroughly prepare by studying this lesson and identify reference material. Instructors must ensure that facilities, equipment, and training materials are ready prior to class start time.
- Instructor should use Appendix D (Practical Exercises).
- Instructors must conduct Risk Assessment using DA Form 7566 (Composite Risk Management Worksheet).

ADDITIONAL COMMENTS AND INFORMATION:

- Recommended instructional time is 34 hours (2.0 Conference and 32.0 Practical Exercise on Lifting and Transporting Containers).
- Instructor will use Appendix B (Force Protection Annex) and Appendix C (60 Rules of Safety for Operating Material Handling Equipment (MHE)) to conduct a safety briefing before operations begin.

MOTIVATOR: Using personal experience or related story, give a brief explanation of why this lesson is important to the student

TERMINAL LEARNING OBJECTIVE: Inform students of the terminal learning objective (TLO) requirements.

Action: After this lesson, the student will be knowledgeable of the responsibilities of the lifting and transporting containers with the Kalmar 53,000-pound RT-240 RTCH.

Condition: Given TM 10-3930-675-10-1, TM 10-3930-675-10-2, and a Kalmar 53,000-pound RT-240 RTCH. The student will demonstrate the knowledge of picking up and traveling with a loaded container with the Kalmar 53,000-pound RT-240 RTCH and be familiar with the safety and warnings concerning the container operation of the Kalmar 53,000-pound RT-240 RTCH.

Standard: To receive a "GO" for this lesson, the student will demonstrate the knowledge of picking up and traveling with a loaded container with the Kalmar 53,000-pound RT-240 RTCH and the student must correctly answer all check on learning questions.

SAFETY REQUIREMENTS:

- Instructor will use Appendix C (60 Rules of Safety for Operating Material Handling Equipment (MHE)) to conduct a safety briefing before operations begin each morning and maintain direct supervision though out the day.
- Safety will be discussed and practiced throughout this lesson.

- Safety clothing (hard hats, gloves, and steel toed boots, hearing protection) will be worn at all times while performing these tasks.
- One Instructor will be with MHE at all times with one student without TA 50. Student will sound warning before movement. Back only with ground guides using 3-point system. Look before backing and keep looking back until stopped. Never back long distances and never use mirrors for backing.

RISK ASSESSMENT LEVEL: Moderate.

ENVIRONMENTAL CONSIDERATIONS: It is the responsibility of all Soldiers and DA civilians to protect the environment from damage. AR 200-1 delineates TRADOC responsibilities to integrate environmental requirements across DOTMLPF and ensure all training procedures, training materials, and training doctrine, to include sound environmental practices and considerations. The Army's environmental standard is to be a national leader in environmental and natural resource stewardship for present and future generations. This training support package meets this standard.

EVALUATION: Inform the Soldiers how, when, and where performance of the TLO will be evaluated.

INSTRUCTIONAL LEAD IN: Transition students to presentation using personal experience or related story explain why this lesson is important to the students. Instructors should use the following slides from Appendix A:

- Slide #107 through Slide #122 for ELO A (Familiarization With Lifting and Transporting Containers).
- Slide #123 through Slide #133 for ELO B (Off-Loading/Stacking Containers).

ENABLING LEARNING OBJECTIVE A**7-2. LESSON TITLE: FAMILIARIZATION WITH LIFTING AND TRANSPORTING CONTAINERS**

Action: After this lesson, the student will be familiar with the lifting and transporting containers with the Kalmar 53,000-pound RT-240 RTCH.

Condition: Given TM 10-3930-675-10-1, TM 10-3930-675-10-2, and a Kalmar 53,000-pound RT-240 RTCH. After this lesson, the student will be familiar with the picking up and traveling with a loaded container with the Kalmar 53,000-pound RT-240 RTCH.

Standard: To receive a "GO" for this lesson, the student will be familiar with the, picking up and traveling with a loaded container operation of the Kalmar 53,000-pound RT-240 RTCH and the student must correctly answer all check on learning questions.

1. Learning Step/Activity 1. Link lesson plan to individual tasks taught - Lift and Transporting Containers With the Kalmar RT-240 RTCH.

Note. View Slides # 107, # 108, # 109, and # 110.

a. Approaching MILVAN/Container for Pick Up.

- (1) Raise tophandler high enough to clear top of the MILVAN/container and approach slowly.
- (2) There is two ways to align on a MILVAN/container for pick up.
- (3) Pick out a center rib on MILVAN/container.
- (4) Align white line on the tophandler with rib on MILVAN/container, move forward slowly, keeping aligned.
- (5) Using center rib on MILVAN/container align center of valve guard between hydraulic hose with center rib.
- (6) Move RTCH forward until wheels are approximately 12 inches to 18 inches from MILVAN/container.
- (7) If using headlight guard, approximately 20 inches.
- (8) Apply parking brake.
- (9) Place transmission lever in neutral.

Note. Transmission disconnect should never be used during pick up.

Note. View Slide # 111.

b. Transmission Disconnect.

- (1) Transmission disconnect brake pedal location.

- (2) Depress to release transmission internal clutch.
- (3) This allows the operator to increase engine RPM, thereby accelerating hydraulic functions.
- (4) Transmission disconnect should be used for a short time only.

Note. Conduct a check on learning and summarize the learning activity.

2. Learning Step/Activity 2. Link lesson plan to individual tasks taught.

Note. View Slide # 112.

a. Joystick Control Buttons.

(1) Tilt and oscillation should be locked to secure the tophandler movement during hook up of MILVAN/container.

- (2) Buttons illuminates when lock is engaged.

Note. View Slide # 113.

b. Tilt Control.

(1) Use tilt control switch to level fwd and aft twistlocks with top of MILVAN/container.

- (2) Top of switch tilts out.

- (3) Bottom of switch tilts in.

Note. View Slide # 114.

c. Oscillation.

(1) Use oscillating controls to adjust right and left twistlocks the same distance from MILVAN/container.

- (2) Press multiple function trigger and rotation control rocker switch for oscillation movement.

Note. View Slide # 115.

d. Boom Control.

(1) Use joystick to align twistlocks with the container locking holes by extending or retracting boom.

(2) Raise or lower boom until twistlocks are approximately 4 inches x 6 inches from MILVAN/container.

Note. View Slide # 116.

e. Rotation Control.

(1) Rotate tophandler to align twistlocks with the container locking holes.

(2) Press left side of rocker switch to rotate load clockwise.

(3) Press right side of rocker switch to rotate load counterclockwise.

Note. View Slide # 117.

f. Sideshift.

(1) Side shift tophandler left or right to align twistlocks with the container locking holes.

(2) Side shift should be after rotation side shift gives you a long and short side of the tophandler, making rotation alignment harder.

Note. View Slide # 118.

g. Lowering Tophandler.

(1) Move joystick forward.

(2) While pressing multiple function trigger button to lower twistlocks into the container locking holes.

Note. View Slide # 119.

h. Yellow Alignment Light.

(1) Check that the yellow alignment indicator light is on.

(2) This indicates that all four twistlocks are engaged in the locking holes of the container.

Note. View Slide # 120.

i. Green Indicator Light.

(1) After yellow light comes on press and hold twistlocks button until green light comes on, this will lock and secure the load.

- (2) When load is lifted the yellow alignment indicator light will go out.
- (3) Oscillation and tilt locks should be disengaged before rising of the load.

Note. View Slide # 121.

j. Lifting the Load.

(1) To raise the load move the joystick back while pressing the multiple function trigger button to raise and extend boom.

(2) This will reduce the chances of the container hitting the wheels.

(3) After the bottom of container is clear of the fenders, release the multiple function trigger and continue to raise boom until the bottom of the load is just above the driver's field of view, on Kalmar RT-240 V2 it must be raised to 340 inches and fully retracted or the maximum traveling speed forward will decrease to 7 mph.

k. Drag Restriction Lockout Kalmar RT-240 V2: If the tophandler is engaged into the MILVAN and it is not lifted off the ground. The transmission will lock out in neutral. Lifting the MILVAN off the ground will allow the transmission to go in gear.

l. Maximum Lifting Capability.

(1) Just after the yellow light goes out and the load is clear of the ground. Check the electronic control system screen making sure the lifting capacity has not been exceeded.

(2) If the weight capacity has been exceeded the system will cut off and will not allow any more movement, except to retract.

(3) This is where the 12 inches to 18 inches is necessary to allow room to retract.

(4) When the load is into a safe operating range, control of the system is returned to the operator.

m. Over Ride Switch.

(1) The over ride switch can be used to lower a load in an "overload protection system lockout."

(2) Operate the twistlocks without a MILVAN attached.

Note. View Slide # 122.

n. Traveling With Load.

(1) Before traveling with a load (center and level the load).

(2) Position the bottom of the load just above your field of view.

(3) With the boom fully retracted.

(4) Oscillation and tilt locks must be engaged (lights on).

o. Travel Speed Restriction Kalmar RT-240 V2. If the boom is not in the proper carry position with or without a MILVAN, the vehicle speed will decelerate down to 7 mph. When the boom is positioned to the proper carry position, the vehicle will travel at 15 mph maximum.

Note. 7 mph is the maximum speed at any boom position in reverse.

(1) With load 340 inches high and fully retracted.

(2) Without load 240 inches high and fully retracted.

p. Safe Side Slope Driving.

(1) The safest practice for driving on a slope with a MILVAN in the proper carry position is a slope of 7 percent grade or less and at no more than 4 mph.

(2) Heavy end up hill if possible, side shift slightly to the up hill if heavy end must be down hill.

(3) Do not oscillate, oscillating up or down will put more weight down hill.

q. Load Capacity.

(1) Maximum Lifting Capacity:

(a) First Stacking Row 53,000 pounds (26.5 S-TON).

(b) Second Stacking Row 27,500 pounds (13.75 S-TON).

(c) Maximum Lift Height 33 feet (396 inches).

(d) Maximum Forward Reach (Boom Level) 20.6 feet (248 inches).

(2) Lifting empty 20-foot MILVAN the electronic control system screen will read approximately like this one.

r. Road Capacity Chart.

(1) The Load Chart is designed to assist the operator in making safe lifts. The boom length is in relation to the load weight limits actually reflect the center of gravity of the machine.

(2) To the center of gravity of the load.

s. Lowering Container.

(1) To lower a container, extend the boom until load clears the wheels approximately 12 inches to 18 inches.

(2) Release tilt and oscillation lock allowing load to float.

(3) Move joystick forward while pressing multiple function button to allow the load to lower and retract this should maintain the 12 inches to 18 inches from wheels.

(4) Lower container until all four corners touches the ground at the same time.

(5) Make necessary adjustments allowing all four corners to touch the ground at the same time.

(6) This will allow a smooth release of the tophandler when the tophandler is raised from the MILVAN.

Note. Conduct a check on learning and summarize the learning activity.

Check on Learning

Determine if the students have learned the material presented by soliciting student questions and explanations. Ask the students the following questions and correct student misunderstandings.

Q. How close should the wheels be to the MILVAN/container during pick up?

A. Approximately 12 inches to 18 inches from MILVAN/container.

Q. Should the tilt and oscillation be locked or unlocked during pick up?

A. Locked to secure the tophandler movement during hook up of MILVAN/container.

Q. When raising the load off the ground what are the joystick functions?

A. To raise the load move the joystick back while pressing the multiple function trigger button to raise and extend boom.

Q. When traveling with a load, how is the container positioned?

A. Center and level, Position the bottom of the load just above your field of view, boom fully retracted, and oscillation and tilt locks must be engaged (lights on).

ENABLING LEARNING OBJECTIVE B

Note. Inform the students of the enabling learning objective (ELO) requirements.

7-3. LESSON TITLE: OFF-LOADING/STACKING CONTAINERS

Action: After this lesson, the student will be knowledgeable of the responsibilities of off-loading/stacking containers with the Kalmar RT-240 RTCH and with the safety and warnings concerning the operation of the Kalmar 53,000-pound RT-240 RTCH.

Condition: Given TM 10-3930-675-10-1, TM 10-3930-675-10-2, and a Kalmar 53,000-pound RT-240 RTCH. The student will demonstrate the use of off-loading/stacking containers 2 and 3 high, picking up containers at an angle, and picking up containers from the longitudinal position with the Kalmar RT-240 RTCH and with safety concerning the operation.

Standard: To receive a "GO" for this lesson, the student will be familiar with off-loading/stacking containers with the Kalmar RT-240 RTCH and the student must correctly answer all check on learning questions.

1. Learning Step/Activity 1. Link lesson plan to individual tasks taught - Off-loading/Stacking Containers With the Kalmar RT-240 RTCH.

Note. View Slide # 123.

a. Stacking Containers Two High.

(1) Same as one high except that it is important that all four corners touch at the same time and it must be even and straight with tier one MILVAN/container.

(2) The multiple function button should be used when releasing and raising tophandler from the MILVAN/container.

(3) This will allow a smooth release of the tophandler when the tophandler is raised from the MILVAN/container.

Note. View Slide # 124.

b. Stacking Containers Three High.

(1) Same as two high, it is VERY IMPORTANT that all four corners touch at the same time and it MUST be even and straight with lower tiers.

(2) The multiple function button MUST be used when releasing and raising tophandler from the MILVAN/container.

(3) This will allow a smooth release of the tophandler when the tophandler is raised from the MILVAN/container.

Note. View Slide # 125.

c. Picking Up Container From Tier 3.

(1) Picking up a container from 3 high is same as one or two high, except that the multiple function button must be used.

(2) A ground guide should be used; the operator has limited visibility of the tophandler.

(3) The boom must be lowered and retracted MILVAN/container put in travel mode before the RTCH can be moved.

Note. View Slide # 126.

d. Row Two Containers.

(1) All tiers of row two containers have a weight limit of 27,500.

(2) Row one containers should be one tier less in high than row two this will allow safer and better visibility of row two a ground guide should be used when working row two containers.

e. Check On Learning. Conduct a check on learning and summarize the learning activity.

2. Learning Step/Activity 2. Link lesson plan to individual tasks taught - Pick-up and Loading Containers Longitudinal and at an Angle With the Kalmar RT-240 RTCH.

Note. View Slides # 127 thru # 131.

a. Picking up Container Longitudinal.

(1) One high only 20-foot or 40-foot tophandler will hit boom.

(2) A 40-foot must be empty.

(3) Stop RTCH before approaching MILVAN/container, Select Crab Steering.

(4) Extend boom.

(5) Rotate tophandler 90 degrees clockwise to longitudinal position.

(6) Raise tophandler high enough to clear top of MILVAN/container and approach slowly.

(7) Center and level tophandler with MILVAN/container while approaching.

(8) Use Crab Steering to line the tophandler with MILVAN/container longitudinal while approaching.

- (9) Rotate tophandler 90 degrees counterclockwise to travel position.
- (10) The boom cannot be raised high or the tophandler will hit the boom.
- (11) The RTCH must be in travel mode before it can be moved.

Note. View Slides # 132 and # 133.

b. Picking up Container at an Angle.

- (1) When approaching a row of MILVAN/containers for pick up, approach at an angle of greater than 45 degrees.
- (2) Extend boom and position the center of tophandler in the center of the MILVAN/container. Position left or right wheel as close as possible to MILVAN/container.
- (3) When extending the boom the maximum lifting capability can be exceeded, If the MILVAN/container is loaded.
- (4) If the lifting capability is exceeded increase the angle.

Note. Conduct a check on learning and summarize the learning activity.

Check on Learning

Determine if the students have learned the material presented by soliciting student questions and explanations. Ask the students the following questions and correct student misunderstandings.

- Q. Why should the multiple function button be used when releasing and raising tophandler from the MILVAN/container?
- A. This will allow a smooth release of the tophandler when the tophandler is raised from the MILVAN/container.

- Q. What is the weight limit on row two containers?
- A. All tiers of row two containers have a weight limit of 27,500.

- Q. When picking up a container longitudinal what is the height limit?
- A. One high only 20-foot or 40-foot the tophandler will hit boom.

- Q. When picking up a container longitudinal the tophandler must be rotated clockwise or counterclockwise?
- A. The tophandler must be rotated 90 degrees clockwise to longitudinal position.

REVIEW/SUMMARIZE: This lesson supports Army operations doctrine and concepts and discusses the safe operation of the Kalmar RT-240 RTCH.

TRANSITION TO THE NEXT LESSON: Read your syllabus for the next lesson, location, and study assignment.

TESTING REQUIREMENTS: Describe how the student must demonstrate accomplishment of the TLO standard. Refer student to the Student Evaluation Plan.

FEEDBACK REQUIREMENT: Rapid, immediate feedback is essential to effective learning. Schedule and provide feedback on the evaluation and any information to help answer students' questions about the test. Provide remedial training as needed

CHAPTER 8

LESSON OUTLINE FOR OPERATIONS UNDER UNUSUAL CONDITIONS

8-1. LESSON TITLE: OPERATIONS UNDER UNUSUAL CONDITIONS

MOTIVATOR: Using personal experience or related story, give a brief explanation of why this lesson is important to the student.

TERMINAL LEARNING OBJECTIVE: Inform students of the terminal learning objective (TLO) requirements. At the completion of this lesson you will:

Action: After this lesson, the student will be knowledgeable of the responsibilities of the Kalmar RT-240 RTCH operation and skills of the controls, and instruments. To lift and transport containers, Under Unusual Conditions, prepare the RT-240 RTCH for transport, and install the Forklift Kit.

Condition: Given TM 10-3930-675-10-1, TM 10-3930-675-10-2, and Kalmar 53,000-pound RT-240 RTCH. You (the student) will operate under unusual conditions, place the cab and boom in transport position for aircraft loading or deployment, and install the Forklift Kit.

Standard: To receive a "GO" for this lesson, the student will be familiar with the starting/operating/stopping procedures, of lifting and transporting containers, with the Kalmar 53,000-pound RT-240 RTCH Under Unusual Conditions, student will be able to accomplish the task of placing the cab and boom in the transport mode, and of installing the Forklift Kit.

SAFETY REQUIREMENTS:

- Instructor will use Appendix C (60 Rules of Safety for Operating Material Handling Equipment (MHE)) to conduct a safety briefing before operations begin each morning and maintain direct supervision throughout the day.
- Safety will be discussed and practiced throughout this lesson.
- Safety clothing (hard hats, gloves, and steel toed boots, hearing protection) will be worn at all times while performing these tasks.
- One Instructor will be with MHE at all times with one student without TA 50. Student will sound warning before movement. Back only with ground guides using 3-point system. Look before backing and keep looking back until stopped. Never back long distances and never use mirrors for backing.

RISK ASSESSMENT LEVEL: Moderate.

ADDITIONAL COMMENTS AND INFORMATION: Recommended instructional time is 12 hours (4.0 Conference and 8.0 Practical Exercise on Operations Under Unusual Conditions).

ENVIRONMENTAL CONSIDERATIONS: It is the responsibility of all Soldiers and DA civilians to protect the environment from damage. AR 200-1 delineates TRADOC responsibilities to integrate environmental requirements across DOTMLPF and ensure all training procedures, training materials, and training doctrine, to include sound environmental practices and considerations. The Army's environmental standard is to be a national leader in environmental and natural resource stewardship for present and future generations. This training support package meets this standard.

EVALUATION: Inform the Soldiers how, when, and where performance of the TLO will be evaluated.

This lesson is examinable under performance test.

INSTRUCTIONAL LEAD IN: Transition students to presentation using personal experience or related story explain why this lesson is important to the students. Instructors should use the following slides from Appendix A:

- Slide #134, Slide #135, Slide #136, and Slide #137 for ELO A (Lift and Transport Containers Under Unusual Conditions).
- Slide #138 through Slide #150 for ELO B (Install the Forklift Kit).
- Slide #151 through Slide #169 for ELO C (Prepare the KALMAR RT-240 for Transport).

ENABLING LEARNING OBJECTIVE A

After this lesson, the student will have the knowledge and responsibilities of the Kalmar RT-240 RTCH operation and skills of the controls and instruments.

8-2. LESSON TITLE: LIFT AND TRANSPORT CONTAINERS UNDER UNUSUAL CONDITIONS

Action: After this lesson, the student will be able to lift and transport containers under unusual conditions.

Condition: Given TM 10-3930-675-10-1, TM 10-3930-675-10-2, and a Kalmar 53,000-pound RT-240 RTCH. 11 You (the student) will demonstrate the operation, and use of the Kalmar RT-240 RTCH Under Unusual Conditions with Boom and Tophandler Joystick Controls.

Standard: To receive a "GO" for this lesson, the student will be able to accomplish the task of lifting and transporting containers, with the Kalmar 53,000-pound RT-240 RTCH Under Unusual Conditions.

1. Learning Step/Activity 1. Link lesson plan to individual tasks taught - Kalmar RT-240 RTCH Operations Under Unusual Conditions.

Note. This vehicle has been designed to operate safely and efficiently within the limits specified in TM 10-3930-675-10-1 and TM 10-3930-675-10-2. Operation beyond these limits is prohibited in accordance with AR 70-1.

Note. View Slide # 134.

a. Slave Starting. When slave starting truck, use NATO slave cable that does NOT have loose or missing insulation.

(1) DO NOT proceed if suitable cable is not available.

(2) DO NOT use civilian-type jumper cables.

(3) The Kalmar RT-240 RTCH is equipped with a 24 volt, negative ground electrical system. The truck has two slave receptacles. One receptacle is located on the left side of the truck within the battery box. The other receptacle is located on the right side of the truck to the rear of the right front tire.

(4) Connect slave cable to booster vehicle slave receptacle,

(5) Connect other end of slave cable to disabled vehicle slave receptacle.

(6) Ensure disabled vehicle's master battery switch is in the ON position.

(7) Start booster vehicle and run at a speed just above idle.

(8) Wait approximately five minutes, before start-disabled vehicle. If vehicle fails to start, notify organizational maintenance.

(9) After starting disabled vehicle, return booster vehicle to idle.

(10) Remove the slave cable from disabled vehicle, then from booster vehicle.

b. Towing.

(1) DO NOT tow at speeds over five mph.

(2) DO NOT attempt to start the Kalmar RT-240 RTCH by towing. Any attempt to start the engine by towing will cause damage to the transmission.

(3) The preferred method for towing a disabled RTCH is with another RTCH, if one is available.

(4) The truck must ONLY be towed a short distance and at slow speeds.

(5) Distance towed and speed may not exceed 15 miles at five mph (25 km at 8 kph). If it is absolutely necessary to move the truck more than 15 miles (24 km), it must be transported.

(6) Because the engine is not running during towing, the following vehicle systems will NOT function properly.

(7) Steering control will be greatly reduced.

(8) Service brakes will not function.

(9) Parking brakes will not release.

(10) Transmission lubrication will be insufficient.

c. Emergency Lowering of the Boom.

(1) Use the following procedures to lower the boom if the engine fails during RTCH operation.

(2) Boom movement during emergency lowering will be slow. This is normal.

Note. View Slide # 135

(3) Lower boom (retracted and unloaded).

(a) Loosen emergency lowering valve jam nuts on both left and right lift cylinder-locking valves.

(b) Turn both left and right emergency lowering valve screws counterclockwise three turns.

(c) Turn left emergency lowering valve screw an additional three counterclockwise turns.

(d) Turn right emergency lowering valve screw an additional three counterclockwise turns.

(e) When boom is full lowered, close both left and right emergency lowering valve screws by turning them clockwise until tight.

(f) Tighten both left and right jam nuts.

Note. View Slide # 136.

(4) Lower boom (extended or loaded with a container).

(a) Open valve located under vehicle, on right frame forward of right-rear tire.

(b) Turn vehicle ignition on.

(c) Press auxiliary pump switch on instrument panel on. It will run for four minutes, and then pause for two minutes, then restart, if necessary.

(d) Use joystick to lower and retract the boom.

Note. Conduct a check on learning and summarize the learning activity.

2. Learning Step/Activity 2. Link lesson plan to individual tasks taught - Operate Kalmar RT-240 RTCH in Weather Conditions.

a. Operate in Extreme Cold.

(1) Extreme cold causes many problems:

(2) Lubricants thicken or congeal.

(3) Batteries may freeze or lose their electrical efficiency.

(4) Fuel may not readily atomize for combustion.

(5) Various materials will become hard, brittle, and easily damaged.

(6) The cooling system requires adequate protection from extreme cold.

(7) Fuels, lubricants, and antifreeze compounds require special storage, handling, and use.

(8) Notify organizational maintenance to prepare vehicle for arctic operation.

(9) Vehicles assigned to arctic regions are equipped with an auxiliary arctic heater to enable easier starting by providing preheating of engine cooling system.

(10) When starting in extreme cold, follow these procedures:

(a) Be careful when you first start your vehicle. Use cold weather starting procedure and allow engine time to reach operating temperature range of 180° F to 200° F (82° C to 93° C). Be alert that tires may be frozen to ground.

(b) Start driving very slowly for about 100 yards. If a problem is noted, notify organizational maintenance as required.

(c) If vehicle will be parked for a short period, park in a sheltered area out of wind. If shelter is not available, park vehicle so right side, where radiator is located, does not face into the wind.

(d) If vehicle will be parked for a long shutdown period, try to park on high ground and use planks or brush to make a raised and relatively dry surface. Keep tires out of snow, water, ice, and mud, if possible.

(e) Clean snow, ice, and mud from vehicle as soon as possible after shutdown.

(f) If vehicle will be parked for a long period of time, have organizational maintenance remove and store batteries. Fill fuel tank to guard against condensation and drain any accumulated water from air reservoirs and fuel filters.

(g) Ensure tires are properly inflated.

b. Operate in Extreme Heat.

(1) During very hot weather, driving procedures may require altering to prevent vehicle overheating. Avoid continuous high engine RPMs, and continuous operation in soft terrain.

(2) Check water temperature display and stop if temperature is unusually high. Allow vehicle to cool down.

(3) Check cooling system, air cleaner, air cleaner restriction indicator, engine oil level, and radiator fins frequently. Perform necessary services and notify organizational maintenance of any unusual readings or problems,

(4) Notify organizational maintenance to shorten differential oil change interval.

(5) Park vehicle under cover, if possible. If shelter is not available, cover vehicle with tarpaulins. If there are not enough tarps to cover entire vehicle, arrange tarps around engine compartment and over radiator to keep sand and dust out. Cover window glass to protect against sand blasting.

(6) Ensure all tires are inflated to proper pressure.

(7) Check frequently for rust. Clean and lubricate vehicle to help prevent deterioration.

c. Operate in Mud or Soft Surfaces.

(1) Before entering mud or other soft surfaces, check conditions and select appropriate transmission gear range. Use four-wheel drive as required. Enter soft area at a medium speed for gear range selected.

(2) Maintain steady pressure on accelerator pedal to keep vehicle rolling until solid ground is reached. Do not accelerate to point where wheels spin, if possible.

(3) If vehicle gets stuck, try to pull out slowly in a low gear. Boards, brush, or similar materials may be placed under tires to provide traction.

(4) Notify organizational maintenance to clean and inspect propeller shafts for proper lubrication.

d. Operate in Sandy or Dusty Conditions.

(1) Maintain steady, even movement with transmission in lower gears. Use four-wheel drive as required. Try to keep vehicle rolling without straining engine and power train. If vehicle gets stuck, notify organizational maintenance.

(2) If vehicle bogs down after tire pressure has been reduced, place boards, brush, canvas, or similar materials under and in front of tires after shoveling a clear path ahead of each tire. This should improve traction.

(3) If these efforts fail and it becomes evident that vehicle will not free itself, have another vehicle tow stuck vehicle.

(4) Service engine air cleaner and cab air filter more frequently.

(5) Make sure each tire has a valve cap.

(6) Check engine and transmission temperature and engine oil pressure frequently.

(7) If vehicle overheats, stop and find out why. Service or notify organizational maintenance, as necessary.

(8) Make sure engine oil filler tube and transmission fluid filler tubes are cleaned before dipsticks are removed to check fluid levels. Clean accumulations of sand and dirt from around fluid filler locations before checking or adding fluids.

(9) Clean spouts of fuel containers and areas around filler caps on fuel tanks before adding fuel. Under extremely sandy or dusty conditions, filter fuel when filling tanks.

(10) Cover window glass to protect against sand blasting.

(11) Notify organizational maintenance to clean, inspect, and lubricate propeller shafts more frequently.

e. Operate in Woods or on Rocky Terrain. Ensure vehicle can clear any obstructions and try to avoid low hanging tree limbs that might cause damage.

f. Operate on Snow and Ice.

- (1) Accelerate slowly to avoid spinning tires.
- (2) Drive at slower speeds.
- (3) Give signals sooner.
- (4) Apply brakes sooner to give early warning of intention to stop. This will also help to avoid skidding.
- (5) Maintain double the normal distance from the vehicle ahead.
- (6) Keep windshields, windows, mirrors, and lights clean and free of snow and ice. Use defroster to help keep glass free of snow and ice.
- (7) If a difficult stretch of road approaches, stop and inspect it carefully before driving on it. Select transmission gear range that best suits road condition. Use four-wheel drive as required.
- (8) If stopping ease up on accelerator, leaving vehicle in gear.
- (9) Apply service brakes lightly and evenly. DO NOT pump service brake pedal.
- (10) Always avoid sudden braking.
- (11) If parking on icy, slushy, wet or muddy surfaces, place boards, brush or other materials that will provide traction underneath tires. This will guard against tires freezing to the ground or becoming pocketed in ice, and will provide some traction when vehicle is started and moving again.

Note. Conduct a check on learning and summarize the learning activity.

3. Learning Step/Activity 3. Link lesson plan to individual tasks taught - Kalmar RT-240 RTCH Operations Under Fording Conditions.

Note. View Slide # 137

a. Fording.

- (1) Maximum fording depth is 60 inches.
- (2) Check water depth in several places, thereby allowing for inconsistency of bottom. Ensure that bottom of stream is hard enough to be forded, without exceeding maximum fording depth. Do not attempt to ford even the narrowest stream that is more than 60 inches in depth.

b. Before Fording.

- (1) Ensure engine is operating properly and all indicators are indicating normal operating pressures and temperatures.

(2) Lubricate unpainted surfaces to guard against rust and deterioration.

c. During Fording.

(1) Place transmission in lower gear ranges and enter water slowly.

(2) Allow cooling fan stop.

(3) Ford at speeds of 3 mph to 4 mph.

d. After Fording.

(1) Allow engine to run for a while to drive out any accumulated water.

(2) Drain and dry any area where water has accumulated.

(3) Check all fluids for signs of contamination and for proper levels.

(4) Lubricate all grease fittings below water line.

(5) If truck has operated in salt water, rinse the entire vehicle with fresh water as soon as possible.

(6) Notify organizational maintenance to remove drain plug from engine flywheel housing and check for signs of water.

Note. Conduct a check on learning and summarize the learning activity.

Checking on Learning

Q After connecting booster vehicle to disabled. Approximately how long should it run before starting disabled vehicle?

A. Approximately five minutes. If vehicle fails to start, notify organizational maintenance

Q At what speed can a disabled vehicle be towed?

A. DO NOT tow at speeds over 5 mph

Q At what distance can a disabled vehicle be towed?

A. Distance towed may not exceed 15 miles. If it is absolutely necessary to move the truck more than 15 miles it must be transported.

Q What is the maximum fording depth of the Kalmar RT-240 RTCH?

A. Maximum fording depth is 60 inches.

ENABLING LEARNING OBJECTIVE B

Note. Inform the students of the enabling learning objective (ELO) requirements.

8-3. LESSON TITLE: INSTALL THE FORKLIFT KIT

Action: After this lesson, the student will have the knowledge and responsibilities to install the Forklift Kit on the Kalmar RT-240 RTCH.

Condition: Given TM 10-3930-675-10-1, TM 10-3930-675-10-2, and a Kalmar 53,000-pound RT-240 RTCH. You (the student) will demonstrate the knowledge to install the forklift kit.

Standard: To receive a “GO” for this lesson, the student will be able to accomplish the task of installing the forklift kit on the Kalmar RT-240 RTCH.

1. Learning Step/Activity 1. Link lesson plan to individual tasks taught - Kalmar RT-240 RTCH Forklift Kit Installations.

Note. View Slide # 138.

a. Installing Forklift Kit.

(1) The forklift kit attaches to the tophandler twistlocks and hydraulic system. The forklift is attached with the kit in a folded configuration.

(2) The procedure requires two personnel: one person in the cab operating the joystick controls; one person installing/ removing retaining pins, connecting the hydraulic quick disconnects hoses, and ground guiding the operator.

Note. View Slide # 139.

(3) Position tophandler directly over and level with forklift kit.

(4) Lower tophandler onto forklift kit and secure with twistlocks.

Note. View Slide # 140.

(5) Release locking rings to disconnect two hydraulic hose quick disconnects, located on top left side of the tophandler. Install protective caps on connectors.

Note. View Slide # 141.

(6) Remove protective caps from forklift kit hydraulic hose connectors. Connect the two forklift kit hydraulic hose quick disconnects to the hydraulic hose quick disconnects that were disconnected from the tophandler.

Note. View Slide # 142.

(7) Remove two locking pins and retaining pins that secure upper fork arms to the top frame.

Note. View Slide # 143.

(8) Stow retaining pins on forklift kit top frame.

Note. View Slide # 144.

(9) Slowly tilt the tophandler/forklift kit to the full rearward position while raising the boom. This will allow the upper fork arms to unfold downward.

Note. View Slide # 145.

Note. The following step requires a structure such as an MILVAN/container or a loading dock to complete the unfolding of the lower forks.

(10) Retract the boom and position the truck in front of an MILVAN/container or loading dock.

Note. View Slide # 146.

(11) Remove two locking pins and retaining pins that secure forks to upper fork arms.

Note. View Slides # 147.

(12) Raise the boom until the forks are even with sides of the container or vertical wall of the loading dock.

(13) Extend the boom until the forks are close to the vertical surface.

Note. View Slide # 148.

(14) Place transmission in neutral (N).

(15) Slowly tilt the tophandler/forklift kit forward, and then raise the boom. This will allow the RTCH to move rearward and the forks to fold out to the horizontal position.

Note. View Slide # 149.

(16) Retract the boom and level the forklift kit using the joystick tilt control.

WARNING
UPPER FORK ARMS WILL HIT THE WHEELS.

Note. View Slide # 150.

(17) Install retaining pins and locking pins to secure forks to upper fork arms.

(18) Retaining pins should be installed from the outside.

b. Forklift Kit Limitation.

(1) The fork tines are adjustable from 24 inches center-to center to 81.5 inches center to center.

(2) Lift capacity is 44,000 pounds.

(3) Height is limited to 8 feet, 6 inches.

Note. Conduct a check on learning and summarize the learning activity.

Check on Learning

Determine if the students have learned the material presented by soliciting student questions and explanations. Ask the students the following questions and correct student misunderstandings.

- Q How is the forklift kit attached to the Kalmar RT-240 RTCH?
A. The forklift kit attaches to the tophandler twistlocks and hydraulic system.
- Q What is the Lift capacity of the Forklift kit?
A. 44,000 pounds.
- Q Where are the locking pins stowed when operating?
A. Stow retaining pins on forklift kit top frame.

REVIEW/SUMMARIZE: This lesson supports Army operations doctrine and concepts and discusses the safe operation of the Kalmar RT-240 RTCH.

TRANSITION TO THE NEXT LESSON: Read your syllabus for the next lesson, location, and study assignment.

TESTING REQUIREMENTS: Describe how the student must demonstrate accomplishment of the TLO standard. Refer student to the Student Evaluation Plan.

FEEDBACK REQUIREMENT: Rapid, immediate feedback is essential to effective learning. Schedule and provide feedback on the evaluation and any information to help answer students' questions. Provide remedial training as needed.

ENABLING LEARNING OBJECTIVE C

Note. Inform the students of the enabling learning objective (ELO) requirements.

8-4. LESSON TITLE: PREPARE THE KALMAR RT-240 ROUGH TERRAIN CONTAINER HANDLER FOR TRANSPORT

Action: After this lesson, the student will have the knowledge and responsibilities to prepare the Kalmar RT-240 Rough Terrain Container Handler (RTCH) for transport.

Condition: Given TM 10-3930-675-10-1, TM 10-3930-675-10-2, and a Kalmar 53,000-pound RT-240 RTCH. You (the student) will demonstrate the knowledge to place the cab and boom in transport position for aircraft loading or deployment.

Standard: To receive a "GO" for this lesson, the student will be able to accomplish the task of placing the cab and boom in the transport mode of the Kalmar 53,000-pound RT-240 RTCH.

1. Learning Step/Activity 1. Link lesson plan to individual tasks taught - Kalmar RT-240 RTCH Preparations for Transport.

Note. In order to prepare the Kalmar RT-240 RTCH for transport, all procedures, except for self deployment, require that the Boom Support be lowered. The Boom Support cannot be lowered unless the Cab has first been placed in Transport Position (to the left and fully lowered).

Note. View Slide # 151.

a. Self-Deployment. The RTCH may be deployed with forklift kit attached only when moving between remote areas, NOT on highways or streets. Forklift kit may also only be deployed with tophandler oriented in normal operational position, NOT longitudinal position. With forklift kit attached, overall lowered height of vehicle is increased by 3 feet (0.9 meters). This makes the lowered height (with clearance under forklift kit) approximately 193 inches (490 centimeters). This height is acceptable for movement between remote areas, but not for highway and/or street movement, due to overhead wires and structures.

- (1) Extend boom.
- (2) Rotate tophandler 90 degrees clockwise to longitudinal position.
- (3) Position boom in horizontal position. Load control display should read 0 degrees and overall lowered height (OALH) should read 160 inches.
- (4) Retract boom until tophandler is in close proximity to front tires.
- (5) Select two-wheel steer mode.
- (6) Turn on lights and flashers, as required.

Note. View Slides # 152 thru # 157.

b. Placing Cab in Transport Position. If RTCH cab is being moved to transport position in order to perform maintenance, it may not be possible to run engine. Auxiliary pump will operate without engine running.

- (1) Run RTCH engine at idle.
- (2) If RTCH must be moved after cab is lowered. It can only be moved in two-wheel drive and first gear. Two-wheel drive can only be selected with cab in operational position.
- (3) Select two-wheel drive before lowering cab.
- (4) Skip the next step if RTCH cab is being moved to transport position in order to perform maintenance or if boom support is not going to be lowered.
- (5) If boom support is to be lowered, remove retaining pin from boom support locking pin extension on each side of boom support.
- (6) Release cab by removing two retaining pins and pins from cab sub-frame.
- (7) Remove two retaining pins and remove handrail.
- (8) Push auxiliary pump switch on instrument panel inside cab to start auxiliary pump.
- (9) Open door of remote hydraulic control compartment.
- (10) Pull cab lift/lower lever to raise cab transport lift until cab track is level with current cab position.
- (11) Pull cab side movement lever until cab has moved all the way to the left and safety locks drop into place on cab track.
- (12) Slowly push cab lift/lower lever and lower cab to transport height.
- (13) Push cab side movement lever to move cab slightly to the right, so that cab securing pins can be installed.
- (14) Pins should be installed from the rear. Install rearmost pin first.
- (15) Install two pins and retaining pins to secure cab in transport position.
- (16) Close and latch door of remote hydraulic control compartment.
- (17) Reinstall handrail, now configured as a ladder, on cab in transport position. Secure with two retaining pins.
- (18) Push auxiliary pump switch on instrument panel inside cab to turn off pump.

Note. Conduct a check on learning and summarize the learning activity.

2. Learning Step/Activity 2. Link lesson plan to individual tasks taught - Preparation for Air Transport.

a. Air Transport.

(1) RTCH is certified for airlift on C-17 and C-5.

(2) The measurement and weight must be reduced to L 561 inches x W 144 inches and with height of less than 138 inches at forward end of Boom. With a Total weight of 116,200 pounds.

(3) No single axle can exceed 36,000 pounds.

(4) The following provision will meet this certification weights:

Total 4 Dolly Wheels	26,200 pounds
Dolly Wheel	6,550 pounds each
Axle # 1	29,000
Axle # 2	34,000
Axle # 3	27,000 Bogie Wheels

(5) Fuel tank must be drained to 1/4 tank or less.

(6) Position RTCH in line with and facing aircraft loading ramp, as close as possible to aircraft.

(7) Ensure RTCH is properly aligned with aircraft.

(8) Once dolly wheels are installed on tophandler.

(9) RTCH is very difficult to steer.

(10) Always use a ground guide and do not exceed 1 mph when driving RTCH up ramps in preparation for air transport. Failure to use a ground guide may result in an accident, causing death or injury to personnel or damage to equipment.

b. Placing Boom Support in Transport Position.

(1) Boom must be raised to 19 degrees and extended to 110 inches as shown on ECS display screen.

(2) Tophandler must be rotated 90 degrees to longitudinal position. Engage oscillation and tilt lock.

(3) To ensure tophandler does not contact underside of boom, exercise tilt function and lock tophandler in tilted position while rotating tophandler. Failure to do so may damage tophandler and/or boom.

(4) Locking Pin Lever, Folding Boom Support Lever, and Bogie Wheel Lever will not operate until cab is folded.

Note. View Slide # 158.

- (5) If not previously removed, remove retaining pin from boom support locking pin extension on each side of boom support.
- (6) Run RTCH engine at idle.
- (7) Open door of remote hydraulic control compartment.
- (8) DO NOT operate locking pins lever and folding boom support lever at the same time. If levers are operated at the same time, boom support locking pin extensions may shear.
- (9) If the hydraulic function for boom support locking pins, boom folding or bogie wheel lowering is not working; it may be necessary to reposition cab closer to the frame.
- (10) Left and right boom support locking pins may not retract at the same time; keep pushing locking pins lever until they both retract. Locking pins may also be difficult to retract.
- (11) Work locking pins lever back and forth several times to get both pins retracted.

Note. View Slides # 159 and # 160.

- (12) Raise boom-folding cylinders to aid in releasing boom support locking pins.
- (13) Push locking pins lever to retract boom support locking pins.
- (14) Ensure locking pins are fully retracted to avoid damaging them.
- (15) Visually inspect both sides to ensure left and right boom support locking pins have fully retracted.
- (16) Push folding boom support lever to fold boom support.
- (17) For highway or rail transport, lower boom support until it will not fold any more.
- (18) For air transport, lower boom support to 30-degree mark on frame.
- (19) Pull locking pins lever to extend boom support locking pins. Install retaining pins to secure in locked position.
- (20) For air loading leave boom on 30-degree mark on frame.
- (21) Lower tophandler until approximately 18 inches off the ground.
- (22) Install front and rear dolly wheels on tophandler.
- (23) Open dolly wheels storage compartment. Remove ramp from stowage and position against storage compartment.
- (24) Remove dolly wheels from storage compartment, using ramp.

Note. View Slide # 161.

(25) Ensure that tabs on ramp are engaged into ramp seat holes in dolly wheels storage compartment. Failure to secure ramp properly may cause ramp to fall under weight of dolly wheel, causing injury to personnel.

Note. View Slide # 162.

(26) Install each dolly wheel to tophandler.

(27) Place dolly wheel so that tire will be under the twistlocks when tophandler is lifted.

(28) Install upper pin from outside of tophandler. Lock pin in position with retaining pin.

(29) Remove lower pin from dolly wheel and set aside.

(30) When installed, front and rear dolly wheels are turned toward each other.

Note. View Slides # 163, # 164, and # 165.

(31) Stow ramp in dolly wheels storage compartment. Secure ramp with straps.

(32) Raise tophandler so that dolly wheels are off the ground approximately 2 feet.

(33) Install lower pin in lower hole of each dolly wheel. Lock pin in position with retaining pin.

(34) Lower tophandler until all four-dolly wheels are resting on ground.

(35) After installing dolly wheels to tophandler: the boom must be aloud to float on the dolly wheels when loading on aircraft.

(36) At side of locking valve at base of each lift cylinder, loosen float valve jam nut and turn float valve screw five turns counterclockwise. Retighten jam nut to prevent loss.

(37) Turn valve screw slowly to allow pressure to bleed off slowly if boom is not on stops boom may drop.

(38) At front of vehicle, open both shutoff valves SLOWLY AND AT THE SAME TIME.

(39) Tophandler should now be resting on dolly wheels, in floating position.

Note. Show Power Point Slide # 26 thru # 28.

Note. View Slides # 166, # 167, and # 168.

c. Bogie Wheels.

(1) Before loading on Aircraft bogie wheels must be lowered down to relieve some the weight from rear axle.

(2) Slowly pull bogie wheels lever to raise bogie wheels.

(3) Raise bogie wheels only enough to allow bogie wheels retaining collar to be unlocked.

(4) Turn bogie wheels retaining collar 1/4 turn clockwise to unlock bogie wheels. If retaining collar is still tight, use handle stowed forward of bogie wheels to rotate shaft.

(5) Push bogie wheels lever to lower bogie wheels; ensure wheels are lowered sufficiently to apply ground pressure.

(6) Push bogie wheels lever to lower bogie wheels; Ensure wheels are lowered sufficiently to apply ground pressure.

(7) Open shutoff valve number 5 inside remote hydraulic control compartment by turning the handle 90 degrees counterclockwise.

(8) Bogie wheels will lower further and apply correct amount of ground pressure.

Note. View Slide # 169.

d. Loading RTCH on Aircraft.

(1) Steering in two-wheel position.

(2) Cab in transport position.

(3) Boom in transport position (30 degree mark).

(4) Dolly wheels installed on tophandler.

(5) Boom in float position.

(6) Bogie wheels float position.

(7) The RTCH is now ready to load on aircraft.

(8) DO NOT exceed 1 mph speed.

(9) Using first gear and two-wheel steering mode slowly drive RTCH forward up ramps and position inside aircraft.

(10) Only slight steering corrections (NO MORE THAN 1/4 TURN OF STEERING WHEEL) are allowed during loading.

(11) Over steering will damage dolly and bogie wheels.

e. After Loading is Complete.

(1) Lower boom support to the maximum onto the frame.

(2) Rotate bogie wheels retaining collar $\frac{1}{4}$ turn clockwise to lock bogie wheels in position. It may be necessary to screw shaft down to take up slack in bogie wheels lock.

(3) Close shutoff valve number 5 by turning handle 90 degrees clockwise.

(4) Shut down RTCH engine.

(5) Tie boom to RTCH frame.

(6) Secure RTCH to tie down locations inside aircraft in accordance with tie down instructions on RTCH data plate and on aircraft.

Note. Conduct a check on learning and summarize the learning activity.

Check on Learning

Determine if the students have learned the material presented by soliciting student questions and explanations. Ask the students the following questions and correct student misunderstandings.

Q What steering mode must the Kalmar RT-240 RTCH be in to load on C-5 Aircraft?

A. Two-wheel steering mode.

Q Boom support should be at what location for loading on C-17?

A. For air transport, boom support must be at 30-degree mark on frame.

Q Float valves on lift cylinders should be opened before or after dolly wheels are installed?

A. Float valves should be opened after dolly wheels are installed five turns counterclockwise.

Q Bogie wheels should be in float position before or after loading on aircraft?

A. Bogie wheels must be allowed to float when going up or down ramps.

CHAPTER 9

END-OF-COURSE TEST**9-1. LESSON TITLE: END-OF-COURSE TESTING**

Note. All previously task lessons taught.

A. COURSE TRAINING OBJECTIVE.

Task: Complete the Practice Written Test and Performance Test.

Condition: Given an Examination Test booklet, pencil, DD Form 1970 (Motor Equipment Utilization Record) or ULLS-generated DA Form 5987-E (Motor Equipment Dispatch), DA Form 2404 (Equipment Inspection and Maintenance Worksheet) or ULLS-generated DA Form 5988-E (Equipment Inspection Maintenance Worksheet), TM 10-3930-675-10-1, TM 10-3930-675-10-2, equipment record folder, rags, lubrication, coolant, a Kalmar 53,000-pound RT-240 RTCH with basic issue items (BII), and a suitable off road training area.

Standard: Complete the Practice Written Test and Performance Test. Even though not graded, the purpose of the Practice Written Test is to determine if Soldiers selected for training and licensing have adequate knowledge in the proper operation and familiarization of the KALMAR RTCH RT-240. Students must obtain an overall score of 75 percent or higher on the Performance Test.

B. INTERMEDIATE TRAINING OBJECTIVES.**INTERMEDIATE TRAINING OBJECTIVE 1**

Action: Complete the Practice Written Test.

Condition: Given a test booklet with 25 questions and pencil.

Standard: Complete the Practice Written Test and check your answers with the Answer Key provided.

INTERMEDIATE TRAINING OBJECTIVE 2

Action: Complete the Performance Test while operating the Kalmar 53,000-pound RTCH RT-240.

Condition: Given DD Form 1970 (Motor Equipment Utilization Record) or ULLS-generated DA Form 5987-E (Motor Equipment Dispatch), DA Form 2404 (Equipment Inspection and Maintenance Worksheet) or ULLS-generated DA Form 5988-E (Equipment Inspection Maintenance Worksheet), TM 10-3930-675-10-1, TM 10-3930-675-10-2, equipment record folder, rags, lubrication, coolant, a suitable off road training area, a RTCH with BII, and a requirement to operate the RTCH off road (to include ditches, marshes, gullies, ravines, steep grades, woods, mud, rocky terrain, and shallow streams (60 inches or less) during daylight hours.

Note. The commander may modify or eliminate some of the above requirements based on availability of the required terrain.

Standard: Operate the RTCH safely at reduced speeds, taking precautions to prevent damage to the equipment while driving over rough terrain and obtain an overall score of 75 percent or higher on the performance test checklist items.

C. ADMINISTRATIVE INSTRUCTIONS.

1. Training time: As scheduled.
2. Training Location: Motor pool and off road training areas as scheduled.
3. Training Type: Hands-On Performance evaluation.
4. Students: Scheduled personnel.
5. Primary and Assistant instructors as required.
6. Training Aids and Equipment: Hearing protection and rags.
7. DD Form 1970 (Motor Equipment Utilization Record) or ULLS-generated DA Form 5987-E (Motor Equipment Dispatch), DA Form 2404 (Equipment Inspection and Maintenance Worksheet) or ULLS-generated DA Form 5988-E (Equipment Inspection Maintenance Worksheet), TM 10-3930-675-10-1, TM 10-3930-675-10-2, equipment record folder, rags, lubrication, coolant, a RTCH with BII , and a suitable off road training area.
8. References: AR 385-10, AR 600-55, AR 611-5, DA Pamphlet 750-8, FM 21-305, TM 10-3930-675-10-1, and TM 10-3930-675-10-2.

D. SEQUENCE OF ACTIVITY.

1. Introduction.
 - a. Interest device.
 - b. Tie-in.
 - c. Lesson Objective (Paragraph A).
 - d. Course Intermediate Training Objective 1 and Objective 2.
 - e. Discuss Safety Requirements before operation.
 - f. Perform PMCS before operation.

2. Procedures.
 - a. Practice Written and Performance testing.
 - b. Evaluation.
 - c. Summary.

Note. The student must successfully complete the practice written test before completing the performance test.

- (1) Intermediate Training Objective # 1 (Practice Written Test).
- (2) Intermediate Training Objective # 2 (Off Road Hands-On Performance Test).

3. Evaluate.
 - a. The student taking the practice written test must check their results with the answer key provided this training circular and coordinate with the examiner before operation with the RTCH RT-240.
 - b. Examiners will evaluate the performance test using the hands-on evaluation checklists provided in paragraph 9-9.
4. Summary.
 - a. Recap main points.
 - b. Allow for questions.
 - c. Clarify questions.
 - d. Give closing statement.
5. Retraining: Retrain and retest NO-GOs.
6. After-Action Review (AAR). The examiner will review the results of the performance test evaluation checklist with the student to bring to the student attention any weaknesses that require further practice or training. If the operator failed, explain what caused the failure. Advise the student that a standard Army OF Form 346 (US Government Motor Vehicle Operator's Identification Card) cannot be issued and the student will have to retake the entire performance test at a later date.

E. SAFETY RESTRICTIONS.

- Ensure that all chock blocks are in place when vehicles are parked or maintenance is to be performed.
- Ensure that the transmission is in “N”, the parking brake is set, and the engine is shut off before leaving the vehicle, when the vehicle is parked, or maintenance is being performed.
- Ensure all personnel remove all wristwatches, rings, bracelets, ID tags, neck chains, and any other jewelry before working on or around the vehicle.
- Ensure all personnel pay particular attention to the cautions and warnings listed in the operator’s manual.
- Ensure the driver and ground guides know and understand the hand and arm signals, especially the sign to stop, as outlined in FM 21-305.
- Ensure ground guides are used when backing.
- Ensure all backing is conducted at a speed of 5 mph or less.
- Hearing protection is required for all personnel working in the surrounding area of the RT-240 RTCH while the engine is running.
- Inspect the seat belts for damage and ensure that the operator wear the seat belt while operating the RTCH.
- Ensure personnel maintain at least three points of contact when mounting or dismounting the vehicle (to include performing PMCS).
- Ensure all personnel are clear of vehicle before engine start is attempted. Operator must visually check to see that all areas of the RTCH are clear of personnel before attempting to start the engine. Failure to do so could result in serious injury or death to personnel.
- The exhaust pipe and muffler can become very hot during vehicle operation. Be careful not to touch these parts with your bare hands or allow the body to come in contact with the exhaust pipe or muffler. Exhaust system parts can become hot enough to cause serious burns.
- Re-emphasize the removal of all jewelry such as rings, ID tags, or bracelets before working around batteries. Be careful not to short out battery terminals. If jewelry or tools contact the battery terminal, a direct short may occur resulting in instant heating, damage to equipment, or injury to personnel. Do not smoke or use open flame near batteries. Batteries may explode from a spark. Battery acid is harmful to skin and eyes.
- Fuel is very flammable and can explode easily. To avoid serious injury or death, keep fuel away from open fire and keep a fire extinguisher within easy reach when working with fuel. Do not work on the fuel system when the engine is hot. Fuel can be ignited by the hot engine. When working with fuel, post signs that read: “NO SMOKING WITHIN 50 FEET OF VEHICLE”.
- Alcohol used in alcohol evaporator is flammable, poisonous, and explosive. Do not smoke when adding fluid and do not drink fluid. Failure to do this will result in injury or death.

- Apply brakes gradually when slowing or stopping and pump brakes gradually when slowing or stopping the vehicle on ice, snow, or wet pavement. A panic stop will cause the vehicle's wheels to lock, the engine to stall, and power steering will be lost. Failure to apply brakes gradually can result in injury or death.
- Never use the parking brake for normal braking. The wheels will lock up causing a severe skid. A skidding vehicle can result in serious injury or death.
- Excessive use of the service brake to control downhill speed will result in the loss of braking power because of heat buildup.

F. ENVIRONMENTAL CONSIDERATIONS.

- Ensure that all hazardous materials and wastes are stored and labeled properly.
- Ensure that the spill kits are within reach when changing or adding vehicle fluids or in the case of vehicle failures. Spill kits should enable the Soldiers to contain a spill on land or in water.
- Ensure that the drip pans remain under parked vehicles.
- Ensure that the containers are the proper size and type for draining vehicle fluids.

G. ADDITIONAL COMMENTS AND INFORMATION. Recommended testing time for the practice written test and the performance test is 4.0 hours.

9-2. GENERAL INSTRUCTIONS BEFORE TESTING.

1. GENERAL.

a. The purpose of the practice written test is to determine if personnel selected for training and licensing have adequate knowledge in the proper operation and familiarization of the KALMAR RTCH RT 240. The practice written test for the RTCH RT 240 forklift consists of 25 questions.

b. The examiner will be a thoroughly qualified operator of the RTCH. The examiner will also be familiar with the testing procedures as set forth in AR 600-55, AR 611-5, TB 600-2, and this training circular. Before administering the performance test to any examinees, the examiner must practice administering the test to a regular licensed driver qualified on the RTCH RT 240. This practice administration will help the examiner become acquainted with the test route and testing procedures.

c. Select an area to conduct PMCS.

(1) The site should be a flat parking area suitable for heavy equipment.

(2) There should be at least 8 feet of open space around the vehicle. This will give the driver room to conduct the inspection and the examiner room to observe the driver's inspection performance.

(3) The site should be quiet enough that the examiner can hear the driver explain what he/she is doing during the inspection.

(4) Avoid using a parking space on a street or any place where traffic is passing close by.

9-3. DIRECTIONS FOR THE INSTRUCTOR.

1. BEFORE THE PERFORMANCE TEST BEGINS.

- a. Personnel Requirements. The test requires one instructor per two students.
- b. Equipment Needed. Special equipment required for specific tests is noted in the instructor materials for that specific test.
- c. Test Set Up. The performance test is to be administered in a drivers training area environment. The proctor is to explain the following information to students.
 - (1) Proctor's name, course, class number, and examination number.
 - (2) Number of pages in the examination book.
 - (3) Total possible raw points.
 - (4) Total examination time, with start and stop.
 - (5) Any additional information required. (Publications to be used, deleted questions, corrected wording, or special requirements.)

2. DURING THE TEST PERIOD.

a. Prepare Students for the Next Test. Assign each student a time to take the test. Explain that the examination will be given in a drivers training area. Inform students that they must report to the training area with their student test booklets.

b. Management Functions.

- (1) Advise students that questions relating to the interpretation of a question will not be permitted during the conduct of the examination.
- (2) Inform the student how many minutes will be given to complete the examination. Time remaining will be given prior to the conclusion of the examination.
- (3) Students who complete the examination prior to the elapsed time will turn in their test booklets to the proctor and leave the immediate training area until all students have finished or the examination time has expired.
- (4) If a student has to leave the immediate training area for any reason, ensure that student will not have access to information pertaining to the performance test.
- (5) Ask the students if they have any questions on administration.

(6) Pass out the performance examination materials.

(7) Read the instructions to the students.

(8) During the test, answer only those questions which deal with administrative procedures and safety.

(9) Circulate throughout the training area to maintain control.

(10) At the end of the allotted time, stop the test. Any students still taking the test will turn in their booklets at this time. Ensure all materials and equipment is collected.

3. AFTER THE TEST PERIOD.

a. Brief students on the outcome of the performance test. Counsel as necessary.

b. Calculate test scores and enter in students permanent records.

c. Collect and return all equipment used during the test. Ensure all test material is accounted for and that all scrap paper is correctly disposed.

9-4. DIRECTIONS TO STUDENTS.

- The test administrator will record performance scores in your test booklet.
- You will be given 50 minutes each to complete the Performance test. Time remaining will be given at intervals prior to the conclusion of the test.
- You are authorized administrative assistance during the test.
- If you require the instructor during the test, raise your hand. Do not leave your test station or area.
- You are warned that disciplinary action will be taken against any student given or receiving unauthorized information.
- Check your test booklets to ensure that all pages and questions are legible. Once this is done, place your name, SSN, rank, and course number in the upper right hand corner of the test booklet and all related materials. (DO THIS NOW).
- When you have completed the test, ensure your name and all other identification is placed on all test-related material. Hand your test booklet and all worksheets to the instructor.
- After submitting your test materials, leave the examination area and do not return until all students have completed the test or the examination time has expired.

If you have any questions, ask them now.

9-5. DIRECTIONS FOR SCORING AND GRADING.

1. SCORING.

a. Recommended passing grade for the practice written test is 75 per cent or higher. The final approval before operating the RTCH RT 240 will depend on the discretion of Instructor/Examiner.

b. Total scoring is based on 100 percent, with a minimum of 75 percent required to pass the performance test.

c. Each task is to be assessed on a GO/NO-GO basis.

d. The total number of raw points is to be calculated to represent the percentile value.

2. GRADING.

a. Calculate test scores and enter in students permanent records.

b. Inform the senior instructor of all failures for counseling requirement.

9-6. SCORER INSTRUCTIONS FOR THE HANDS-ON PERFORMANCE TEST. You must consider every element of each major section of the test when you give the student an overall rating for the section. You must grade each task on a GO/NO GO basis, following the performance standards established in each section. Evaluation sheets are provided. In grading each Soldier, decide whether or not performance deficiency is due to factors such as test anxiety, lack of experience, or poor attitude.

a. If the deficiency is due to lack of experience, you may give the Soldier a GO, knowing the student will get the necessary experience in a unit.

b. Never assign a GO due to lack of skills and knowledge.

c. Ask if there are any questions. If there are none, begin the test, following the procedures outlined in each section.

d. Record grades on Soldier's score sheet.

**INTERMEDIATE TRAINING OBJECTIVE 1
PRACTICE WRITTEN TEST**

9-7. MULTIPLE CHOICE PRACTICE WRITTEN TEST. The students are required to complete the 25 multiple choice questions test below in order to meet the training requirements for the Intermediate Training Objective 1.

NAME _____ RANK _____ DATE _____

Instructions for Test

- A. This test consists of 25 multiple choice questions.
- B. Read all questions and answers carefully; then circle the correct answer a, b, c, or d to the left.
- C. Any unanswered questions will be scored as incorrect responses.

1. What is the Technical Manual (TM) number that covers the operation of the RTCH RT-240?

- a. TM 5-3810-306-10
- b. TM 10-3930-643-10
- c. TM 10-3930-673-10
- d. TM 10-3930-675-10-1 & 2

2. How high can International Standard Organization (ISO) containers be stacked with the RTCH RT-240?

- a. Two
- b. Three
- c. Four
- d. Five

3. The RTCH RT-240 will ford up to how many inches of water?

- a. 40
- b. 50
- c. 60
- d. 70

4. When operating the Joy sticks on RTCH RT-240 what is the correct movement required to raise the boom and Tophandler?

- a. Move joystick forward to raise the boom
- b. Move joystick backward to raise the boom
- c. Move joystick left & right to raise the boom
- d. Move joystick right & forward to raise the boom

5. What is the minimum retraction and maximum extension allowed for the Tophandler spreader bar on the RTCH RT 240 in feet?
 - a. 20 and 35
 - b. 20 and 40
 - c. 35 and 40
 - d. 40 and 45

6. What is the fuel tank capacity, in gallons, of the RTCH RT-240?
 - a. 103
 - b. 113
 - c. 130
 - d. 133

7. How many forward and reverse gears are on RTCH RT-240?
 - a. 3 forward and 3 reverse
 - b. 3 forward and 4 reverse
 - c. 4 forwards and 3 reverse
 - d. 4 forward and 4 reverse

8. How many 12 volt batteries are on the RTCH RT-240?
 - a. One
 - b. Two
 - c. Three
 - d. Four

9. What is the RTCH RT 240 coolant system capacity, in gallons?
 - a. 23.7
 - b. 24.7
 - c. 28.7
 - d. 35.7

10. What is the RTCH RT 240 Maximum Forward Reach (Boom Level) in feet?
 - a. 20.6
 - b. 24.6
 - c. 26.0
 - d. 26.4

11. What is one of the goals established for Hazard Communication Standard (HAZCOM) issued by OSHA?
 - a. Review the incidents of injury and illness caused by hazardous chemicals in the work place.
 - b. Report the incidents of injury and illness caused by hazardous chemicals in the work place.
 - c. Reduce the incidents of injury and illness caused by hazardous chemicals in the work place.
 - d. Eliminate the incidences of injury and illness caused by hazardous chemicals in the work place.

-
12. What is the maximum lifting capacity, in pounds, of the RTCH RT-240?
- a. 35,000
 - b. 43,000
 - c. 50,000
 - d. 53,000
13. What is the maximum speed in miles per hour (MPH) can the RTCH RT-240 travel on level ground unload?
- a. 15
 - b. 23
 - c. 35
 - d. 42
14. The RTCH RT 240 has how many steering modes?
- a. 1
 - b. 2
 - c. 3
 - d. 4
15. What color twistlock indicator light indicates that the twistlocks are unlocked?
- a. Red
 - b. Yellow
 - c. Green
 - d. Blue
16. When following another RTCH RT 240 what is recommended distance apart should be maintained between the two vehicles?
- a. Two vehicles length
 - b. Three vehicles length
 - c. Four vehicles length
 - d. Five vehicles length
17. What is the maximum tow speed, in miles per hour (MPH) for the RTCH RT-240?
- a. 3
 - b. 4
 - c. 5
 - d. 6
18. How many NATO slave receptacles are on the RTCH RT-240?
- a. 0
 - b. 1
 - c. 2
 - d. 4

19. What is the correct hand signal, to lock the twist locks or hook up complete?
- a. Both fist facing each other.
 - b. Both hands extended pointing up, palms, facing backward.
 - c. Right hand extended pointing in, palm facing down.
 - d. None of the above.
20. What type of hazard does the illustration with arrows bouncing off the face shield represent?
- a. Cover your face
 - b. Wear your glasses
 - c. Close your eyes
 - d. Flying particles
21. How far down should you press the accelerator when starting the RTCH RT-240?
- a. Half-way
 - b. It is not necessary to press the accelerator
 - c. All the way down
 - d. Three-quarters of the way
22. What is the hand signal to tilt load out or forks up?
- a. There is no signal for this action.
 - b. Left hand displaying the U-sign, and pointed up. Right hand pointed up with palm facing forward.
 - c. Left hand displaying the V-sign, and pointed up. Right hand pointed up with palm facing forward.
 - d. Left hand displaying the V-sign, and pointed up. Right hand displaying the V- sign and pointed down.
23. What distance, in yards, should the ground guide keep between themselves and the vehicle front and rear corners?
- a. 5
 - b. 10
 - c. 15
 - d. 20
24. What color is carbon monoxide?
- a. White
 - b. Light blue
 - c. Gray
 - d. Colorless
25. What is the maximum weight limit, in pounds, when stacking and unstacking the standard 8 feet high MILVAN/ISO containers located in the second row?
- a. 25,500
 - b. 25,750
 - c. 27,500
 - d. 25,550

**INTERMEDIATE TRAINING OBJECTIVE 1
PRACTICE WRITTEN TEST ANSWER KEY**

NAME _____ RANK _____ DATE _____

- | | | | |
|-----|---|-----|----|
| 1. | d | 14. | d |
| 2. | b | 15. | a |
| 3. | c | 16. | a |
| 4. | b | 17. | c |
| 5. | b | 18. | c |
| 6. | a | 19. | a. |
| 7. | c | 20. | d |
| 8. | d | 21. | b |
| 9. | a | 22. | c |
| 10. | a | 23. | b |
| 11. | c | 24. | d |
| 12. | d | 25. | c |
| 13. | b | | |

**INTERMEDIATE TRAINING OBJECTIVE 2
PERFORMANCE TEST – OFF ROAD DRIVING**

9-8. TRAINING EVENT TIMES. The following table reflects established times set for each operator training event required to complete the performance test.

TASK	TIME
Engine Starting	5 minutes
Operate Transmission	3 minutes
Container Lifting	5 minutes
Joystick Operations	3 minutes
Rotation Control Rocker Switch	3 minutes
Container Oscillation Angles.	5 minutes
Tophandler Shifting Positions	5 minutes
Tophandler Lift Positions	5 minutes
Container Tilt Angles	3 minutes
Traveling with Load	5 minutes
Multiple Function Trigger	3 minutes
Shutdown Procedures	5 minutes
Total Time:	50 minutes

Note. All evaluations for performance components are done with a 2-to-1 student/instructor ratio.

9-9. PERFORMANCE TEST CHECKLISTS. The following six sample checklists can be used to conduct the performance test while operating the Kalmar RT-240 RTCH. Instructors can use these checklists or develop their own.

KALMAR ROUGH TERRAIN CONTAINER HANDLER PERFORMANCE TEST

Student Name _____ Class _____ Date _____

HANDS-ON EVALUATION		Date	
Task Title: ROUGH TERRAIN CONTAINER HANDLER			
Item	A. START ENGINE	Raw Points	Earned Points
Note. Have students to start engine under normal conditions with the proper procedures and make all checks.			
1.	Battery Switch. Place master battery switch to ON.	2	
2.	Fasten seat belt.	2	
3.	Ensure that the parking brake is applied.	2	
4.	Place transmission shift control lever to Neutral (N).	2	
5.	Ensure that all accessory switches and controls are in the OFF position.	2	
6.	Turn ignition switch to ON position. System warning lights will illuminate briefly, and then go out.	2	
7.	Turn ignition switch to START and allow the engine to start and run at idle speed.	2	
8.	Increase the engine speed (RPM) slowly to provide adequate lubrication to the bearing and allow the oil pressure to stabilize.	2	
9.	Run engine at idle speed for 3 to 5 minutes before operating with a load.	2	
10.	Turn on service light.	2	
SECTION A, SUBTOTAL:		20	
Evaluator's Name		Unit	
Student's Name		Status: GO ___ NO GO ___	

KALMAR ROUGH TERRAIN CONTAINER HANDLER PERFORMANCE TEST

Student Name _____ Class _____ Date _____

HANDS-ON EVALUATION		Date	
Task Title: ROUGH TERRAIN CONTAINER HANDLER			
Item	B. OPERATE TRANSMISSION	Raw Points	Earned Points
Note. Have students to operate transmission with the proper procedures and make all checks.		2	
1.	Depress and hold brake pedal.	2	
2.	Release parking brake.	2	
3.	Select direction and gear range with transmission control lever.	2	
4.	ALWAYS bring the forklift truck to a complete STOP before changing from forward to reverse to prevent possible damage to the transmission.	2	
5.	Release brake pedal and begin to move truck (RTCH).	2	
SECTION B, SUBTOTAL:		10	
Evaluator's Name		Unit	
Student's Name		Status: GO ___ NO GO ___	

KALMAR ROUGH TERRAIN CONTAINER HANDLER PERFORMANCE TEST

Student Name _____ Class _____ Date _____

HANDS-ON EVALUATION		Date	
Task Title: ROUGH TERRAIN CONTAINER HANDLER			
Item	C. CONTAINER OPERATIONS	Raw Points	Earned Points
Note. Have students pick up and move container conditions using Joystick and proper switch control to make the lift and movement.		2	
CONTAINER LIFTING			
1.	Position the RTCH as close to the container as possible (12 inches to 18 inches).	2	
2.	Position the RTCH near the center and at 90 degree angle.	2	
3.	Apply the parking brake.	2	
4.	Place Transmission control lever in Neutral (N).	2	
JOYSTICK OPERATION			
5.	Move control handle forward to lower the boom.	2	
6.	Move control handle back to raise the boom.	2	
7.	Move control handle right to extend the boom.	2	
8.	Move control handle left to retract the boom.	2	
SECTION C, SUBTOTAL:		16	
Evaluator's Name		Unit	
Student's Name		Status: GO ___ NO GO ___	

KALMAR ROUGH TERRAIN CONTAINER HANDLER PERFORMANCE TEST

Student Name _____ Class _____ Date _____

HANDS-ON EVALUATION		Date	
Task Title: ROUGH TERRAIN CONTAINER HANDLER			
Item	CONTAINER OPERATIONS (continued)	Raw Points	Earned Points
	ROTATION CONTROL ROCKER SWITCH.		
9.	Press left side of rocker switch to rotate load clockwise.	2	
10.	Press right side of rocker switch to rotate load counterclockwise.	2	
	CONTAINER OSCILLATION ANGLES		
11.	Press multiple function trigger button and right side rotation control rocker switch to raise left side of load.	2	
12.	Press multiple function trigger button and right side rotation control rocker switch to raise right side of load.	2	
	TOPHANDLER SHIFTING POSITIONS		
13.	Press right button to shift load to the right.	2	
14.	Press left button to shift load to the left.	2	
	TOPHANDLER LIFT POSITIONS		
15.	Press right button and multiple functions trigger button to widen tophandler from 20 to 30 ft or to open forklift tines, if forklift kit is installed.	2	
	SECTION C, SUBTOTAL:	14	
Evaluator's Name		Unit	
Student's Name		Status: GO ___ NO GO ___	

KALMAR ROUGH TERRAIN CONTAINER HANDLER PERFORMANCE TEST

Student Name _____ Class _____ Date _____

HANDS-ON EVALUATION		Date	
Task Title: ROUGH TERRAIN CONTAINER HANDLER			
Item	C. CONTAINER OPERATION (continued)	Raw Points	Earned Points
	CONTAINER ANGLES		
16.	Press bottom of rocker switch to tilt bottom of load out.	2	
17.	Press top of rocker switch to tilt bottom of load in.	2	
	TRAVELING WITH LOAD		
18.	Engage oscillation and tilt locks before driving with a load.	5	
19.	Center and level.	5	
20.	Position the bottom of the load above your field of view.	5	
21.	Boom fully retracted.	5	
	MULTIPLE FUNCTION TRIGGER		
22.	Use to lower tophandler over load.	2	
23.	Use to raise tophandler from load.	2	
	SECTION C, SUBTOTAL:	28	
Evaluator's Name		Unit	
Student's Name		Status: GO ___ NO GO ___	

KALMAR ROUGH TERRAIN CONTAINER HANDLER PERFORMANCE TEST

Student Name _____ Class _____ Date _____

HANDS-ON EVALUATION		Date	
Task Title: ROUGH TERRAIN CONTAINER HANDLER			
Item	D. Shutdown PROCEDURES	Raw Points	Earned Points
Note. Have students shutdown engine under normal conditions with the proper procedures.			
1.	Apply the parking brake.	2	
2.	Place transmission control lever in Neutral (N).	2	
3.	Retract and fully lower boom.	2	
4.	Allow the engine to run for 1/2 to 1 minute at idle.	2	
5.	Stop the engine by turning ignition switch to 0 position.	2	
6.	Battery switch, place master battery switch to OFF position.	2	
SECTION D, SUBTOTAL:		12	
SECTION A, GRAND TOTAL SCORE		20	
SECTION B, GRANDTOTAL SCORE		10	
SECTION C, GRAND TOTAL SCORE		58	
SECTION D, GRAND TOTAL SCORE		12	
FINAL GRADE (PERFORMANCE TEST)			
Evaluator's Name		Unit	
Student's Name		Status: GO ___ NO GO ___	

Sample

Appendix A

SLIDES

Vehicle Backing

FORWARD MOVEMENT ONLY
WHEN ONE GUIDE IS
AVAILABLE.

NEVER BACK MILITARY
EQUIPMENT WITH ONE
GUIDE.

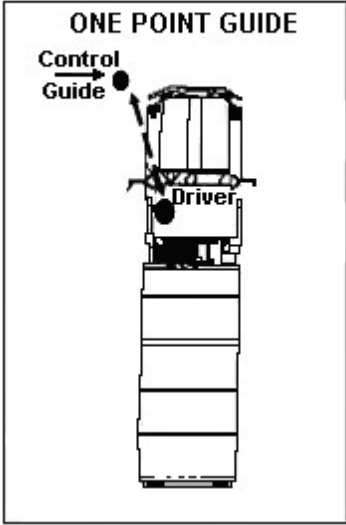

The diagram shows a top-down view of a vehicle with a driver's seat labeled 'Driver'. A single ground guide, labeled 'Control Guide', is positioned to the left of the vehicle. A dashed line indicates the line of sight from the driver to the control guide.

Slide # 1

Vehicle Backing

OPERATION AND
NON CONGESTED
AREA, MINIMUM OF
TWO GROUND
GUIDES WHEN
BACKING A
VEHICLE.

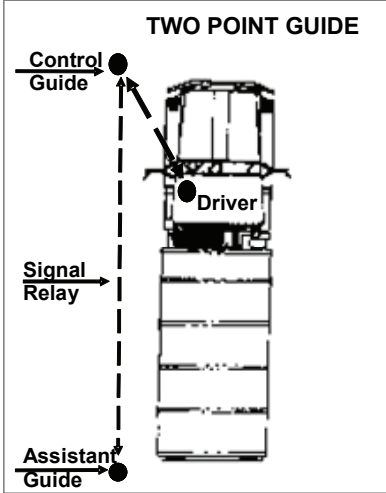

The diagram shows a top-down view of a vehicle with a driver's seat labeled 'Driver'. Two ground guides are positioned: 'Control Guide' to the left and 'Assistant Guide' to the right. A dashed line connects the driver to the control guide. A 'Signal Relay' is located between the two guides, with a dashed line extending from it to the assistant guide.

Slide # 2

Vehicle Backing

IN A CONGESTED AREA, WHEN BACKING A VEHICLE, THERE SHOULD BE THREE GROUND GUIDES.

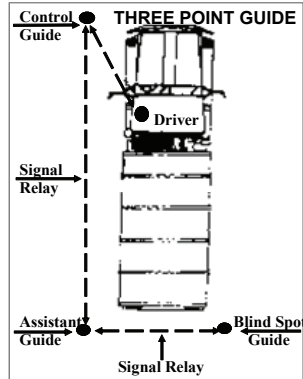

BECAUSE OF THE VISIBILITY RESTRICTIONS THIS IS THE ONLY SAFE METHOD THAT CAN BE USED WITH MHE, 40-TON CRANE, RTCH'S AND FORKLIFTS.

This Method Should Be Used During All Loading Exercises

Slide # 3

Ready



Both Palms Open Hands on Head

Slide # 4

Move Load Very Slowly



Palms Facing Up, Rub Palms Together

Slide # 5

Stop All Movement



**Both Fist Closed, Facing Forward,
Raised Above the Shoulder**

Slide # 6

Dog Down



**Open Palm Facing Forward
and Together at Thumbs**

Slide # 7

Boom Up



**Fist Closed, Thumb Extended and
Pointing Up**

Slide # 8

Boom Down



**Fist Closed, Thumb Extended
and Pointing Down**

Slide # 9

Boom Out



**Fist Closed, Thumb Extended
and Pointing Outward**

Slide # 10

Boom In



**Fist Closed, Thumb Extended
and Pointing Inward**

Slide # 11

Slew Left



**Right Hand Open Palm Facing Forward
and Pointing in Direction of
Left Movement**

Slide # 12

Slew Right



**Left Hand Open Palm Facing Forward
and Pointing in Direction of Right Movement**

Slide # 13

Forks Hook Load Tophandler Up



Forefinger Extended, Pointed Up

Slide # 14

Forks Hook Load Tophandler Down



Forefinger Extended, Pointed Down

Slide # 15

Move Both Forks In, Closer Together or Tophandler 20' Position



Forefingers Extended and Pointed In

Slide # 16

Move Both Forks Out or Tophandler Out to 40' Position



Forefingers Extended and Pointed Out

Slide # 17

Move Forks, Load Right or Side Shift Tophandler Right



**Left Hand Pointed Forward with
Palm Facing In, Right Fist Closed
With Forefinger Pointed to Palm
of Left Hand**

Slide # 18

Move Forks, Load Left or Side Shift Tophandler Left



**Right Hand Pointed Forward With
Palm Facing In, Left Fist Closed
With Forefinger Pointed to Palm
of Right Hand**

Slide # 19

Hold Left Fork, Move Right Fork In



**Right Fist Closed, Left Forefinger Extended
and Pointed to Right Fist**

Slide # 20

Hold Right Fork, Move Left Fork In



**Left Fist Closed, Right Forefinger Extended
and Pointed to Left Fist**

Slide # 21

Hold Right Fork, Move Left Fork Out



**Left Fist Closed, Right Forefinger Extended
and Pointed Out**

Slide # 22

Hold Left Fork, Move Right Fork Out



**Right Fist Closed, Left Forefinger Extended
and Pointed Out**

Slide # 23

Oscillate Left Side Up, Right Side Down



**Left Hand Displaying the V-Sign and
Pointed Down. Right Hand Displaying
the V-Sign and Pointed Up**

Slide # 24

Oscillate Right Side Up Left Side Down



**Left Hand Displaying the V-Sign
and Pointed Up. Right Hand
Displaying the V-Sign and
Pointed Down**

Slide # 25

Tilt Load Out or Forks Up



**Left Hand Displaying the V-Sign
and Pointed Up. Right Hand
Pointed Up With Palm
Facing Forward**

Slide # 26

Tilt Load In or Forks Down



**Right Hand Displaying the V-Sign
and Pointed Up. Left Hand
Pointed Down With Palm Facing AFT**

Slide # 27

Lock Twistlocks or Hook Up Complete



Both Fist Facing Each Other

Slide # 28

Unlock Twistlocks or Unlock Load



**Both Hands Extended Pointing In,
Palms Facing Back**

Slide # 29

Level Load Level Forks Level Tophandler



**Right Hand Extended, Pointed In,
Palm Facing Down**

Slide # 30

Center and Level Load, Forks, or Tophandler



**Right Hand Extended, Pointed In,
Palm Facing Down, Left Hand Extended,
Pointing Up, Palm Facing In**

Slide # 31

Rotate Right End of Load, Tophandler or Forks Clockwise



**Rotate Right Hand Palm Up, Left Forefinger Extended
and Pointed in Direction of Movement**

Slide # 32

Rotate Left End of Load, Forks, or Tophandler Counter Clockwise



Rotate Left Hand Palm Up. Right Forefinger
Extended and Pointed in
Direction of Movement

Slide # 33

Characteristics of the RT 240 RTCH

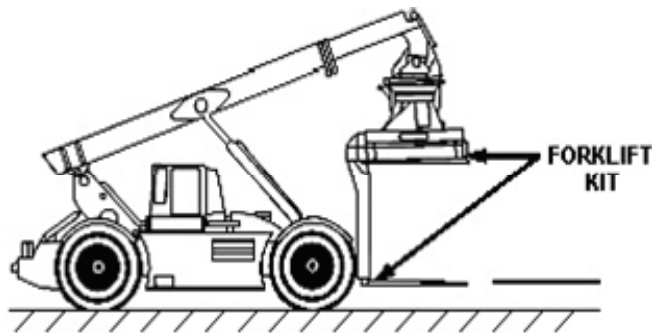

The RTCH can be used as a forklift. A kit is operator-installed and attached to the tophandler. The fork tines are adjustable from 24 inches center to center to 81.5 inches center to center. Lift capacity first stacking row is 44,000 pounds. Second stacking row is 24,600 pounds. Maximum lift height with forklift kit is 21.8 feet.

Slide # 34

Major Components

Left side view

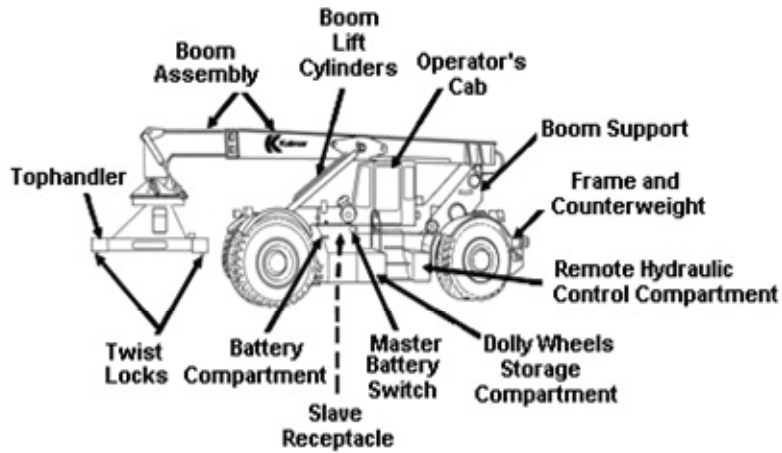

Slide # 35

Major Components

Right Side view

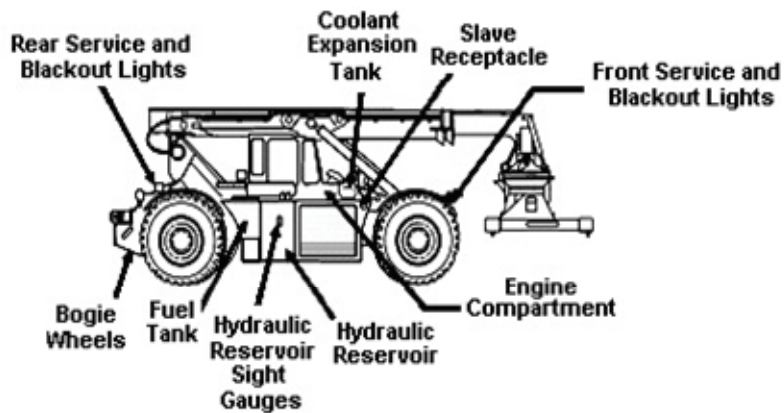

Slide # 36

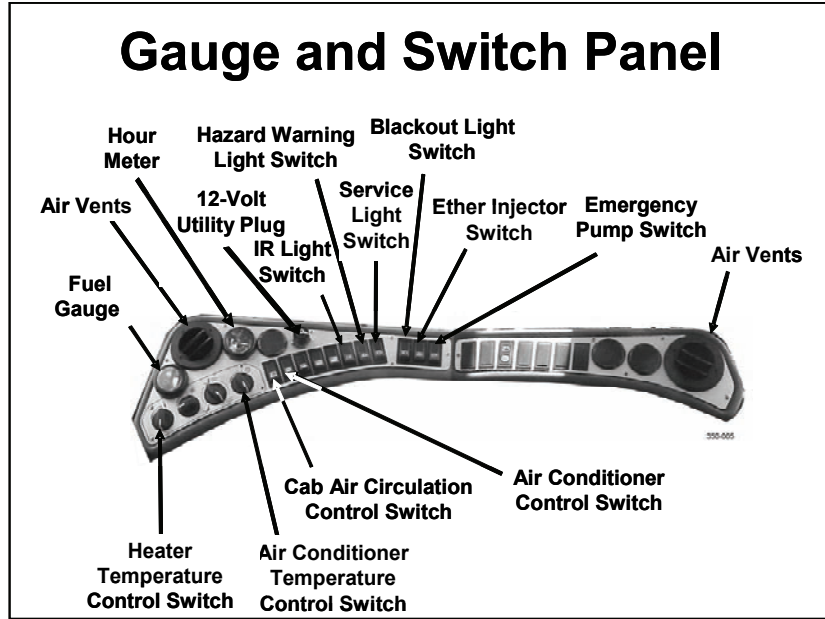

Slide # 37

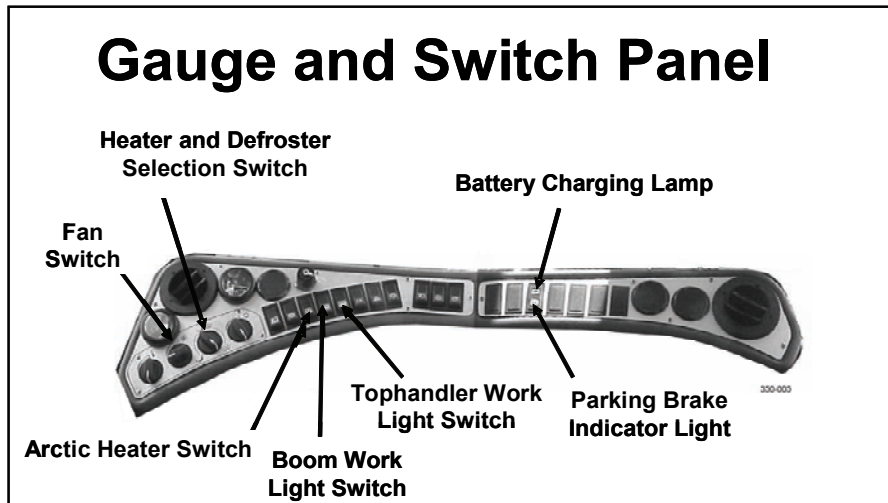

Slide # 38

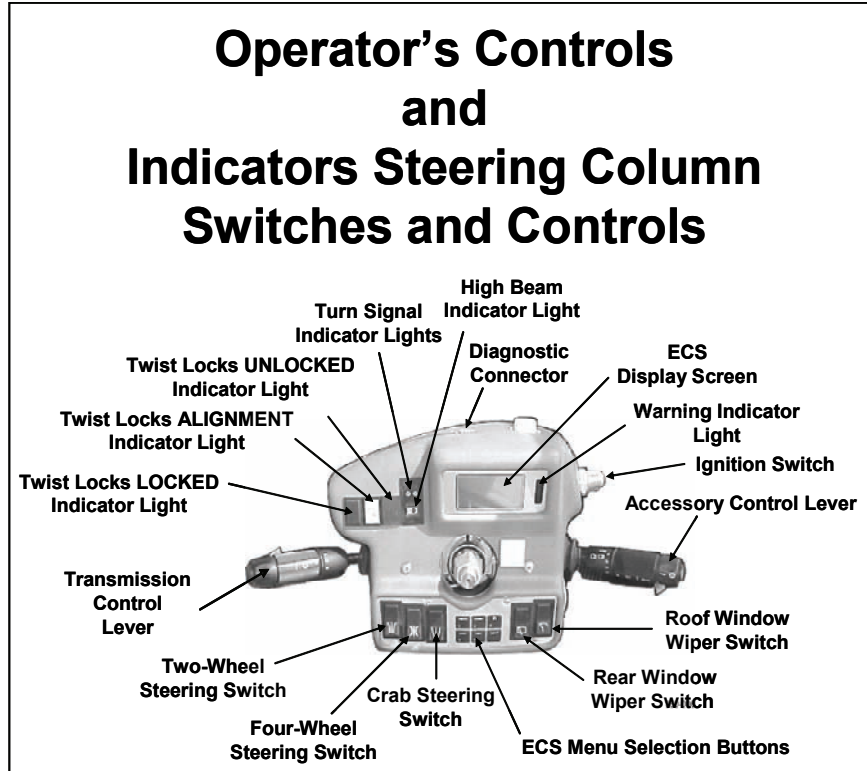

Slide # 39

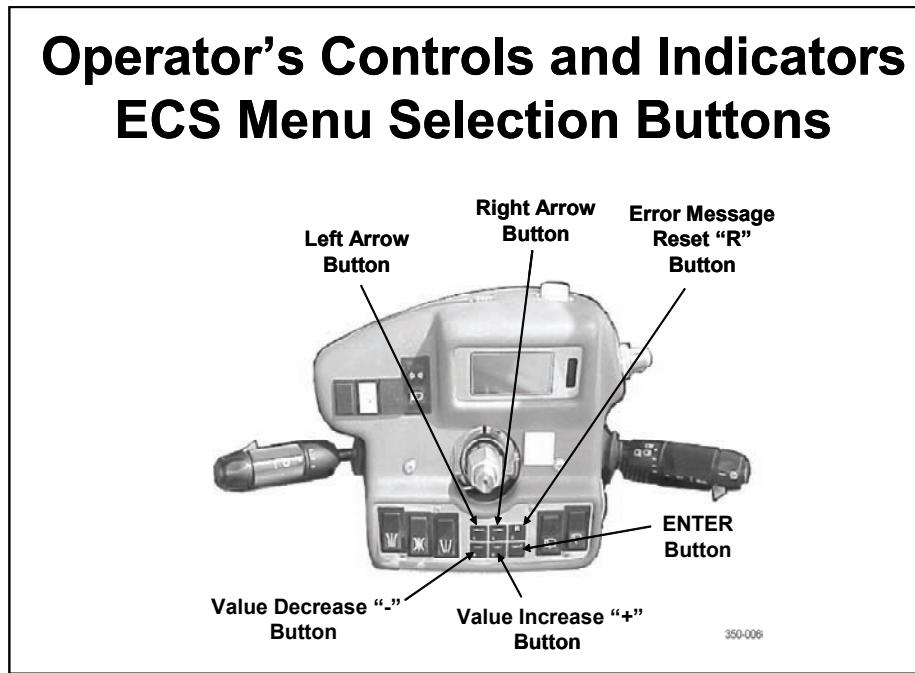

Slide # 40

Operator's Controls and Indicators Electronic Control System (ECS) Display Screens

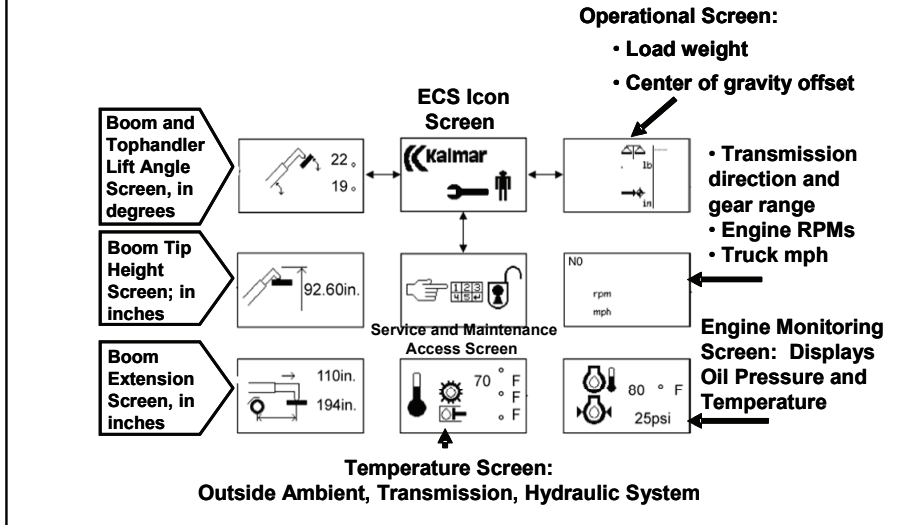

Slide # 41

Steering Wheel and Steering Column Controls

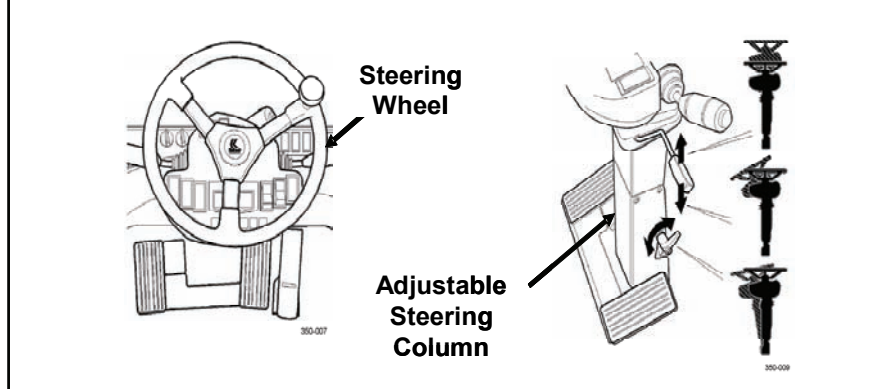

Slide # 42

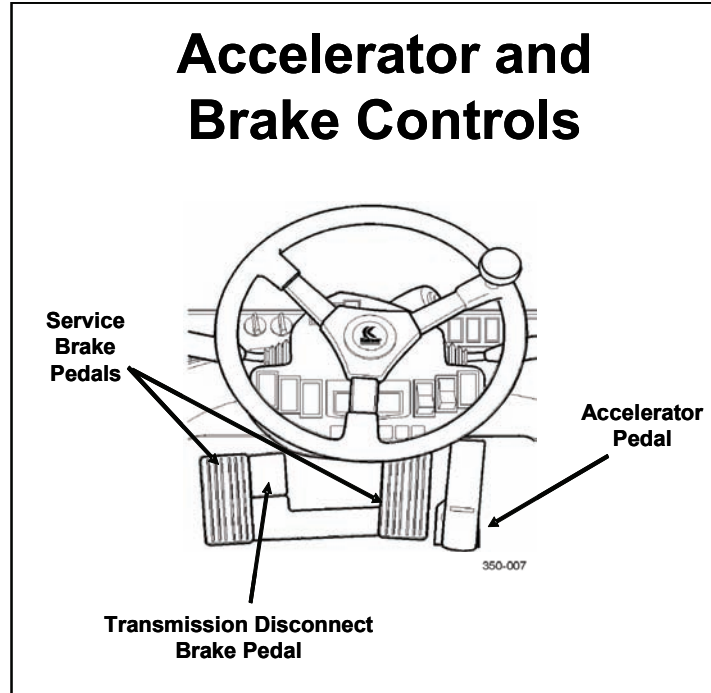

Slide # 43

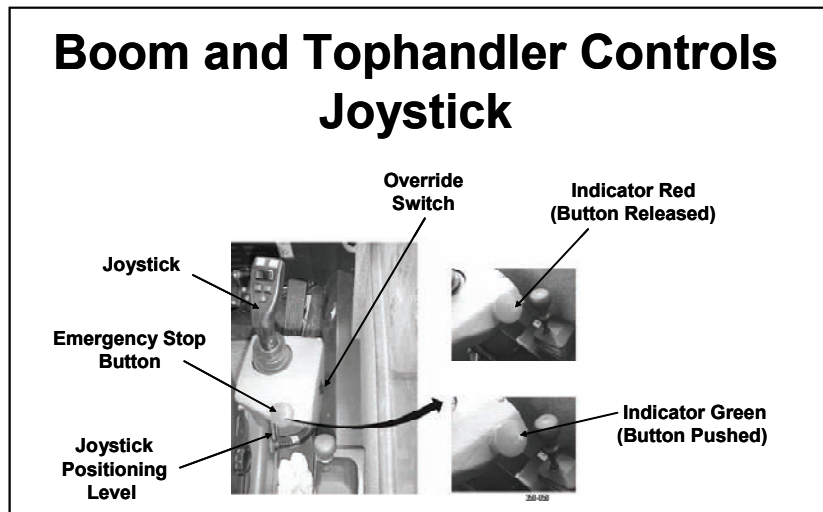

Slide # 44

Boom and Tophandler Controls

Twist Lock Indicator Lights

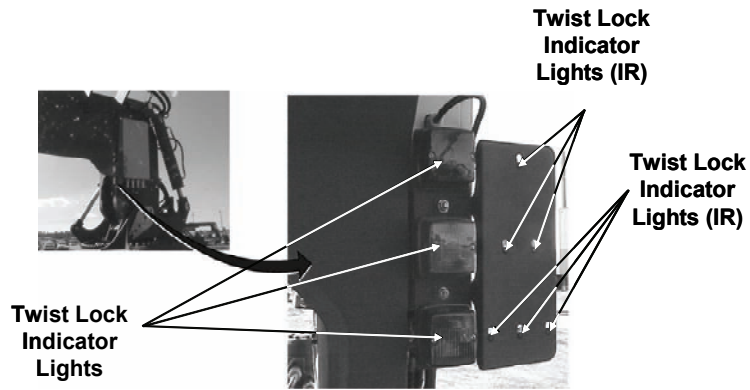

Slide # 45

Remote Hydraulic Controls

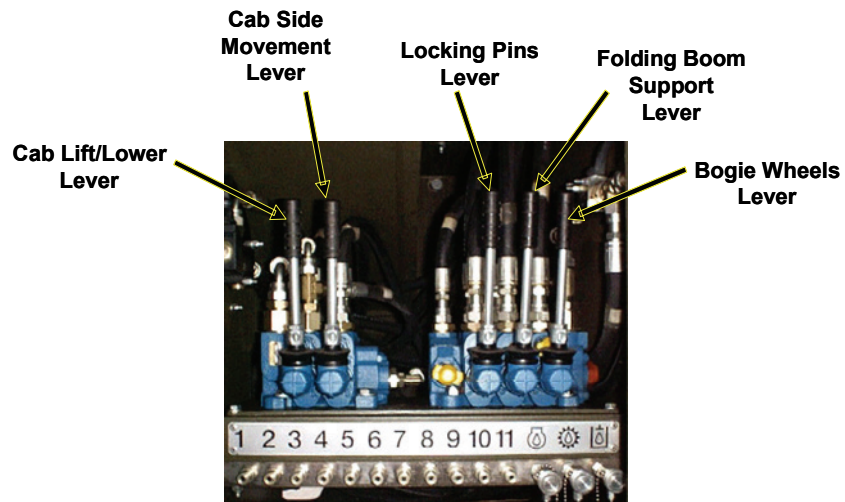

Slide # 46

Operation Under Usual Conditions

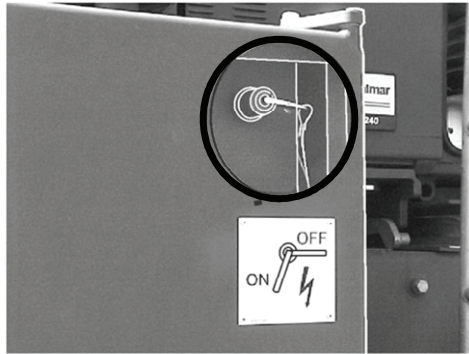

**Master Battery Switch
(shown in OFF position)**

350-048

Battery Switch - place master battery switch to ON

Slide # 47

Operate Parking Brake

**PARKING BRAKE LEVER
RIGHT SIDE OF SEAT**

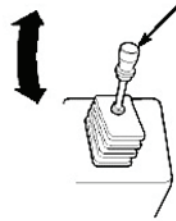

- Push the parking brake lever forward to engage the parking brake at front and rear axles. Raise release lever and pull the levers rearward to release the parking brakes.

- A RED indicator light will illuminate on the instrument panel when the parking brake is applied.

- A buzzer will sound if the driver attempts to leave the driver's seat without first applying the parking brake.

- After one emergency application using parking brake, notify organizational maintenance to replace parking brake pads.

- Do not apply parking brake when vehicle is moving. Bring to a complete stop.

WARNING

NEVER LEAVE THE OPERATOR'S POSITION WITHOUT APPLYING THE PARKING BRAKE. FAILURE TO FOLLOW THIS WARNING MAY RESULT IN DEATH OR INJURY TO PERSONNEL OR DAMAGE TO EQUIPMENT.

Slide # 48

Two-Wheel Steering

Press the two-wheel steering selection switch on the steering column.
Front wheels will steer in the direction the steering wheel is turned.
The rear wheels will remain in the forward position.

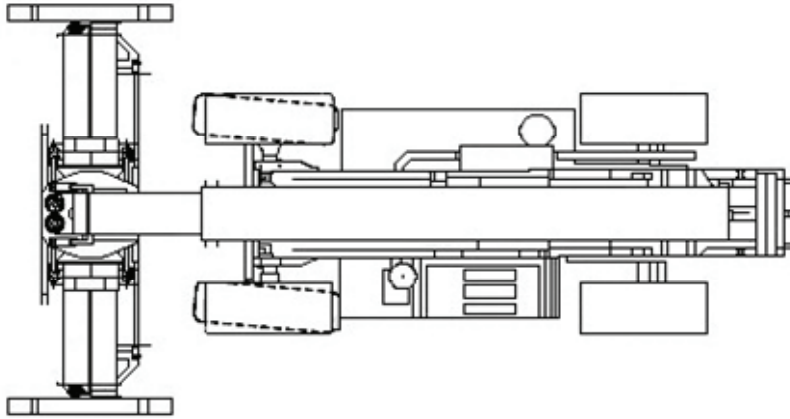

Slide # 49

Four-Wheel Steering

Press the four-wheel steering selection switch on the steering column.
Front wheels will steer in the direction the steering wheel; the rear wheels
will steer in the opposite direction. This steering mode allows for an
extremely short turning radius. It also enables the wheels to follow in the
tracks of the front wheels, thereby increasing traction in mud and snow
conditions.

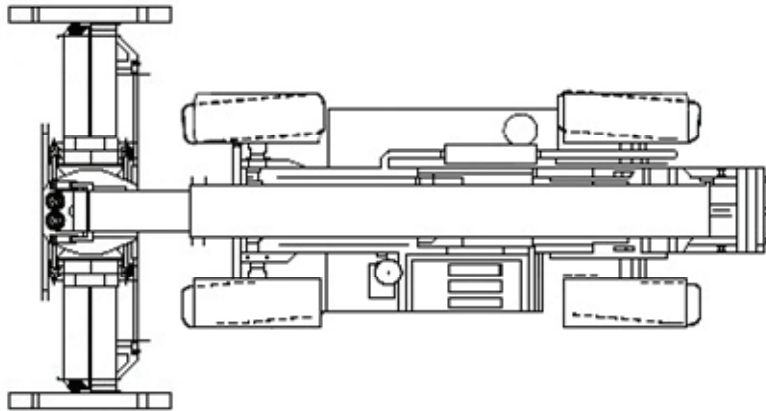

Slide # 50

Crab Steering

Press the crab steering selection switch on the steering column. All wheels will steer in the same direction. This steering mode permits sideways movement, for better positioning of the truck during transport and moving the truck within tight quarters.

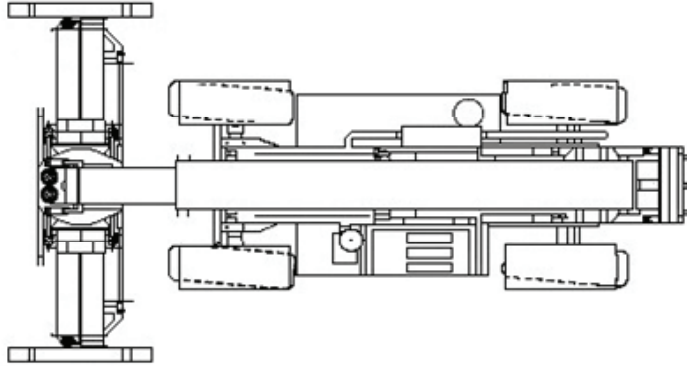

Slide # 51

Operate Transmission

TRANSMISSION CONTROL LEVER (SHOWN CENTERED IN NEUTRAL POSITION) LOCATION ON LEFT SIDE OF STEERING COLUMN

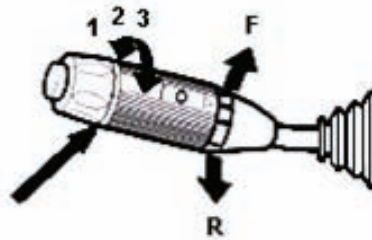







Select transmission-operating range

ALWAYS bring RTCH to complete STOP before changing from forward to reverse.

Slide # 52

2- or 4-Wheel Drive

- 2- or 4-wheel drive is controlled by the steering mode that is selected.
- When in 2-Wheel Steering, the ESC shifts the Transmission into 2-Wheel Drive.
- When in 4-Wheel or Crab steering the ESC shifts the Transmission into 4-Wheel Drive.

Gear Lever	Steering programs			
	Forward 	Four 	Crab 	Manual, Emergency Mode
F3	2-3-4	1-2-3	2	2
F2	2-3	1-2	1-2	1
F1	2	1	1	1
R1	2	1	1	1
R2	2	1-2	1	1
R3	2-3	1-2-3	1	2
				

Slide # 53

Operate Lifting Boom and Tophandler

- Joystick Operation. The buttons and switches on the joystick are used, individually or in conjunction with each other, to fully control all BOOM and TOPHANDLER operations.
- The decal, located on the cab's right-side window, summarizes all joystick functions.

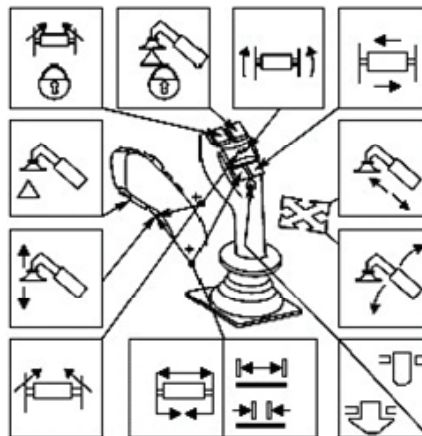

Slide # 54

Boom Control Handle (Joystick)

- Move control handle forward to lower boom
- Move control handle back to raise boom
- Move control handle right to extend boom
- Move control handle left to retract boom

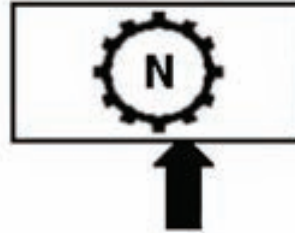

RT 240 V2: The transmission will shift to neutral automatically if the container is not lifted off the ground before trying to drive. This popup icon will display during this condition. Pressing "R" (Reset) will delete the icon from the display. The container must be lifted off the ground before the transmission will re-engage.



Slide # 55

Tophandler Operational Envelope

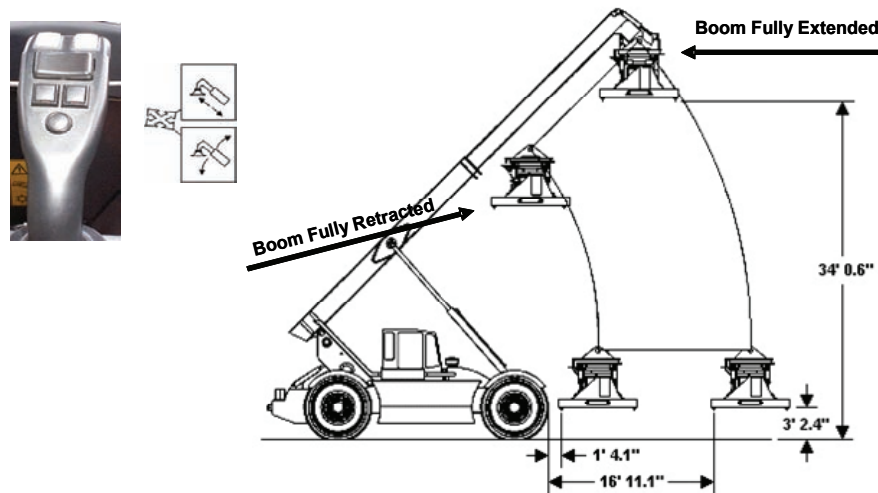

Slide # 56

Multiple Function Trigger

The multiple function trigger button allows two functions to be performed at the same time or allows one button to perform two tasks.

Multiple Function Trigger
is the lower button



When using the Multiple Function Trigger,
it must be engaged first

Slide # 57

Straight Lift/Lower Controls

- Move control handle back while pressing multiple function trigger button to raise and extend boom.
- Move control handle forward while pressing multiple function trigger button to lower and retract boom.

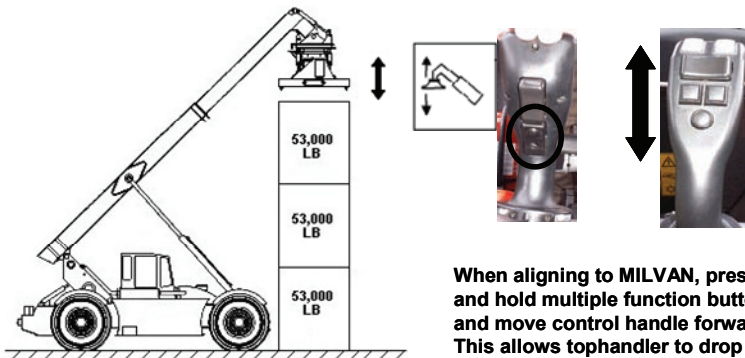

When aligning to MILVAN, press
and hold multiple function button
and move control handle forward.
This allows tophandler to drop
straight down onto the MILVAN.

Slide # 58

Tophandler Rotating Positions

WARNING

WHEN ROTATING TOPHANDLER, IT WILL HIT THE TIRES AND FENDERS. WITH BOOM RAISED, IT WILL HIT THE BOOM.

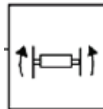
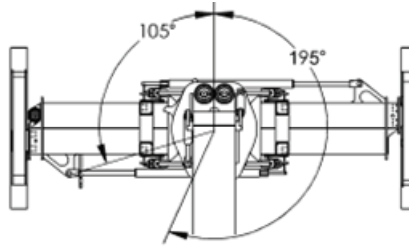

Rotation Control Rocker Switch

Press left side of rocker switch to rotate load clockwise.

Press right side of rocker switch to rotate load counterclockwise.

Slide # 59

Tophandler Rotating Positions RT 240 V2

- To minimize damage from boom, tophandler, and container contact, the tophandler rotation is limited to 40 degrees clockwise or counterclockwise from the operational position if the boom angle is above 15 degrees.
- The full rotation of 105 degrees clockwise or 40 degrees counterclockwise can be obtained if the boom angle is under 15 degrees.
- The lift function will be stopped at 15 degree boom angle if lifting a tophandler that is rotated more than 40 degrees clockwise.

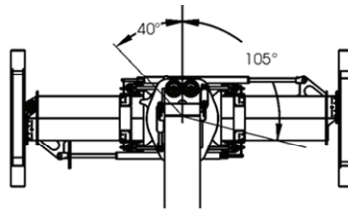

- When the tophandler is rotated more than 40 degrees clockwise, the tilt "bottom in" function is limited..
- The tilt function is controlled in order to reduce the possibility of boom and tophandler contact..

The following popup icon will display during this condition. Pressing "R" (Reset) will delete the icon from the display.

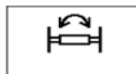

The following popup icon will display during this condition. Pressing "R" (Reset) will delete the icon from the display.



Slide # 60

Container Oscillation Angles

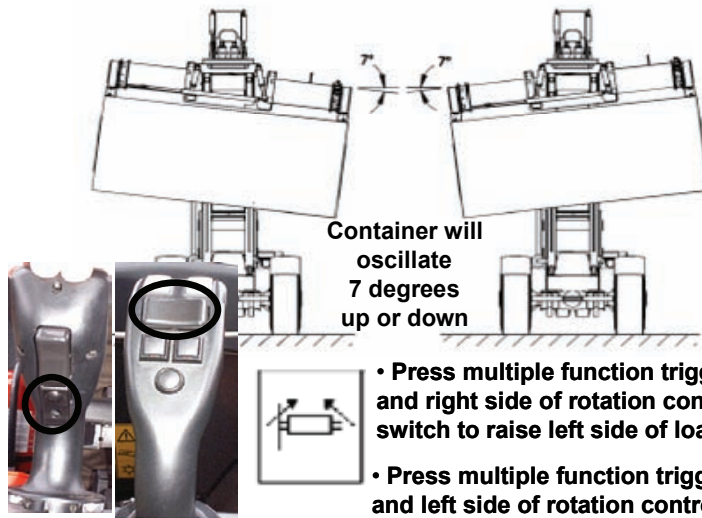

Container will oscillate 7 degrees up or down

- Press multiple function trigger button and right side of rotation control rocker switch to raise left side of load.
- Press multiple function trigger button and left side of rotation control rocker switch to raise right side of load.

Slide # 61

Tophandler Shifting Positions

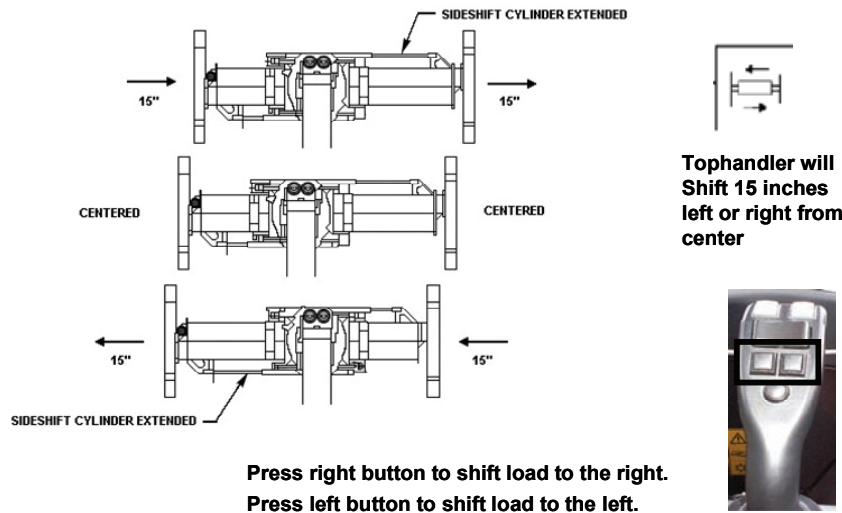

Tophandler will Shift 15 inches left or right from center

Press right button to shift load to the right.
Press left button to shift load to the left.

Slide # 62

Tophandler Lift Positions



40' CONTAINER LIFT POSITION

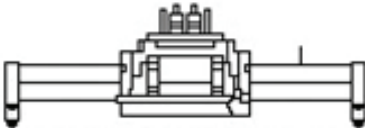

20' CONTAINER LIFT POSITION

Press multiple function trigger and right button to widen tophandler from 20 to 40 feet or to open forklift times, if forklift is installed.

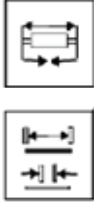
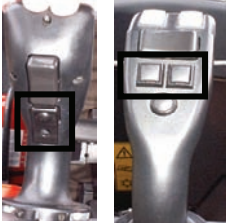



Slide # 63

Container Tilt Angles

WARNING

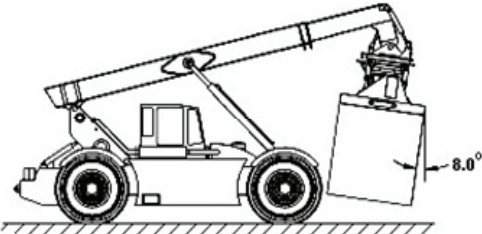
CONTAINER CAN AND WILL HIT THE TIRES AND FENDERS.



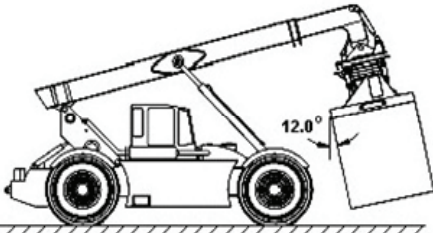

8.0°



12.0°

Tilt Control is the Upper Switch

Press top of rocker switch to tilt bottom of load out.

Press bottom of rocker switch to tilt bottom of load in.

Slide # 64

Positioning Tophandler Over MILVAN

Fully lower the tophandler while aligning the twistlocks with the container locking holes.

When twistlocks are unlocked, RED indicator light on steering column inside cab and at end of boom will illuminate.

Single IR light at end of boom also illuminates, when operating in blackout mode.

MILVAN

- Press button to lock twistlocks, securing load.
- Press button to unlock twistlocks, releasing load.

Slide # 65

Tophandler Positioning

IR Lights

- Check that the **YELLOW** alignment indicator light is on. This indicates the twistlocks are engaged in all four locking holes of the container.
- Lock the twistlocks.
- Check that the **GREEN** lock indicator light is on and the **RED** is off.
- Lift the load. When load is lifted, the **YELLOW** alignment indicator light will go out.

NOTE

Pressing twistlocks lock/unlock button and override switch at the same time will lock out or disable boom lifting and lowering operation; twistlocks indicator light will turn off. To reactivate boom, momentarily press twistlocks lock/unlock button and override switch at the same time.

Slide # 66

Joystick Operation

Oscillation Lock/Unlock Button

Press to engage lock, securing load position.
Press to release lock, allowing load to float.

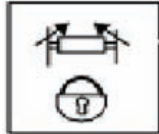

NOTE – Button illuminates when lock is engaged.

Must be locked before traveling with load.

Slide # 67

Joystick Operation

Tilt Lock/Unlock Button

Press to engage lock, securing load position.
Press to release lock, allowing load to float.



NOTE - Button illuminates when lock is engaged.

Must be locked before traveling with load

Slide # 68

Container Positioning for Travel

Lifting and Centering 20-foot or 40-foot Containers

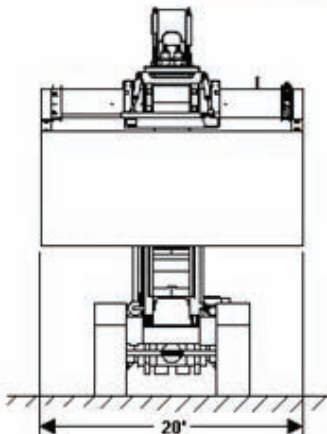

Center and level the load

Always position the bottom of the load just above driver's field of view, 340 inches with the BOOM FULLY RETRACTED.

Engage oscillation and tilt locks before driving with a load.



Oscillation Lock





Tilt Lock

Slide # 69

Container Positioning

Lifting and Centering 40-foot Containers, same as the 20 foot

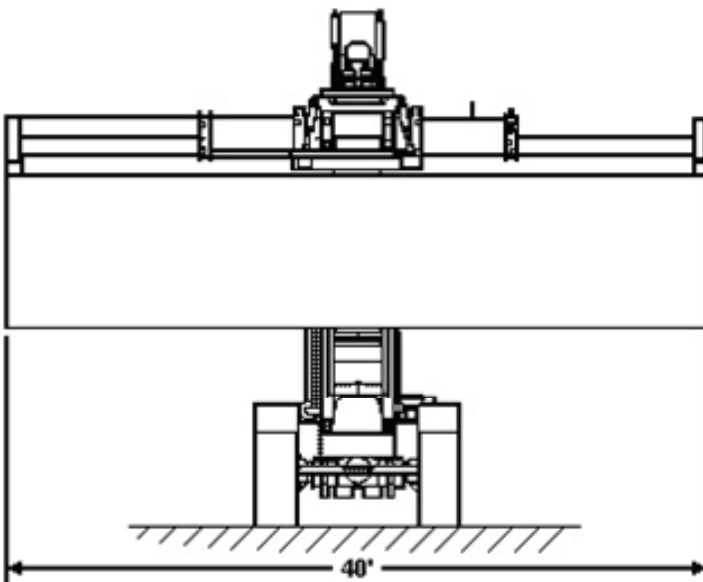

Slide # 70

Joystick Override Switch

- Press override switch in the event of incorrect twistlocks alignment, locked or unlocked signals.
- Allows the operator to lower the boom after an OVERLOAD lockout.
- Allows the boom to be raised when tophandler is removed.

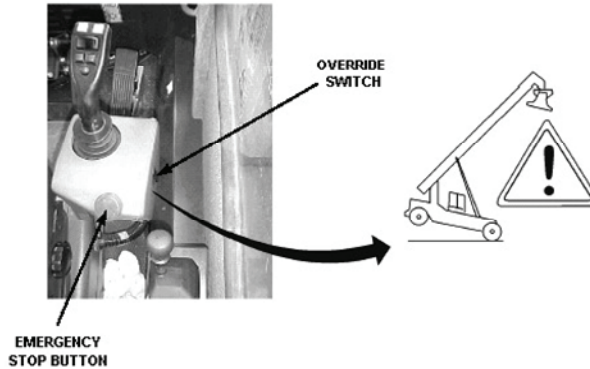

Slide # 71

Joystick Override Switch

Pressing twistlocks lock/unlock button and override switch at the same time will lock out or disable boom lifting and lowering operation; twistlocks indicator light will turn off. To reactivate boom, momentarily press twistlocks lock/unlock button and override switch at the same time.

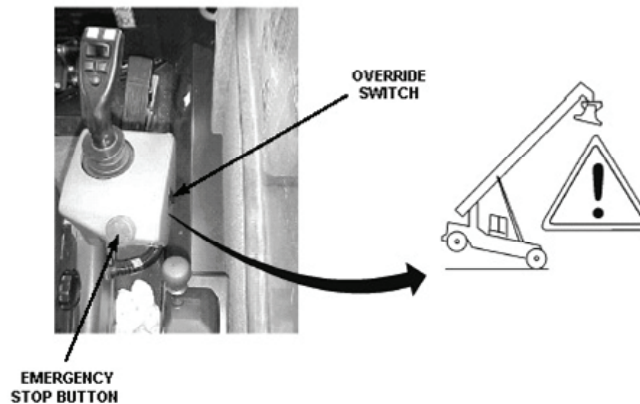

Slide # 72

Joystick Emergency Stop Button

- Press button to stop all boom and tophandler hydraulic functions
- Be sure to release emergency stop button when resuming normal operation. If emergency stop button is left activated, error codes may appear on ECS drive's display screen.
- Pull button to release emergency stop button.

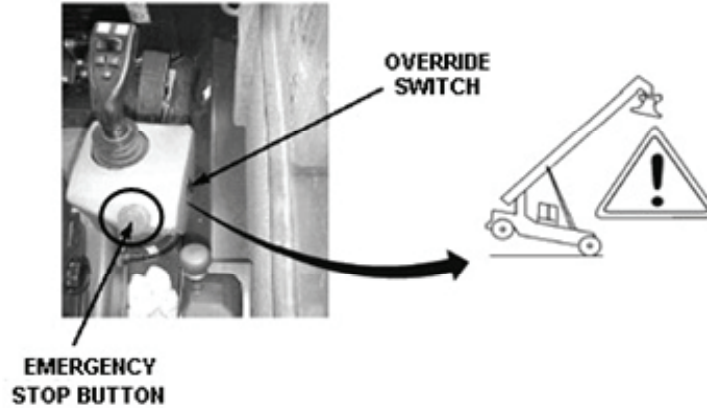

Slide # 73

Container Reach and Load Range

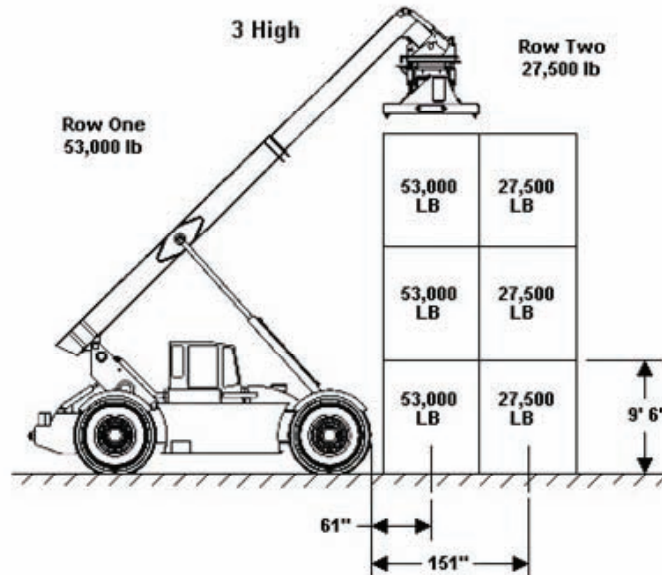

Slide # 74

Explanation of Table Entries



ITEM NO.	INTERVAL	LOCATION	PROCEDURE	NOT FULLY MISSION CAPABLE IF:
		ITEM TO CHECK/ SERVICE		

- **Item Number (Item No.) Column.** Numbers in this column are for reference.
- **When completing DA Form 5988-E or DA Form 2404 (Equipment Inspection and Maintenance Worksheet), include the item number for the check/service indicating a fault.**
- **Item numbers also appear in the order that you must perform checks and services for the interval listed.**

Slide # 75

Interval Column



ITEM NO.	INTERVAL	LOCATION	PROCEDURE	NOT FULLY MISSION CAPABLE IF:
		ITEM TO CHECK/ SERVICE		

- **Before procedures must be done immediately before you operate the truck.**
- **During procedures must be done while you are operating the truck.**
- **After procedures must be done immediately after you have operated the truck.**
- **Weekly procedures must be done once each week.**
- **Monthly procedures must be done once a month.**

Slide # 76

Location, Item to Check or Service



ITEM NO.	INTERVAL	LOCATION		PROCEDURE	NOT FULLY MISSION CAPABLE IF:
		ITEM TO CHECK/ SERVICE			

ITEM NO.	INTERVAL	LOCATION	
		ITEM TO CHECK/ SERVICE	
6	Before	REAR AND RIGHT SIDE	
		<u>Overall View</u>	
7	Before	Hydraulic Cylinders	
8	Before	Boom Support Locking Pin	

This column provides the location and item to be checked or serviced.

• The item location is underlined.

Slide # 77

Procedure Column



ITEM NO.	INTERVAL	LOCATION		PROCEDURE	NOT FULLY MISSION CAPABLE IF:
		ITEM TO CHECK/ SERVICE			

a. Check under truck for evidence of fluid leakages such as oil, coolant or hydraulic fluid.
 b. Visually check for damaged tires. Check for missing or signs of loose lug nuts.

• This column gives the procedure you must perform to check or service the item listed in the Item to Check/Service column to know if the equipment is ready or available for its intended mission or for operation.

• You must perform the procedure at the time stated in the interval column.

Slide # 78

Not Fully Mission Capable If: Column

ITEM NO.	INTERVAL	LOCATION	PROCEDURE	NOT FULLY MISSION CAPABLE IF:
		ITEM TO CHECK/SERVICE		



- Information in this column tells you what faults will keep your equipment from being capable of performing its primary mission.
- If you perform check/service procedures that show faults listed in this column, the equipment is not mission-capable.
- Follow standard operating procedures for maintaining the equipment or reporting equipment failure.

Slide # 79

PMCS for RTCH-RT 240

5 - Before Boom Support Locking Pin

- Ensure that boom support locking pin is present and extension is locked by retaining pin in extended position. Boom support locking pin is missing, extension is not locked in extended position or is damaged.

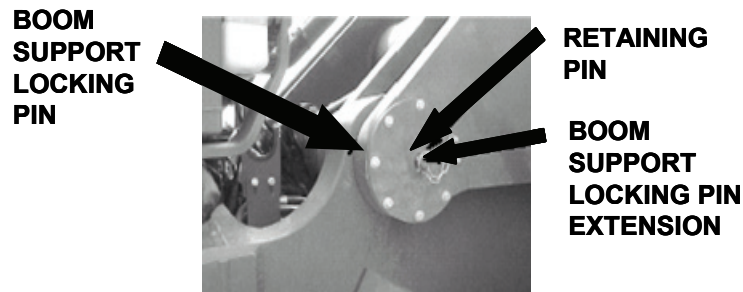

Slide # 80

PMCS for RTCH-RT 240

9 – Before Hydraulic Reservoir and Sight Gauge

Check for damage and leaks

FILL POINT

If hydraulic oil is Visible in sight Gauge, level is Okay. If level is Low, add oil in Accordance with Instructions in LO 10-3930-675-12.

HYDRAULIC RESERVOIR

SIGHT GAUGE

Boom must be fully lowered and retracted and truck on level ground before checking hydraulic oil level in reservoir. Engine should be stopped at leave five minutes.

Slide # 81

PMCS for RTCH-RT 240

12 – Before Twistlocks

Visually check all twistlocks, hydraulic cylinders, electrical wiring, and switches for signs of damage.

TWISTLOCK

HYDRAULIC LINES

HYDRAULIC CYLINDER

SWITCH

TWISTLOCK

Slide # 82

PMCS for RTCH-RT 240

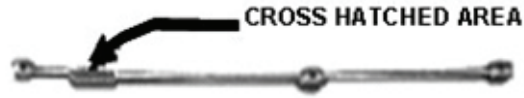

#13 – Before Engine Oil Level

- Check engine oil level on dipstick. Maintain oil level within cross hatched area at end of dipstick. If level is low, add oil in accordance with LO 10-3930-675-12.

Wait 10 minutes after shutting down engine to allow oil to drain into crankcase.

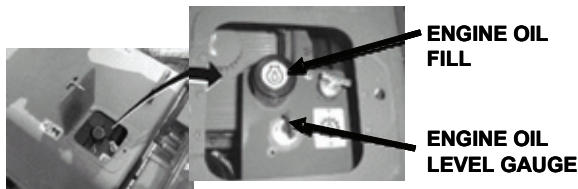

To ensure an accurate reading, vehicle must be parked on level ground.

Slide # 83

PMCS for RTCH-RT 240

Checking coolant level in expansion tank

Level should be between the MIN and MAX lines on tank.
Add coolant as required.

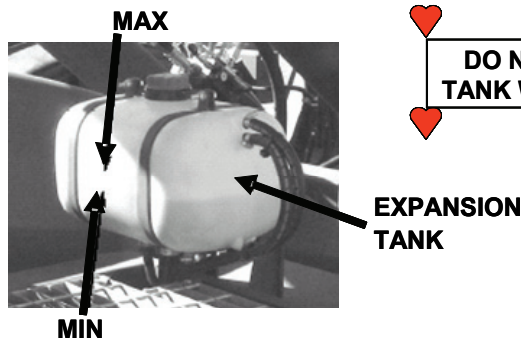

Slide # 84

PMCS for RTCH-RT 240

INDICATOR MARKS



#35 – After Transmission Oil Level

- With engine idling, transmission selector lever in N, parking brake set, and engine at operating temperature (coolant temperature of 180 degrees Fahrenheit [82 degrees Celsius] minimum), remove transmission dipstick.
- Level as indicated on dipstick should be maintained within two indicator marks at end of dipstick.
- If level is low, add transmission fluid in accordance with LO 10-3930-675-12.

Slide # 85

PMCS for RTCH-RT 240

#35 – After Transmission Oil Level

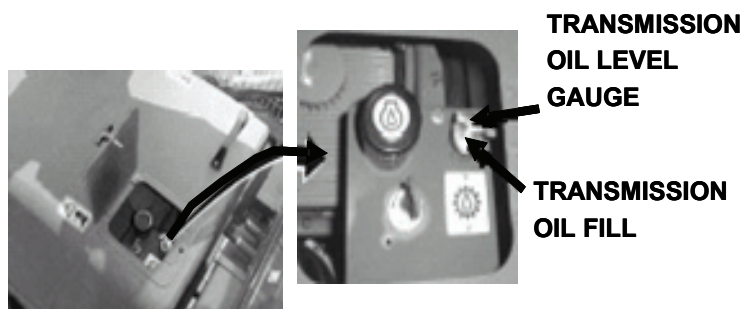

Slide # 86

PMCS for RTCH-RT 240

#46 – Weekly

Fuel/Water Separator

- Turn drain knob counterclockwise and drain all water from fuel/water separator.

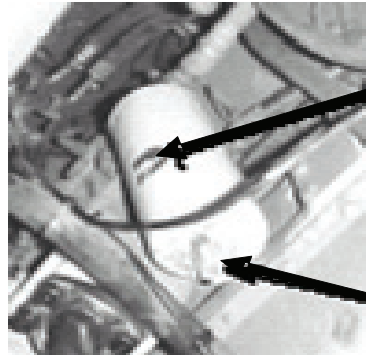

FILTER, FUEL /
WATER SEPARATOR

DRAIN KNOB

Slide # 87

PMCS for RTCH-RT 240 Engine Air Cleaner Servicing



Perform service only if
indicator shows red

Dust vent may be squeezed 2 to 3 times while engine is running
to evacuate dust from air cleaner.

Slide # 88

Engine Air Cleaner Servicing

FILTER ELEMENT

Open six spring clips and remove cover from end of engine air cleaner

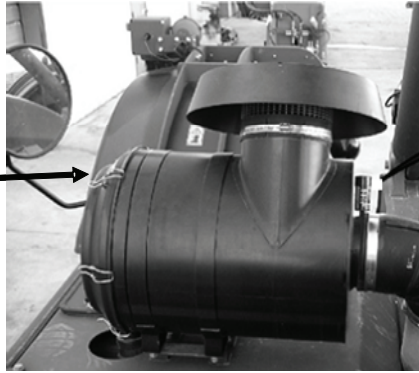

Slide # 89

Filter Element

- Remove primary filter element from air cleaner

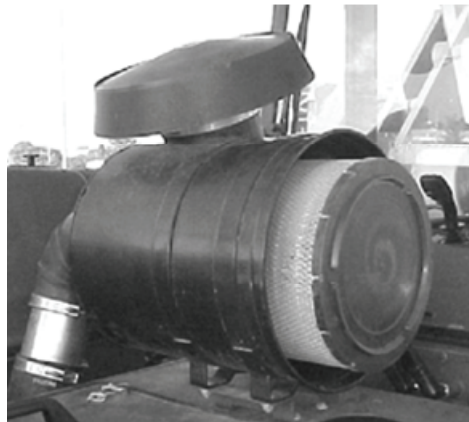

Slide # 90

Filter Element

- Remove secondary filter element from air cleaner.
- Using rags, wipe interior of air cleaner free of dust and dirt.
- Clean filters with air.

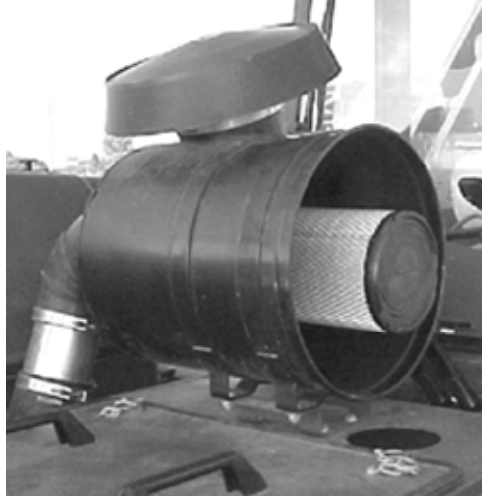

Slide # 91

Relieving Hydraulic System Pressure

- To release pressure in brake hydraulic system, open two brake accumulator evacuation valves behind cab.
- Allow pressure to release, approximately 15 seconds. It is now safe to perform maintenance on brake system.

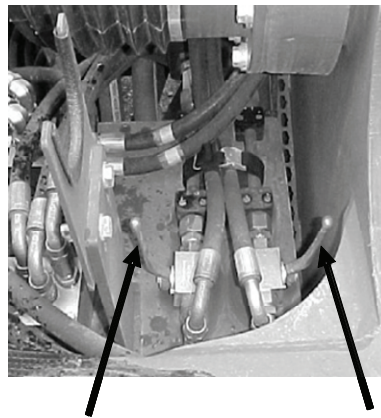

Slide # 92

Relieving Hydraulic System Pressure

- To release pressure in boom hydraulic system (boom extension and lift cylinders, hoses, pipes, and valves), open float control valve and emergency control valve on each locking valve at base of each lift cylinder.

- Leave valves open until maintenance action is completed, then close valves before starting engine to pressurize system.

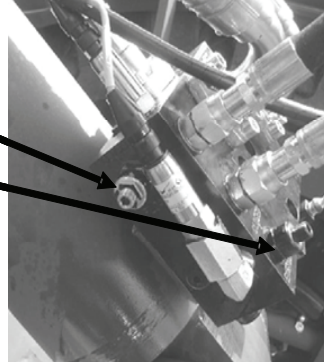

Slide # 93

Relieving Hydraulic System Pressure

- When disconnecting hydraulic lines from boom folding cylinders, additional precautions are required due to residual pressure in lines:

- Wear eye protection.
- Have a rag handy and slowly disconnect hydraulic lines.



Slide # 94

Caging

- Remove cover.
- A strap wrench may be required to remove cover.

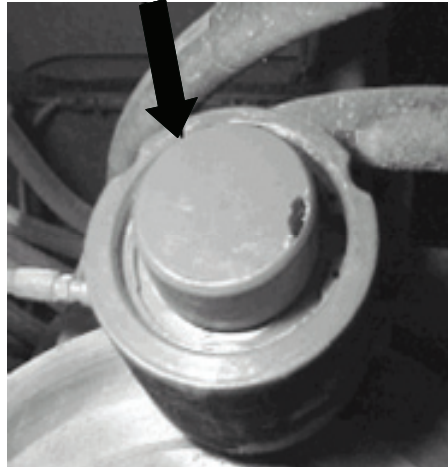

Slide # 95

Caging

- Loosen jam nut.
- Loosen adjusting screw until brake disk pad moves freely.

Hand tighten jam nut.
Reinstall cover.

The RTCH can now be
safety towed.

Parking Brake Cover

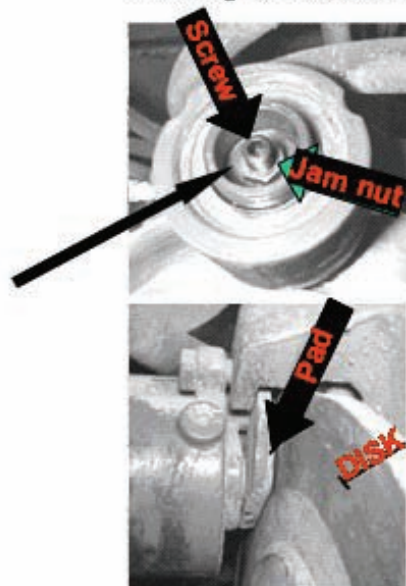

Slide # 96

RTCH - RT 240

LUBRICANT - INTERVAL

RTCH-RT 240 LUBRICANT-INTERVAL

1 of 4 Charts for Operator/Crew Lubrication Order

Operator/Crew Lubricate points is Indicated by (C)

INTERVALS
D – Daily
W – Weekly
HR – Hours
OC – On Condition

Component	Lubricant	Interval
Tophandler Hydraulic Stewing Motors Check Level (C) Fill or Change (O) (Note 15 and View G)	OE/HDO 10/GO	Weekly 1000 hr
Tophandler Pivot Pins One Fitting Each (C)	GAA	200 hr
Tophandler Hydraulic Spreader Motor Check Level (C) Fill or Change (O) (Note 16 and View H)	OE/HDO 10	Weekly 1000 hr
Front Axle Steering Cylinder Two Fittings (C)	GAA	200 hr
Front Propeller Shaft and Universal Joints Three Fittings (C)	GAA	200 hr
Cab Door Hinge Pin Two Fittings (C)	GAA	1000 hr
Boom Support Locking Pins (Note 17)	GAA	200 hr
Boom Support Pivot Pins One Fitting Each (C)	GAA	200 hr
Lifting Boom Pivot Pins (C) (One Fitting Each)	GAA	200 hr
Bogie Wheel Cylinder Four Fittings (C)	GAA	200 hr
Bogie Wheel Frame One Fitting (C)	GAA	200 hr
Bogie Wheel Axle One Fitting Each Side (C)	GAA	200 hr
Pintle Hook Two Fittings (C)	GAA	200 hr

Dashed lines indicate lubrication points on BOTH sides of vehicle.

NOTE
DO NOT lubricate boom and tophandler wear plates.

Slide # 97

On-board Computer Error Code Display and Error Codes

350-008

The RTCH has an extensive on-board diagnostic capability that enables the user to isolate faults based on error codes. This diagnostic capability, when used in conjunction with traditional troubleshooting techniques, enables the user to fault isolate most malfunctions that will occur on the RTCH.

Slide # 98

Error Code Display Screen

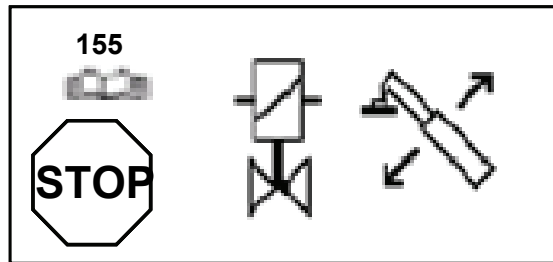

Common malfunctions which may occur will be detected by one of the six computers on board and displayed on driver's Electronic Control System (ECS) screen.

When an error code appears on driver's display screen during operation, the operator must know how to read and what actions should be taken.

Slide # 99

Error Code Display

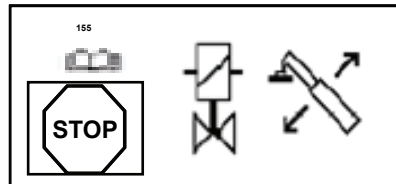

- These error codes are visible to both the driver and the maintainer and address very specific equipment conditions on the vehicle.

- This error code listing also addresses required driver actions based on the category and type of error identified.

- There are three kinds of information in the Electronic Control System (ESC) display.

Icons in the left lower corner of the display describe what the driver actions are.

Slide # 100

Driver Actions

**STOP VEHICLE IMMEDIATELY
in a safe way**

- Can be a safety issue
- Machine performance may be restricted.
- Read operator's manual for instructions.

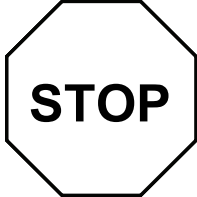

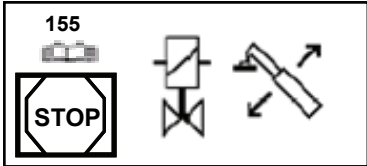

Slide # 101

Driver Actions

- **WARNING – DEGRADED OPERATION**
- Stop vehicle in a safe way.



- Read operator's manual for instructions.
- Contact maintenance personnel.
- Confirm that error message is acknowledged by pressing the **RESET** button.
- Error will appear every three minutes as long as error is active.
- It can be reset every time it shows.

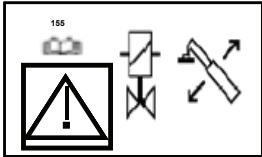

Slide # 102

Type of Fault

Icons in the center of the display identify the type of fault. There are five fault types used.

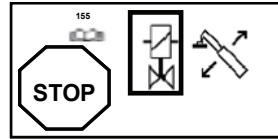

ICON	DESCRIPTION		ICON	DESCRIPTION
	Sensor			Lever
	Value			Temperature
	Pressure			

Slide # 103

Function or Vehicle Fault

Icons in the right of the display identify what function or vehicle system the fault is related to. This table lists the various functions or vehicle systems used in the display.

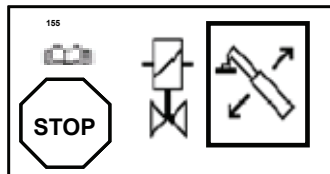

ICON	DESCRIPTION	ICON	DESCRIPTION
	Battery		Twistlock
	Forklift kit		Up/Down
	Emergency stop or battery		In/Out
	Rotation		Transmission
	Hydraulic filter		Fan
	Communication		Engine

Slide # 104

Error Code Number

Number in the upper left corner of the display is the TM 10-3930-675-10 Operator's Manual error code category number.

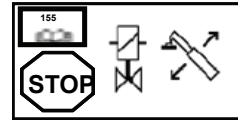

TM 10-3930-675-10

ERROR CODES - CONTINUED

0020 00

Table 4. Error Codes - Continued.

ERROR CODE	DISPLAY LAYOUT	DRIVER ACTION	ERROR CODE CATEGORY/ EXPLANATION	VEHICLE LIMITATIONS
141		Finish Mission Shut engine off/on. If code clears, resume mission. If code remains, notify maintenance.	Information/Maintenance Communication fault - ECU 790 Computer hardware fault.	Possible ECU malfunction. Other codes will also show.
142		Finish Mission Shut engine off/on. If code clears, resume mission. If code remains, notify maintenance.	Information/Maintenance Communication fault - ECU 790 Computer hardware fault.	Possible ECU malfunction. Other codes will also show.
151		Stop Vehicle Put load down safely. Abort mission. Notify maintenance.	Stop Vehicle Immediately Locking valve, broken circuit Cable to valve defective.	Boom cannot be lowered with joystick. Emergency lowering is necessary.

Slide # 105

ENGINE DERATE ERROR CODES

RT-240 V2

ENGINE PROTECTION CODES; 1143,1151,1155,1234 AND 1415 WILL DERATE THE ENGINE TO 1000 RPMS AND SHUT THE ENGINE DOWN AFTER 30 SECONDS.



ALL STOP TYPE ERROR CODES; ANY ERROR CODE THAT APPEARS WITH THE STOP SIGN SYMBOL WILL DERATE THE ENGINE TO 1000 RPMS. THE DERATE CAN ONLY BE CLEARED BY TURNING OFF THE ENGINE AND RESTARTING.



Slide # 106

Approaching MILVAN for Pick Up

Raise tophandler high enough to clear top of MILVAN and approach slowly.



NEVER OPERATE THE RTCH OR MOVE THE LOAD NEAR A POWERLINE OR OVERHEAD WIRES.

Slide # 107

Approaching MILVAN for Pick Up

There is two ways to align on a MILVAN for pick up.

Pick out a center rib on MILVAN.



Align white line on the tophandler with rib on MILVAN move forward slowly keeping aligned.

Slide # 108

Approaching MILVAN for Pick Up

Using center rib on MILVAN, align center of valve guard between hydraulic hose with center rib.

Adjust the tophandler spreader width (20 to 40 feet) for the container to be lifted.

DURING LIFTING OPERATION, DO NOT EXCEED THE MAXIMUM LIFTING CAPACITY.



Slide # 109

Approaching MILAN for Pick Up

Move RTCH forward as close as possible to the container, until wheels are approximately 12" to 18" from MILVAN.

If using headlight guard, approximately 20" to 24".

APPLY PARKING BRAKE
PLACE TRANSMISSION
LEVER IN NEUTRAL



TRANSMISSION DISCONNECT SHOULD NOT BE USED DURING PICK UP

Slide # 110

Transmission Disconnect

**Transmission disconnect
brake pedal location.**

**Depress to release
transmission internal
clutch.**

**This allows the
operator to increase
engine RPM,
thereby
accelerating
hydraulic functions.**

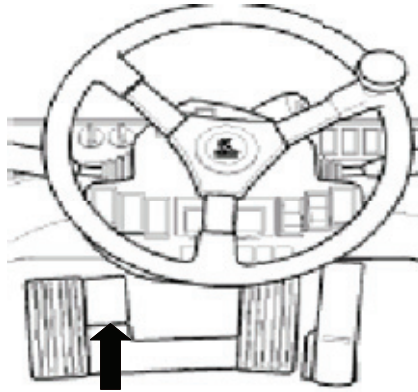

**TRANSMISSION DISCONNECT SHOULD BE USED FOR
A SHORT TIME ONLY**

Slide # 111

Joystick Control Buttons

**Tilt and oscillation should be locked
to secure the tophandler movement
during hook up of MILVAN.**

**BUTTONS ILLUMINATES
WHEN LOCK IS ENGAGED**

**Do not perform container handling
procedures while in blackout mode.
Blackout mode is to be used only
when driving. In blackout mode,
oscillation and tilt lock/unlock
buttons do not illuminate.**



Slide # 112

Tilt Control



**TOP OF SWITCH
TILTS OUT**

**BOTTOM OF SWITCH
TILTS IN**

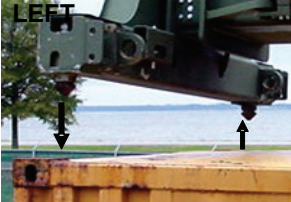

LEFT

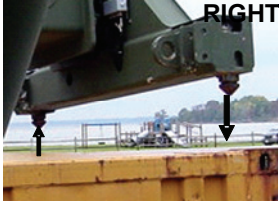

RIGHT

Use tilt control switch to level fwd and aft twistlocks with top of MILVAN.

Slide # 113

Oscillation



Use oscillating controls to adjust right and left twistlocks the same distance from MILVAN.



Press multiple function trigger and rotation control rocker switch for oscillation movement.

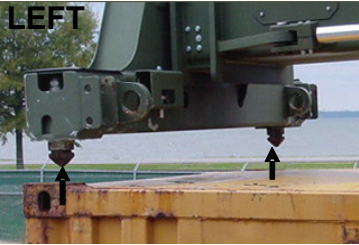

LEFT

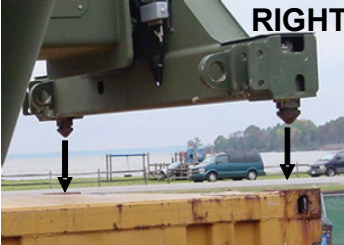

RIGHT

Slide # 114

Boom Control

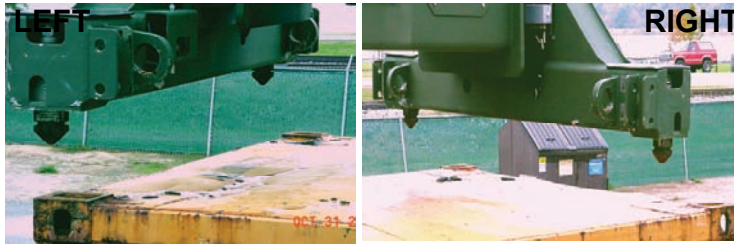

Use joystick to align twistlocks with the container locking holes by extending or retracting boom.

Raise or lower boom until twistlocks are approximately 4" x 6" from top of MILVAN.



Slide # 115

Rotation Control

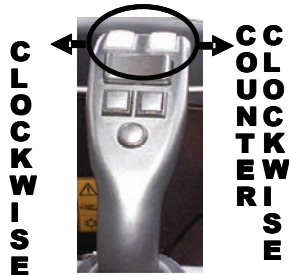

Rotate tophandler to align twistlocks with the container locking holes

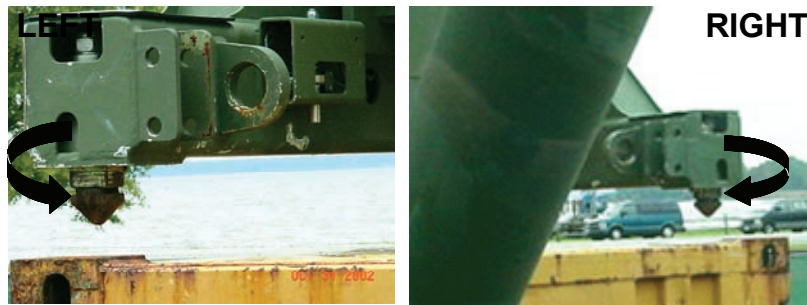

Slide # 116

Side Shift

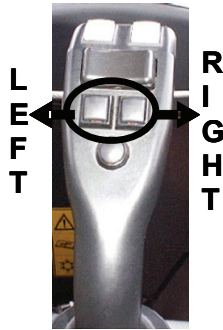

Side shift tophandler left or right to align twistlocks with the container locking holes.

Side shifting should be after rotation side shift gives you a long and short side of the tophandler making rotation alignment harder.

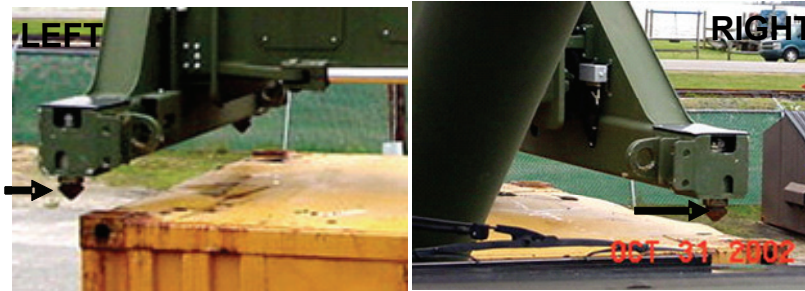

Slide # 117

Lowering Tophandler

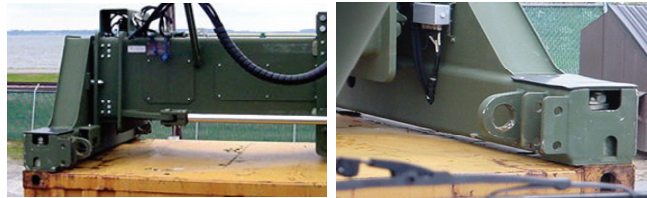

Move joystick forward while pressing multiple function trigger button to lower twistlocks into the container locking holes.



Slide # 118

Yellow Alignment Light

Check that the **YELLOW** alignment indicator light is on.

This indicates that all four twistlocks are engaged in the locking holes of the container.

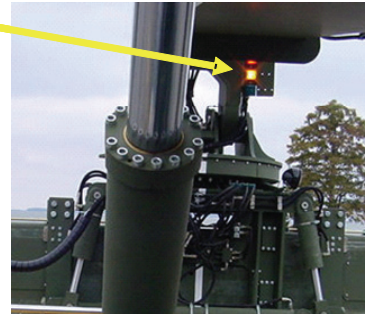

Slide # 119

Green Indicator Light

After yellow light comes on, press and hold twistlocks button until green light comes on. This will lock and secure the load.

When load is lifted, the yellow alignment indicator light will go out.



Oscillation and tilt locks should be disengaged before raising the load (lights out).

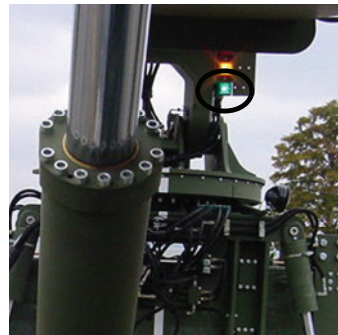
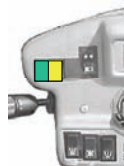

Slide # 120

Lifting the Load

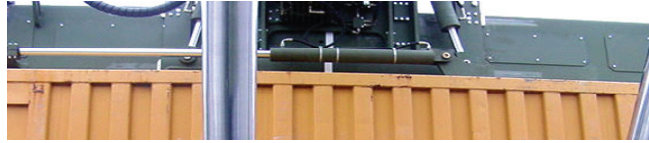

To raise the load move the joystick back while pressing the multiple function trigger button to raise and extend boom.

This will reduce the chances of the container hitting the wheels.

After the bottom of container is clear of the fenders release the multiple function and continue to raise boom until the bottom of the load is above the driver's field of view. On RT-240 V2 it must be raised to 340" and fully retracted or the maximum traveling speed forward will decrease to 7 mph.



Slide # 121

Traveling With Load



Before traveling (MOVING) with a load, CENTER and LEVEL the load.

Position the bottom of the load just above your FIELD OF VIEW, 340" with the BOOM FULLY RETRACTED. Oscillation and tilt locks must be ENGAGED (lights on).

Slide # 122

Stacking Containers Two High

Same as one high except that it is important that all four corners touch at the same time and it must be even and straight with tier one MILVAN.

The multiple function button should be used when releasing and raising tophandler from the MILVAN.

This will allow a smooth release of the tophandler when the tophandler is raised from the MILVAN.



Slide # 123

Stacking Containers Three High

Same as two high. It is VERY IMPORTANT that all four corners touch at the same time and it MUST be even and straight with lower tiers.

The multiple function button MUST be used when raising tophandler from the MILVAN.

This will allow a smooth release of the tophandler when the tophandler is raised from the MILVAN.



Slide # 124

Picking Up Container From Tier 3

- Picking up a container from 3 high is the same as one or two high except that the multiple function button **MUST** be used.
- A ground guide should be used. The operator has limited visibility of the tophandler.
- The boom must be lowered and retracted and MILVAN in travel mode before the RTCH can be moved.



Slide # 125

Row Two Containers

All tiers of row two containers have a weight limit of 27,500

Row one containers should be one tier less in height than row two. This will allow safer and better visibility of row two. A ground guide should be used when working row two containers.



Slide # 126

Picking Up Container Longitudinal



One High Only 20' or 40'



40 foot must be empty

Slide # 127

Picking Up Container Longitudinal

Stop RTCH before approaching MILVAN.

Select crab steering gives the best side to side movement.

- Extend boom to 150" load center.
- Rotate tophandler 90 degrees clockwise to longitudinal position.
- Raise tophandler high enough to clear top of MILVAN and approach slowly.



Slide # 128

Picking Up Container Longitudinal

Center and level tophandler with MILVAN while approaching.



Use crab steering to line the tophandler with MILVAN longitudinal while approaching.

Slide # 129

Picking Up Container Longitudinal

Turn both float locks off (unlocked) when entering the holes on MILVAN.

Engage front twistlocks first



Slide # 130

Picking Up Container Longitudinal

- Rotate tophandler 90 degrees counterclockwise to travel position.
- The MILVAN should be no more than 10 to 12 inches off the ground when rotating.
- The boom cannot be raised high or the tophandler will hit the boom.
- The MILVAN must be in travel mode before the RTCH can be moved.



Slide # 131

Picking Up Container At A Angle

When approaching a row of MILVAN's for pick up, approach at a angle of greater than 45 degrees.



Slide # 132

Picking Up Container At A Angle

Extend boom and position the center of tophandler in the center of the MILVAN.
Position left or right wheel as close as possible to MILVAN.

When extending the boom, the maximum lifting capability cannot be exceeded when the MILVAN is loaded.

If the lifting capability is exceeded, increase the angle.

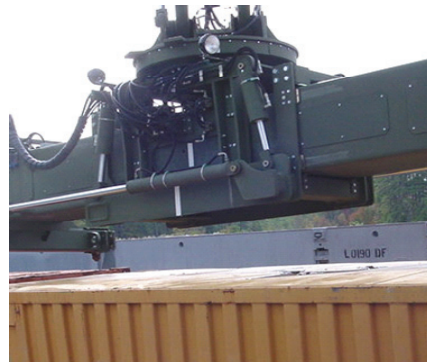

Slide # 133

Slave Starting

Connect slave cable to booster vehicle slave receptacle

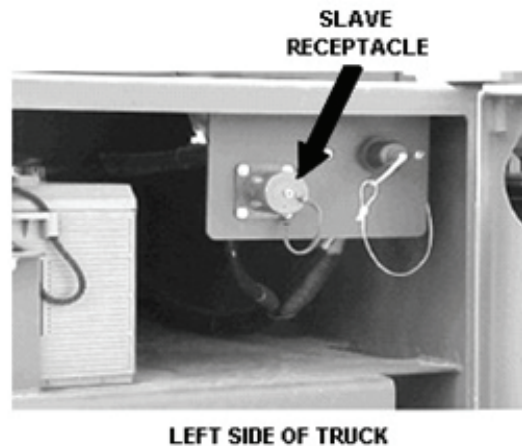

Slide # 134

Lower Boom (Retracted and Unloaded)

- Loosen emergency lowering valve jam nuts on both left and right lift cylinder locking valves.
- Turn both left and right emergency lowering valve screws counterclockwise, three turns.

- Turn left emergency lowering valve screw an additional three counterclockwise turns.
- Turn right emergency lowering valve screw an additional three counterclockwise turns.
- When boom is fully lowered, close both left and right emergency lowering valve screws by turning them clockwise until tight.
- Tighten both left and right jam nuts.

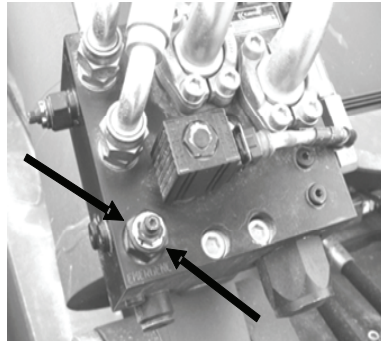

Slide # 135

Lower Boom (Extended or Loaded With a Container)

Open valve located under vehicle, on right frame forward of right-rear tire.

Turn vehicle ignition on.

Press auxiliary pump switch on instrument panel on. It will run for four minutes, then pause for two minutes, then restart, if necessary.

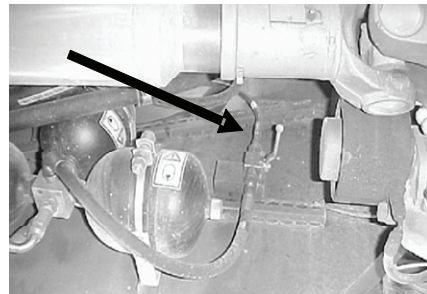

Use joystick to lower and retract the boom.

Slide # 136

Fording

Maximum fording depth is 60 inches



Check water depth in several places, thereby allowing for inconsistency of bottom. Ensure that bottom of stream is hard enough to be forded, without exceeding maximum fording depth. Do not attempt to ford even the narrowest stream that is more than 60 inches in depth.

Slide # 137

Installing Forklift Kit

The forklift kit attaches to the tophandler twistlocks and hydraulic system. The forklift is attached with the kit in a folded configuration.

The procedure requires two personnel: one person in the cab operating the joystick controls; one person installing/removing retaining pins, connecting the hydraulic quick disconnect hoses, and ground guiding the operator.



Slide # 138

Installing Forklift Kit

- Position tophandler directly over and level with forklift kit.
- Lower tophandler onto forklift kit and secure with twistlocks.

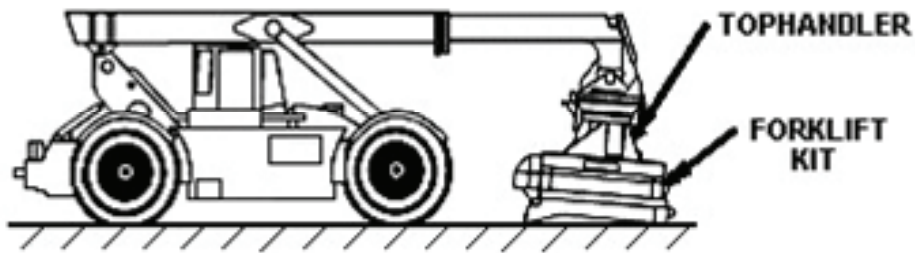

Slide # 139

Installing Forklift Kit

Release locking rings to disconnect two hydraulic hose quick disconnects, located on top left side of the tophandler. Install protective caps on connectors.

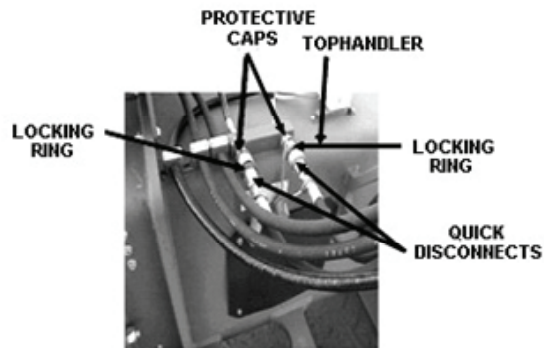

Slide # 140

Installing Forklift Kit

Remove protective caps from forklift kit hydraulic hose connectors. Connect the two forklift kit hydraulic hose quick disconnects to the hydraulic hose quick disconnects that were disconnected from the tophandler.

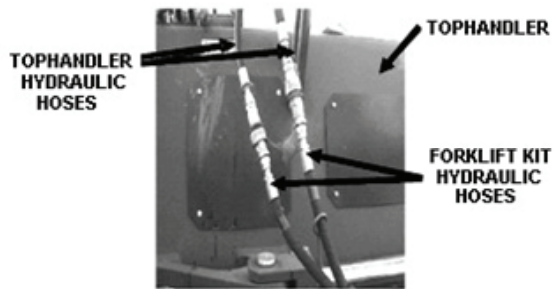

Slide # 141

Installing Forklift Kit

- Remove two locking pins and retaining pins that secure upper fork arms to the top frame.

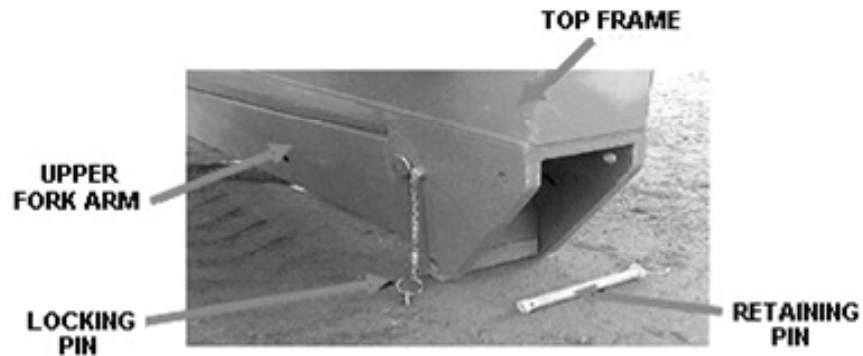

Slide # 142

Installing Forklift Kit

- Stow retaining pins on forklift kit top frame

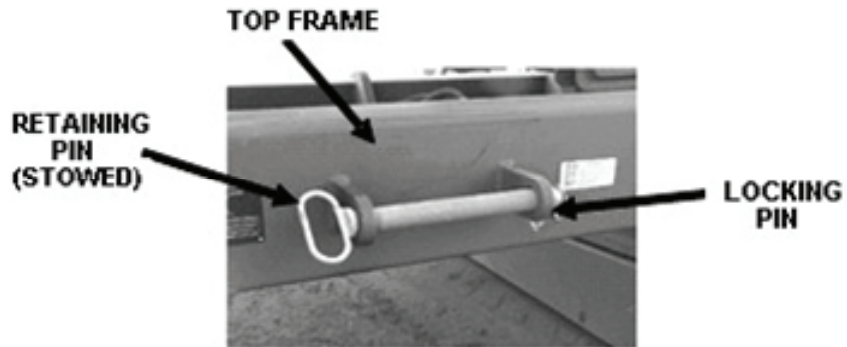

Slide # 143

Installing Forklift Kit

- Slowly tilt the tophandler/forklift kit to the full rearward position while raising the boom. This will allow the upper fork arms to unfold downward.

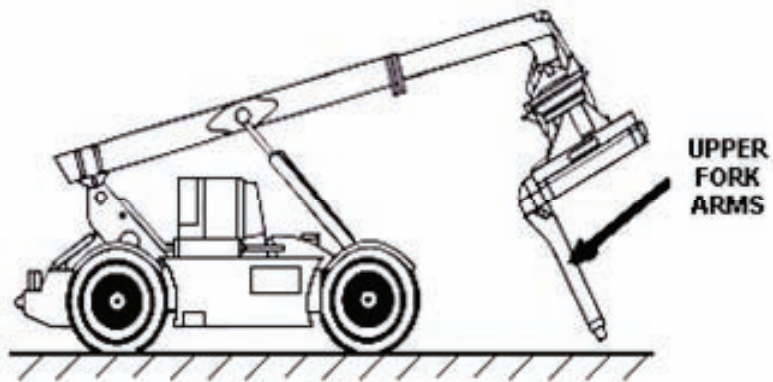

Slide # 144

Installing Forklift Kit

Note

The following step requires a structure such as an MILVAN container or a loading dock to complete the unfolding of the lower forks.

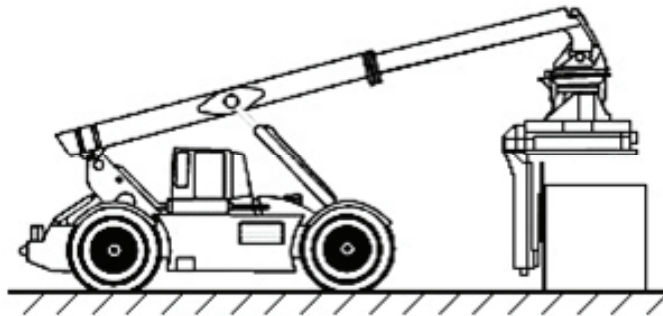

Retract the boom and position the truck in front of an MILVAN container or loading dock.

Slide # 145

Installing Forklift Kit

- Remove two locking pins and retaining pins that secure forks to upper fork arms.

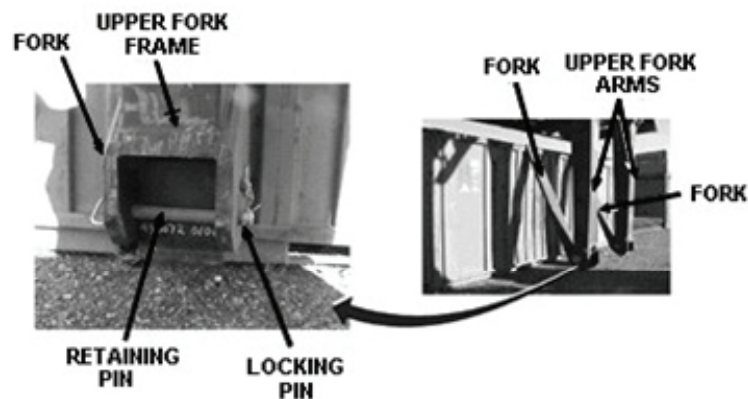

Slide # 146

Installing Forklift Kit

- Raise the boom until the forks are even with sides of the container or vertical wall of the loading dock.
- Extend the boom until the forks are close to the vertical surface.

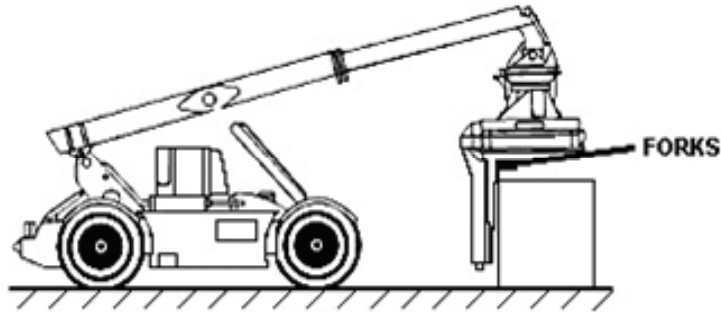

Slide # 147

Installing Forklift Kit

- Place transmission in neutral (N).
- Slowly tilt the tophandler/forklift kit forward, then raise the boom. This will allow the RTCH to move rearward and the forks to fold out to the horizontal position.

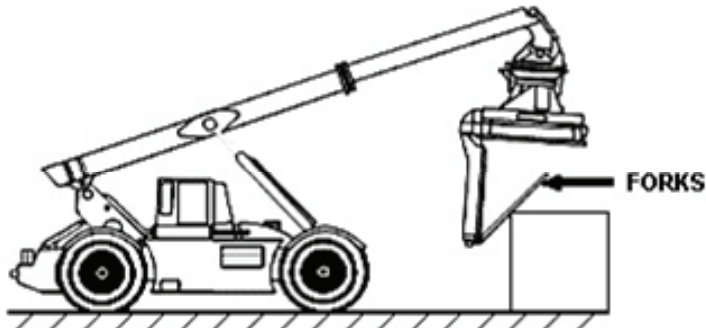

Slide # 148

Installing Forklift Kit

- Retract the boom and level the forklift kit using the joystick tilt control.

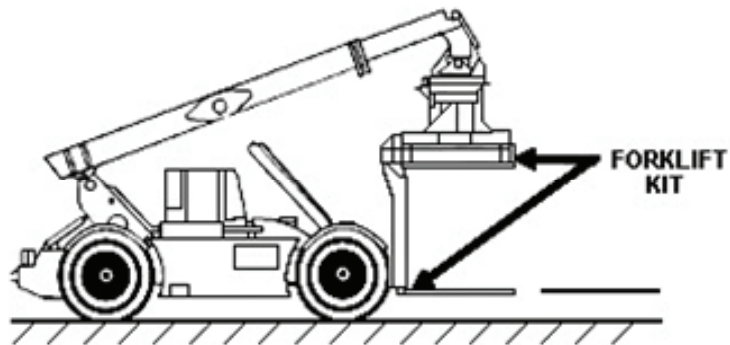

WARNING
UPPER FORK ARMS WILL HIT THE WHEELS

Slide # 149

Installing Forklift Kit

Install retaining pins and locking pins to secure forks to upper fork arms.

NOTE
Retaining pins should be installed from the outside.

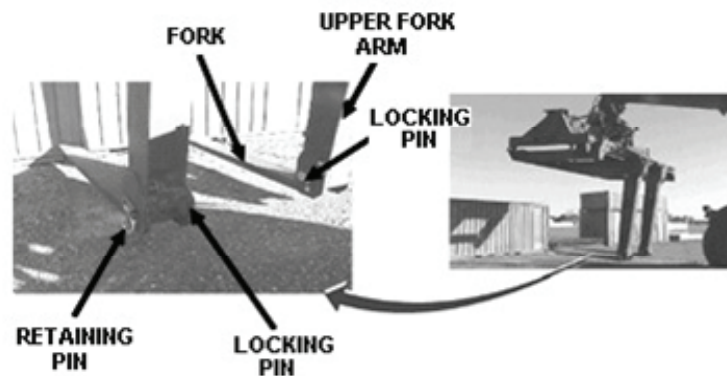

Slide # 150

Self Deployment

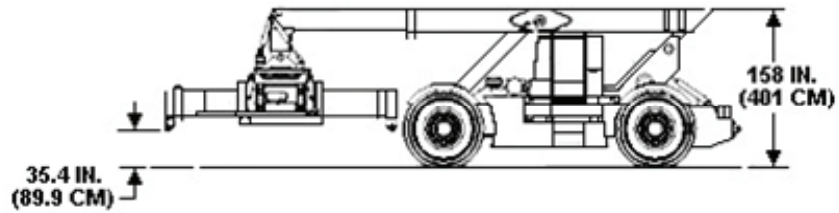

- Boom fully lowered.
- Extended to 150 inches load center.
- Rotate tophandler 90 degrees clockwise to longitudinal position.
- Tophandler side shifted right 6 inches to 8 inches Float Locks On.
- Position boom in horizontal position. Load control display should read 0 degrees and overall lowered height (OALH) should read 160 inches.
- Retract boom until tophandler is in close proximity to front tires.
- Select two-wheel steer mode.
- Turn on lights and flashers, as required.

Slide # 151

Placing Cab in Transport Position

If boom support is to be lowered, remove retaining pin from boom support locking pin extension on each side of boom support.

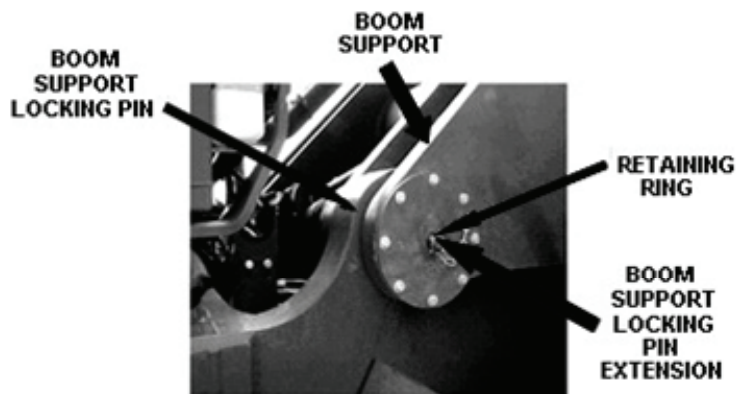

Slide # 152

Placing Cab in Transport Position

Release cab by removing two retaining pins and pins from cab sub-frame.

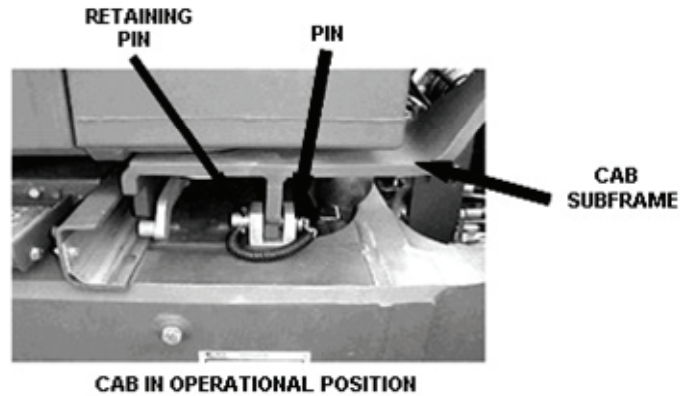

Slide # 153

Placing Cab in Transport Position

- Remove two retaining pins and remove handrail.
- Push auxiliary pump switch on instrument panel inside cab to start auxiliary pump.
- Open door of remote hydraulic control compartment.
- Pull cab lift/lower lever to raise cab transport lift until cab track is level with current cab position.

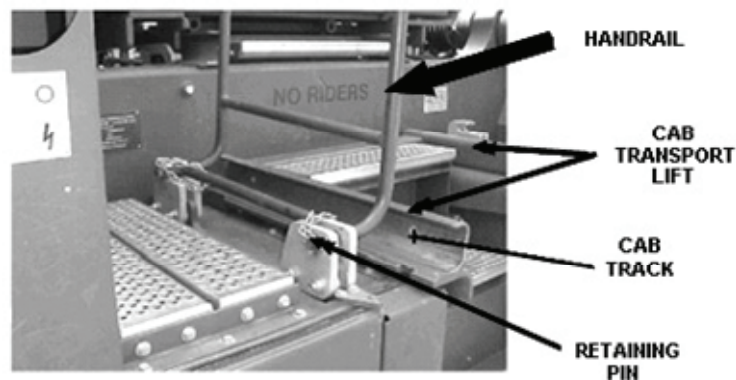

Slide # 154

Placing Cab in Transport Position

Pull cab side movement lever until cab has moved all the way to the left and safety locks drop into place on cab track.

Slowly push cab lift/lower lever and lower cab to transport height.

Push cab side movement lever to move cab slightly to the right, so that cab securing pins can be installed.

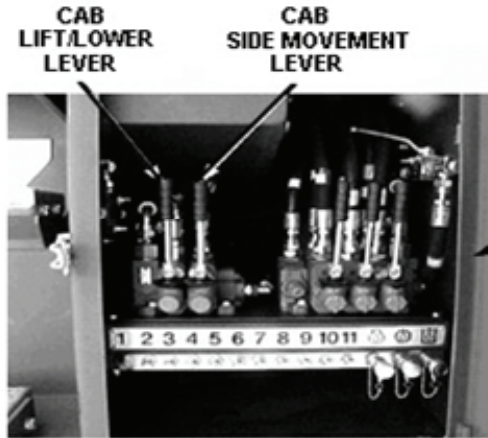

Slide # 155

Placing Cab in Transport Position

NOTE

Pins should be installed from the rear. Install rearmost pin first.

Install two pins and retaining pins to secure cab in transport position.

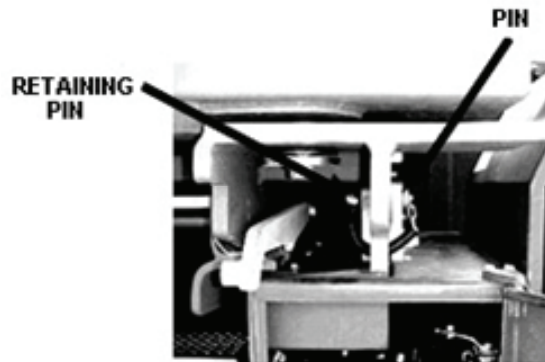

Close and latch door of remote hydraulic control compartment.

Slide # 156

Placing Cab in Transport Position

Reinstall handrail, now configured as a ladder, on cab in transport position. Secure with two retaining pins.

Push auxiliary pump switch on instrument panel inside cab to turn off pump.

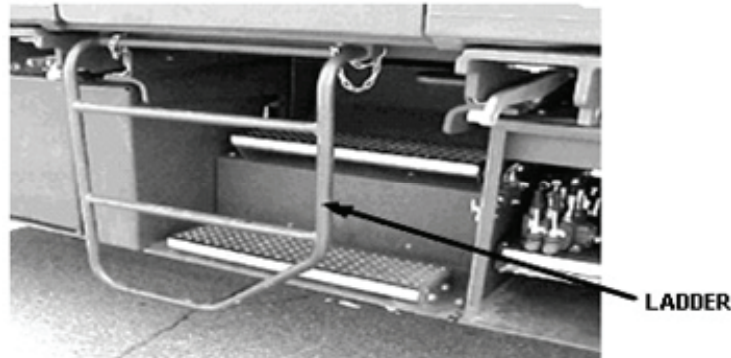

Slide # 157

Fold Boom Support

If not previously removed, remove retaining pin from boom support locking pin extension on each side of boom support.

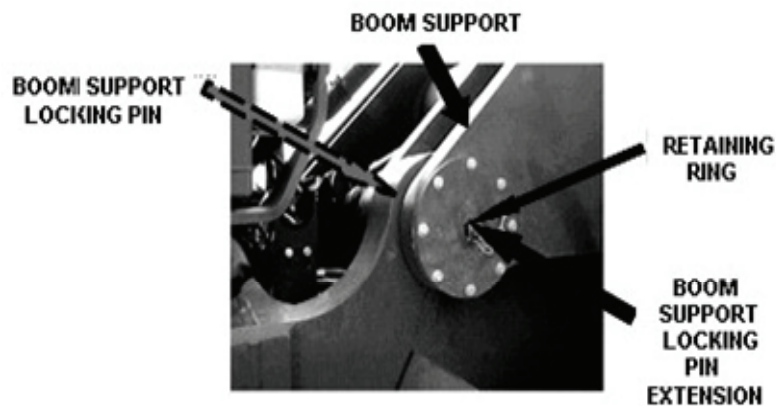

Slide # 158

Folding Boom

- Raise boom folding-cylinders to aid in releasing boom support locking pins.
- Push locking pins lever to retract boom support locking pins.

Use one hand only on levers.

CAUTION

ENSURE LOCKING PINS ARE FULLY RETRACTED TO AVOID DAMAGING THEM.

VISUALLY INSPECT BOTH SIDES TO ENSURE LEFT AND RIGHT BOOM SUPPORT LOCKING PINS HAVE FULLY RETRACTED.

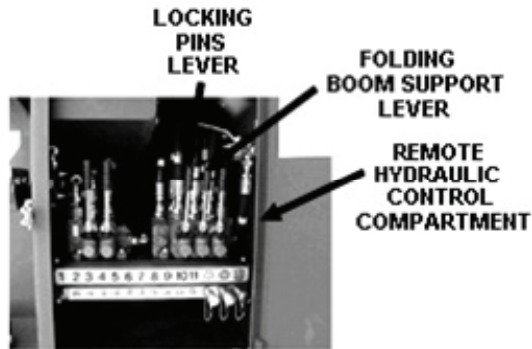

Slide # 159

Folding Boom

- Push folding boom support lever to fold boom support.
- For highway or rail transport, lower boom support until it will not fold any more.

For air transport, lower boom support to 30-degree mark on frame.

Pull locking pins lever to extend boom support locking pins. Install retaining pins to secure in locked position.

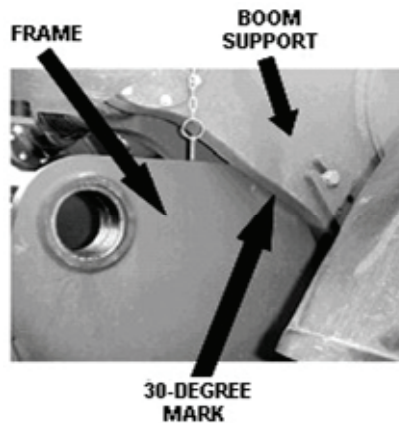

Slide # 160

Folding Boom

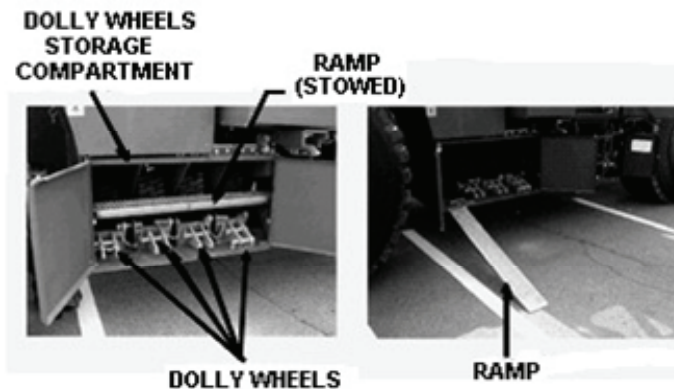

WARNING
ENSURE THAT TABS ON RAMP ARE ENGAGED INTO RAMP SEAT HOLES IN DOLLY WHEELS STORAGE COMPARTMENT. FAILURE TO SECURE RAMP PROPERLY MAY CAUSE RAMP TO FALL UNDER WEIGHT OF DOLLY WHEEL, CAUSING INJURY TO PERSONNEL.

Slide # 161

Folding Boom

- Install each dolly wheel to tophandler.
- Place dolly wheel so that tire will be under the twistlock when tophandler is lifted.
- Install upper pin from outside of tophandler. Lock pin in position with retaining pin.
- Remove lower pin from dolly wheel and set aside.

NOTE
 When installed, front and rear dolly wheels are turned toward each other.

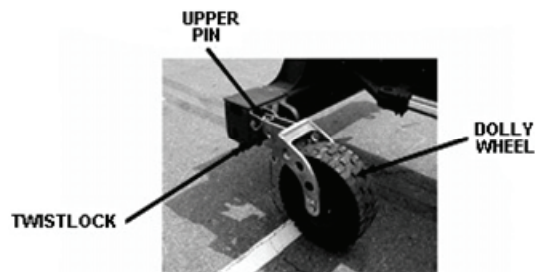

Slide # 162

Folding Boom

- Stow ramp in dolly wheels storage compartment. Secure ramp with straps.
- Raise tophandler so that dolly wheels are off the ground approximately 2 feet.
- Install lower pin in lower hole of each dolly wheel. Lock pin in position with retaining pin.

WARNING
DO NOT USE PIN AS
A HAMMER. DAMAGE
TO PIN WILL RESULT.

Lower tophandler until all four dolly wheels are resting on the ground.

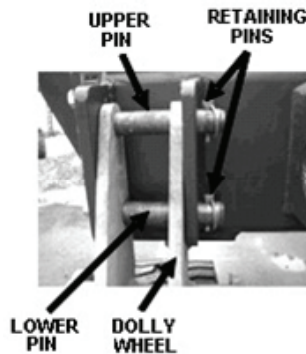

Slide # 163

Folding Boom

- After installing dolly wheels to tophandler: the boom must be allowed to float on the dolly wheels when loading on aircraft.
- On side of each locking valve at base of each lift cylinder, loosen float valve jam nut and turn float valve screw five turns counterclockwise. Retighten jam nut to prevent loss.

Turn valve screw slowly to allow pressure to bleed off slowly if boom is not on stops, boom may drop.

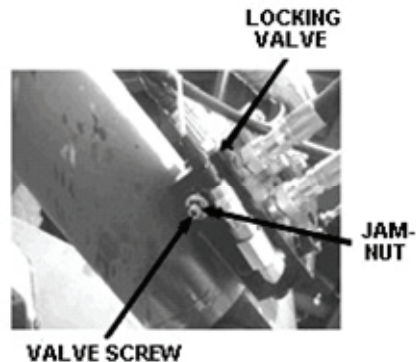

Slide # 164

Folding Boom

At front of vehicle, open both shutoff valves.

SLOWLY AND AT THE SAME TIME

Tophandler should now be resting on dolly wheels, in floating position.

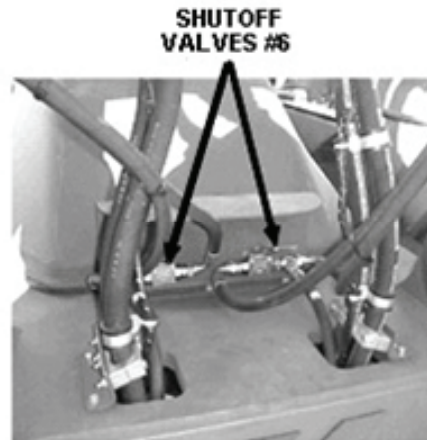

Slide # 165

Bogie Wheels

- Before loading on Aircraft bogie wheels must be lowered down to relieve some of the weight from rear axle.
- Slowly pull bogie wheels lever to raise bogie wheels.

Raise bogie wheels only enough to allow bogie wheels retaining collar to be unlocked.

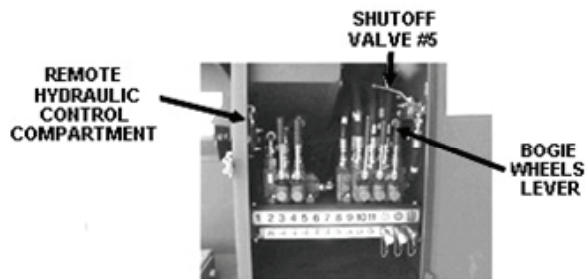

Slide # 166

Bogie Wheels

Turn bogie wheels retaining collar $\frac{1}{4}$ turn clockwise to unlock bogie wheels. If retaining collar is still tight, use handle stowed forward of bogie wheels to rotate shaft.

Push bogie wheels lever to lower bogie wheels; ensure wheels are lowered sufficiently to apply ground pressure.

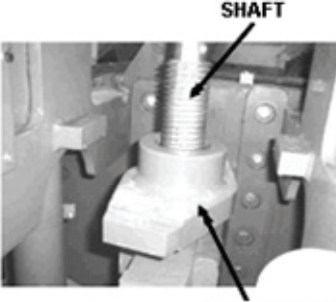

SHAFT

RETAINING COLLAR (UNLOCKED)

Slide # 167

Bogie Wheels

Open shutoff valve #5 inside remote hydraulic control compartment by turning handle 90 degrees counterclockwise.

Bogie wheels will lower further and apply correct amount of ground pressure.

SHUTOFF VALVE #5

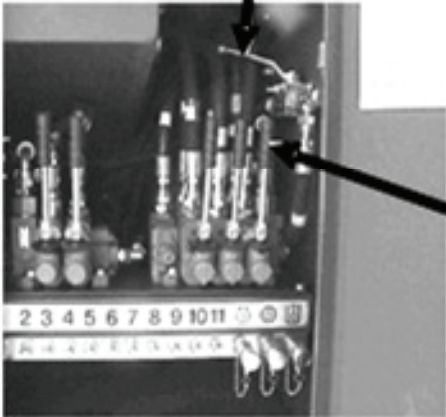

BOGIE WHEELS LEVER

Slide # 168

Loading RTCH on Aircraft

CAUTION
OVER STEERING WILL DAMAGE DOLLY AND BOGIE WHEELS.

After loading is complete.

- Lower boom support to the maximum onto the frame.
- Rotate bogie wheels retaining collar $\frac{1}{4}$ turn clockwise to lock bogie wheels in position. It may be necessary to screw shaft down to take up slack in bogie wheels lock.
- Close shutoff valve # 5 by turning handle 90 degrees clockwise.

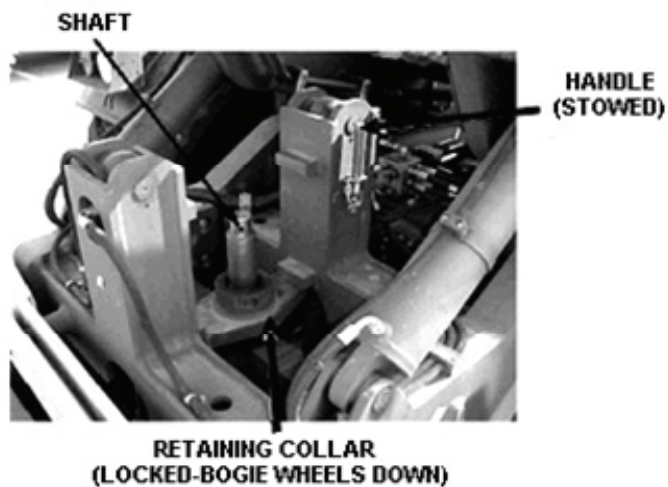

Slide # 169

This page intentionally left blank.

Appendix B

FORCE PROTECTION ANNEX

- Hard hats, ear plugs, safety boots, and work gloves will be worn at all times.
- No horse playing or running in motor pool or training site.
- Always know your work area (such as building, fire hydrants, and so on).
- Never smoke while working around or operating vehicle.
- Never wear loose clothing or jewelry while working on or operating a vehicle.
- Never stand under forks or tophandler except during PMCS.
- No jumping off vehicle.
- Keep vehicle clean of grease, fuel, and oil rags (for example, trash in operator's cab).
- Release radiator cap slowly when checking coolant to keep from getting burned by scalding fluid.
- Install shipping link when working in pivot/articulation area or shipment.
- Release hydraulic pressure before doing any work on hydraulic system. (Take off cap slowly to release pressure.)
- Make sure all safety guards and covers are in place before operating vehicle, unless necessary maintenance purposes.
- The rollover protective structure will not protect you during a rollover if it is damaged.
- Keep all personnel clear of work area.
- Vehicle is not made for assistant operator (such as riding on catwalk).
- Place range selector in neutral and apply parking brake before stopping.
- Always test mast controls before beginning operation.
- Never move vehicle without proper brake oil pressure.

WARNING

**CARBON MONOXIDE (EXHAUST FUMES) CAN KILL YOU.
ALWAYS OPERATE VEHICLE WITH THE WINDOWS OPEN.**

- Always wear your SEAT BELT.

This page intentionally left blank.

Appendix C

60 RULES OF SAFETY FOR OPERATING MATERIAL HANDLING EQUIPMENT

It is impossible to compile a complete list of all safety precautions covering all situations. However, there are basic safety precautions that must be followed during your daily routine. Safety is your PRIME RESPONSIBILITY, since any piece of EQUIPMENT IS ONLY AS SAFE AS THE PERSON AT THE CONTROLS

1. No running/horse playing in the motor pool/training site.
2. No walking on or between the Material Handling Equipment (MHE) except during PMCS.
3. Hearing protection, safety shoes, and safety hat will be worn in the motor pool/training site.
4. Never operate MHE with engine panels open.
5. Never stand behind MHE while engine is running.
6. Never stand directly in front of MHE while engine is running.
7. Only one student in MHE at any time.
8. Before moving MHE sound horn to warn nearby personnel that you are moving. When going in reverse sound horn twice. Once for forward.
9. Turn on lights before operating MHE and turn off before shutting down MHE.
10. Break in authorized areas, designated by instructors.
11. Movement will be in formation or range walk only.
12. No walking across training site; walk on outer edges only.
13. No standing or walking between pallets/cargo trucks and the MHE.
14. Only one signal person at a time. If operator cannot see signal person operator will stop.
15. When operating MHE, the safe following distance is at least two (2) MHE lengths apart.
16. Give hand/arm signals distinctly to prevent misunderstanding which could result in an accident; remove gloves before giving hand and arm signals.
17. Do not use MHE to lift personnel.
18. Do not stand on MHE while traveling, or allow riders.
19. Do not drive MHE toward a person standing in front of a fixed object.
20. Never use control levers as a handhold when mounting/dismounting MHE.
21. Use "Three Points of Contact" and clean shoes before mounting/dismounting MHE.

22. Never use drugs or alcohol prior to/or during operation of MHE.
23. Never enter MHE while it is moving.
24. Do not wear loose fitting clothing, ring, or jewelry while operating MHE.
25. Keep all parts of your body inside the operator's compartment.
26. Never lift load over any person.
27. Do not allow others to pass under boom, forks tophandler, or load.
28. If you cannot see stop operation and, have someone direct you.
29. Know the positions and functions of all controls before attempting to operate MHE.
30. Understand the speed, breaking, steering, and stability characteristics of MHE before operating it.
31. With or without rated capacity load, for maximum longitudinal stability, do not exceed 45 percent (24°) up or downgrade.
32. With or without rated capacity load, for maximum lateral stability, do not exceed 30 percent grades (17°).
33. Loaded Forklift: With forks (and load) pointing uphill.
34. Empty Forklift: With forks pointing downhill.
35. Do not down shift at high speeds.
36. Know your vehicle's operating limits for ascending and traversing slopes.
37. Refer to load rating chart before attempting to lift load.
38. Never exceed load LIMITS.
39. Never exceed load RANGE.
40. Place the load safely. Be sure the landing point you intend to use can safely support the load.
41. If there is any indication of instability during the lift, (movement, leaning, swaying,) lower the load. Move vehicle to a more stable position.
42. Never transport a load with boom extended. Vehicle may tip over.
43. Always keep load level and centered at all times. Vehicle may tip over.
44. When traveling over ramps, bridges, and so forth, ensure that they can support the combined weight of vehicle and load.
45. Always retract boom before lowering it. Vehicle instability may result.
46. At no time will ground guides run or walk backwards while guiding a vehicle.

47. When backing keep looking back until you have stopped. If you shift your eyes to the front as soon as you are ready to stop, you will be BACKING BLINDLY FOR SEVERAL FEET.
48. Always come to a full stop before shifting into forward or reverse gear.
49. Never back long distances unless absolutely necessary. It is much safer to turn around and cover the distance going forward.
50. Ground guides should keep 10 yards between themselves and the vehicle front or rear corners.
51. Three Point Guide: When backing because of the visibility restrictions this is the only safe method that can be used with MHE.
52. Know all warning symbols for the MHE, cargo, and the TMs work and be safe follow their warning.
53. Never leave the operator's position without applying the parking brake.
54. Only One Ground Guide Gives Signals to the operator.
55. Be sure that everyone involved (the operator and ground guides) understand who will give the signal and who will receive it before any movement is done.
56. During movement within an assembly area, wheeled vehicles require ground guides when moving forward and when backing.
57. Ground guides are also required when vehicles enter a field site operations area.
58. Never use mirror to back use your ground guide.
59. No smoking in or around MHE.
60. No eating or drinking in cab of MHE.

Students—

- You, the operator, are the only one who can be relied upon to assure the safety of yourself and those around you.
- Be a PROFESSIONAL and follow the RULES of safety.
- REMEMBER, failure to follow just one safety precaution can cause that accident to people or equipment.
- You are responsible for the safety of yourself and those around you.
- Because you, the operator, are the only part of the MHE that can think and reason, your responsibility is not lessened by the addition of operational aids or warning devices. Indeed, you must guard against acquiring a false sense of security when using them.
- They are there to ASSIST, NOT direct the operation. Operational aids or warning devices can be mechanical, electrical electronic or a combination thereof.
- They are subject to failure or misuse.

KNOW AND ABIDE BY THE SAFETY RULES THINK AND
REASON BEFORE DOING ANYTHING

SPEED AND SHORT CUTS ONLY KILL SOONER OR LATER

Appendix D

PRACTICAL EXERCISES**WORKSHEET NUMBER SHEET 1 - PE 1****INTRODUCTION TO THE KALMAR RTCH AND FAMILIARIZATION****INTRODUCTION**

MOTIVATOR: Using personal experience or related story, explain why this lesson is important to the student.

TERMINAL LEARNING OBJECTIVE:

To become familiar with the location and purpose of the major Kalmar RT-240 RTCH components, controls, and instruments.

Note. The instructor should inform the students of the following terminal learning objective (TLO) covered with this practical exercise (PE). At the completion of this lesson, you (the student) will:

Action: The student will implement the responsibilities of the operator's controls, and instruments. Operational maintenance, safety, and basic knowledge and skills to operate the Kalmar 53,000-pound RT-240 RTCH.

Conditions: Given TM 10-3930-675-10-1, TM 10-3930-675-10-2, and a Kalmar 53,000-pound RT-240 RTCH. The student will coordinate the characteristics, major components and capabilities of the Kalmar RT-240 RTCH for operation.

Standard: To receive a "GO" for this lesson, the student will be able to accomplish the starting/operating/stopping engine procedures of the Kalmar 53,000-pound RT-240 RTCH. Use the RTCH to demonstrate start up and shutting down Engine, apply parking brake, retracting and fully lowering the Boom, Place transmission control lever in neutral, and place master switch to OFF. Student must correctly answer all check on learning questions.

SAFETY REQUIREMENTS:

- Instructor will use the safety annex 60 Rules of Safety for Operating Material Handling Equipment (MHE) to conduct Safety Briefing before operations begin each morning and maintain direct supervision though out the day.
- Safety will be discussed and practiced throughout this lesson.
- Safety clothing (hard hats, gloves, and steel toed boots, hearing protection) will be worn at all times while performing these tasks.
- One Instructor will be with MHE at all times with one student without TA 50. Student will sound warning before movement. Back only with ground guides using 3-point system. Look before backing and keep looking back until stopped. Never back long distances and never use mirrors for backing.

RISK ASSESSMENT LEVEL: Moderate.

ENVIRONMENTAL CONSIDERATIONS: It is the responsibility of all Soldiers and DA civilians to protect the environment from damage. AR 200-1 delineates TRADOC responsibilities to integrate environmental requirements across DOTMLPF and ensure all training procedures, training materials, and training doctrine, to include sound environmental practices and considerations. The Army's environmental standard is to be a national leader in environmental and natural resource stewardship for present and future generations. This training support package meets this standard.

EVALUATION: Inform the Soldiers how, when, and where performance of the TLO will be evaluated. This lesson is examinable under Performance PE.

INSTRUCTIONAL LEAD IN: Transition students to presentation using personal experience or related story explain why this lesson is important to the students.

RESOURCE REQUIREMENTS: R16611, Rough Terrain Container Handler or RTCH Simulator (Quantity (Qty) is based on the equipment to student Ratio 1:2).

SPECIAL INSTRUCTIONS: Instructor will have students perform preventive maintenance checks and services on each Kalmar RT-240 RTCH before operations begin each morning.

PROCEDURES: Perform PE: Demonstrate the location and description of major components on the Kalmar RT-240 RTCH.

1. Learning Step/Activity 1. Location and Description of Major Components.

Method of instruction: PE

Instructor to student ratio is: 1:2

Time of instruction: .5 hours

Media: TD

Instructor will use TM 10-3930-675-10-1 and TM 10-3930-675-10-2 WP 0002 00-3 thru 7 and take students on a walk around of the out side of Kalmar RT-240 RTCH pointing out the location and descriptions of major components.

PROCEDURES: Perform PE: Demonstrate the use of instrument panel.

2. Learning Step/Activity 2. Instrument Panel.

Method of instruction: PE

Instructor to student ratio is: 1:2

Time of instruction: .3 hours

Media: TD

Instructor will use TM 10-3930-675-10-1, TM 10-3930-675-10-2, WP 0004 00-1 thru 6 point out the descriptions, operation, and use of the Kalmar RT-240 RTCH instrument panel

PROCEDURES: Perform PE: Demonstrate the use and location of steering column, accelerator, and brake controls.

3. Learning Step/Activity 3. Steering Column, Accelerator, and Brake Controls.

Method of instruction: PE

Instructor to student ratio is: 1:2

Time of instruction: .3 hours

Media: TD or SI

Instructor will use TM 10-3930-675-10-1, TM 10-3930-675-10-2, WP 0004 00-7 and WP 0004 00-9 point out the description, operation, and use of the Kalmar RT-240 RTCH Steering wheel and Steering Column, Accelerator, and Brake controls

PROCEDURES: Perform PE: Demonstrate the location and use of boom and tophandler joystick controls.

4. Learning Step/Activity 4. Boom and Tophandler Joystick Controls.

Method of instruction: PE

Instructor to student ratio is: 1:2

Time of instruction: .4 hours

Media: TD or SI

Instructor will use TM 10-3930-675-10-1, TM 10-3930-675-10-2, WP 0004 00-10 and WP 0004 00-11 and demonstrate the operation and use of the Kalmar RT-240 RTCH boom and tophandler joystick controls, rotating, side shifting, lifting, lowering, oscillation, and tilt angles, twistlocks and twistlocks indicator lights.

SPECIAL INSTRUCTIONS: Instructor should start and drive the RTCH, demonstrating the operation and handling of the Kalmar RT-240 RTCH with one student and instructor in cab.

PROCEDURES: Perform PE: Demonstrate the engine starting procedures.

5. Learning Step/Activity 5. Kalmar RT-240 RTCH Engine Starting Procedures.

Method of instruction: PE

Instructor to student ratio is: 1:2

Time of instruction: .3 hours

Media: TD

Instructor will use TM 10-3930-675-10-1, TM 10-3930-675-10-2, WP 0005 00-2, and demonstrate engine starting procedures of the Kalmar RT-240 RTCH cold and hot starts.

PROCEDURES: Perform PE: Demonstrate the operation of the parking brake, transmission control lever, and steering modes.

6. Learning Step/Activity 6. Parking Brake, Transmission Control Lever, and Steering Modes.

Method of instruction: PE
Instructor to student ratio is: 1:2
Time of instruction: .2 hours
Media: TD

Instructor will use TM 10-3930-675-10-1, TM 10-3930-675-10-2, WP 0005 00-4, WP 0005 00-3, and WP 0005 00-5 thru WP 0005 00-6 and demonstrate the operation and use of the Kalmar RT-240 RTCH parking brake, transmission control lever, and steering modes.

PROCEDURES: Perform PE: Demonstrate operation under usual conditions.

7. Learning Step/Activity 7. Operation Under Usual Conditions.

Method of instruction: PE
Instructor to student ratio is: 1:2
Time of instruction: .6 hours
Media: TD

Instructor will use TM 10-3930-675-10-1, TM 10-3930-675-10-2, WP 0005 00-7 thru –20 and demonstrate driving the Kalmar RT-240 RTCH under usual conditions, warnings on driving tips, use of fuel gauge, indicators, and electronic control system display screen, avoid over steering and hard braking, field of view, position of tophandler and boom during operation, operate boom and control of tophandler with joystick operation and container load range.

SPECIAL INSTRUCTIONS: After demonstrating operation of Kalmar RT-240 RTCH, instructor should allow student to drive and operate the joystick without load with instructor guidance in cab.

PROCEDURES: Perform PE: Operation under usual conditions.

8. Learning Step/Activity 8. Operation Under Usual Conditions.

Method of instruction: PE 1
Instructor to student ratio is: 1:1
Time of instruction: 4.0 hours
Media: TD or SI

Instructor will use TM 10-3930-675-10-1, TM 10-3930-675-10-2, WP 0005 00-7 thru –20 to allow students to drive the Kalmar RT-240 RTCH with out load under usual conditions, indicators, and electronic control system display screen, avoid over steering and hard braking, operate boom and control of tophandler with joystick operation, boom load range, field of view, and position of tophandler and boom during operation.

PROCEDURES: Perform PE: Demonstrate shutting down engine.

9. Learning Step/Activity 9. Shutting Down Engine.

Method of instruction: PE 1
Instructor to student ratio is: 1:2
Time of instruction: .2 hours
Media: TD

Instructor will use TM 10-3930-675-10-1, TM 10-3930-675-10-2 (WP 0005 00-22) and demonstrate shutting down engine, apply parking brake, retract and fully lower boom, place transmission control lever in neutral, allow engine to run for 1/2 to 1 minute at idle, place master switch to OFF. Student should perform after-operations PMCS using WP 0013 00-7 thru 13.

Note. Caution students to never turn master switch battery switch to OFF when the engine is running. Damage to voltage regulator may result.

PROCEDURES: Perform demonstration by critiquing students on demonstration and PE.

10. Learning Step/Activity 10. Critique Students.

Method of instruction: PE
Instructor to student ratio is: 1:2
Time of instruction: .2 hours
Media: TD

Instructor will use Kalmar RT-240 RTCH and critique the Demonstration and PE 1.

Note. Conduct a check on learning and summarize the learning activity.

FEEDBACK REQUIREMENTS: Schedule and provide feedback on the PE and any information to help answer student's questions. Provide remedial training as needed.

**SOLUTION FOR PRACTICAL EXERCISE
PE/Kalmar RT-240 RTCH Familiarization - PE 1**

Instructor will ensure that the student is familiar with the Kalmar RT-240 RTCH major components, instrument panel, starting and stopping the engine, driving, and joystick operation without load (see TM 10-3930-675-10-1 and TM 10-3930-675-10-2).

Student Handouts

- TM 10-3930-675-10-1.
- TM 10-3930-675-10-2.
- Engine Starting and Driving (Handout #1).
- Operator's Controls and Indicators Electronic Control System (ECS) Display Screens (Handout #2).
- Joystick Operation (Handout #3).
- Major Components Left Side (Worksheet #1).
- Major Components Right Side (Worksheet #2).
- Instrument Panel (Worksheet #3 and Worksheet #4).
- Operator's Controls and Indicators ECS Menu Selection Buttons (Worksheet #5).
- Operator's Controls and Indicators ECS Menu Selection Buttons (Worksheet #6).
- Boom and Tophandler Controls (Worksheet #7).
- Remote Hydraulic Controls (Worksheet #8).
- 60 Rules of Safety for Operating Material Handling Equipment (MHE) (Appendix C).

**PRACTICAL EXERCISE AND SOLUTIONS
WORKSHEET NUMBER SHEET 2 – PE 1**

Preventive Maintenance Checks and Service (PMCS)

MOTIVATOR: Using personal experience or related story, explain why this lesson is important to the student.

TERMINAL LEARNING OBJECTIVE:

Note. The instructor should inform the students of the following terminal learning objective (TLO) covered with this PE.

At the completion of this lesson, you (the student) will:

Action: Be able to complete PMCS on the Kalmar 53,000-pound RT-240 Rough Terrain Container Handler (RTCH).

Condition: Given TM 10-3930-675-10-1, TM 10-3930-675-10-2, and Kalmar 53,000-pound RT-240 Rough Terrain Container Handler (RTCH) will perform PMCS inspection on the Kalmar RT-240 RTCH.

Standards: To receive a “GO” for this lesson, the student will complete the PMCS of the Kalmar 53,000-pound RT-240 RTCH and correctly answer all check on learning questions.

SAFETY REQUIREMENTS:

- Instructor will use the safety annex 60 Rules of Safety for Operating Material Handling Equipment (MHE) and conduct Safety Briefing before operations begin each morning and maintain direct supervision though out the day.
- Safety will be discussed and practiced throughout this lesson.
- Safety clothing (hard hats, gloves, and steel toed boots, hearing protection) will be worn at all times while performing these tasks.
- One Instructor will be with MHE at all times with one student without TA 50. Student will sound warning before movement. Back only with ground guides using 3-point system. Look before backing and keep looking back until stopped. Never back long distances and never use mirrors for backing.

RISK ASSESSMENT LEVEL: Moderate.

ENVIRONMENTAL CONSIDERATIONS: It is the responsibility of all Soldiers and DA civilians to protect the environment from damage. AR 200-1 delineates TRADOC responsibilities to integrate environmental requirements across DOTMLPF and ensure all training procedures, training materials, and training doctrine, to include sound environmental practices and considerations. The Army’s environmental standard is to be a national leader in environmental and natural resource stewardship for present and future generations. This training support package meets this standard.

EVALUATION: Inform the Soldiers how, when, and where performance of the TLO will be evaluated. This lesson is examinable under performance PE.

INSTRUCTIONAL LEAD IN: Transition students to presentation using personal experience or related story explain why this lesson is important to the students.

RESOURCE REQUIREMENTS: Rough Terrain Container Handler (based on equipment to student ratio of 1:2).

SPECIAL INSTRUCTIONS: Instructor will perform preventive maintenance checks and services on each Kalmar RT-240 RTCH before operations begin.

PROCEDURES: Perform PE: Demonstrate and perform PMCS on each Kalmar RT-240 RTCH.

1. Learning Step/Activity 1. Preventive Maintenance Checks and Services.

Method of instruction: PE 1
Instructor to student ratio is: 1:2
Time of instruction: .4 hours
Media: TD

Instructor will use TM 10-3930-675-10-1, TM 10-3930-675-10-2, WP 00013 00-1 thru 18 and take students on a walk around of the Kalmar RT-240 RTCH pointing out the location and descriptions of Operator/crew (C) and Organizational Maintenance (O). PMCS on each Kalmar RT-240 RTCH.

Note. Conduct a check on learning and summarize the learning activity.

PROCEDURES: Perform PE: Instructor will have student perform a PMCS on each Kalmar RT-240 RTCH that will be operated for that day.

2. Learning Step/Activity 2. Preventive Maintenance Checks and Services on each Kalmar RT-240 RTCH.

Method of instruction: PE
Instructor to student ratio is: 1:2
Time of instruction: 2.5 hours
Media: TD

Students will use LO 10-3930-675-12, TM 10-3930-675-10-1, TM 10-3930-675-10-2, WP 00013 00-1 thru 18 to complete a Crew/Operator Preventive Maintenance Checks and Services on each Kalmar RT-240 RTCH. Record all deficiencies and shortcomings on DA Form 2404 (Equipment Inspection and Maintenance Worksheet).

Note. Conduct a check on learning and summarize the learning activity.

PROCEDURES: Perform PE: Instructor will have student perform a lubrication order on each Kalmar RT-240 RTCH that will be operated for that day.

3. Learning Step/Activity 3. Lubrication Order.

Method of instruction: PE
Instructor to student ratio is: 1:2
Time of instruction: 2.1 hours
Media: TD

Students will use LO 10-3930-675-12 to compete a Crew/Operator Lubrication on each Kalmar RT-240 RTCH. Record all deficiencies and shortcomings on DA Form 2404.

CAUTION

Students should NEVER turn master switch battery switch to OFF when the engine is running. Damage to voltage regulator may result.

Note. Conduct a check on learning and summarize the learning activity.

PROCEDURES: Perform PE: Demonstrate the reading and use of electronic control system screen on each Kalmar RT-240 RTCH.

4. Learning Step/Activity 4. Electronic Control System Screen.

Method of instruction: PE 1
Instructor to student ratio is: 1:2
Time of instruction: .8 hours
Media: TD

Instructor will use TM 10-3930-675-10-1, TM 10-3930-675-10-2, WP 00020 00-1 thru 45: Demonstrate the reading and use of Electronic Control System screen on the Kalmar RT-240 RTCH pointing out the description and proposes of each screen.

Note. Conduct a check on learning and summarize the learning activity.

PROCEDURES: Perform PE by critiquing students on PE.

5. Learning Step/Activity 5. Critique Practical Exercise.

Method of instruction: PE
Instructor to student ratio is: 1:2
Time of instruction: .2 hours
Media: TD

Instructor will use Kalmar RT-240 RTCH, LO 10-3930-675-12, TM 10-3930-675-10-1, and TM 10-3930-675-10-2 and critique the PE.

Note. Conduct a check on learning and summarize the learning activity.

Note. Perform PE by critiquing students on PE.

FEEDBACK REQUIREMENTS: Schedule and provide feedback on the PE and any information to help answer student's questions. Provide remedial training as needed.

**SOLUTION FOR PRACTICAL EXERCISE
PE 1/KALMAR RT-240 RTCH**

- Weekly preventive maintenance checks and services (PMCS) PE 1.
- Crew/operator lubrication of the Kalmar RT-240 RTCH.
- Reading and using electronic control system screen.

Instructor will ensure that the student is familiar with the PMCS, crew/operator lubrication, and reading the electronic control system screen on the Kalmar RT-240 RTCH (see TM 10-3930-675-10-1, TM 10-3930-675-10-2, WP 00013 00-1 thru -18, WP 00020 00-1 thru -45, and LO 10-3930-675-12).

Student Handouts

- TM 10-3930-675-10-1 and TM 10-3930-675-10-2.
- LO 10-3930-675-12.
- DA Form 2404.
- 60 Rules of Safety for Operating Material Handling Equipment (MHE) (Appendix C).

**PRACTICAL EXERCISE AND SOLUTIONS
WORKSHEET NUMBER SHEET 3 – PE 1**

KALMAR RT-240 V2 UPDATE

MOTIVATOR: Using personal experience or related story, explain why this lesson is important to the student

TERMINAL LEARNING OBJECTIVE: The instructor should inform the students of the following terminal learning objective (TLO) covered with this PE.

Action: Operate the simulator with version 2 type Kalmar RT-240 V2 boom and tophandler movement modifications.

Condition: Given a Kalmar RT-240 V2 RTCH or simulator, TM 10-3930-675-10-1, and TM 10-3930-675-10-2.

Standards: To receive a "GO" for this lesson, the student will Operate and correctly identify the version 2 modifications of the Kalmar RT-240 V2 RTCH, boom and tophandler movement modifications and electronic control system added or changed functions.

SAFETY REQUIREMENTS:

- Instructor will use the safety annex 60 Rules of Safety for Operating Material Handling Equipment (MHE) and conduct Safety Briefing before operations begin each morning and maintain direct supervision throughout the day.
- Safety will be discussed and practiced throughout this lesson.
- Safety clothing (hard hats, gloves, and steel toed boots, hearing protection) will be worn at all times while performing these tasks.
- One Instructor will be with MHE at all times with one student without TA 50. Student will sound warning before movement. Back only with ground guides using 3-point system. Look before backing and keep looking back until stopped. Never back long distances and never use mirrors for backing.

RISK ASSESSMENT LEVEL: Low.

ENVIRONMENTAL CONSIDERATIONS: It is the responsibility of all Soldiers and DA civilians to protect the environment from damage. AR 200-1 delineates TRADOC responsibilities to integrate environmental requirements across DOTMLPF and ensure all training procedures, training materials, and training doctrine, to include sound environmental practices and considerations. The Army's environmental standard is to be a national leader in environmental and natural resource stewardship for present and future generations. This training support package meets this standard.

EVALUATION: Inform the Soldiers how, when, and where performance of the TLO will be evaluated. This lesson is examinable under performance test.

INSTRUCTIONAL LEAD IN: Transition students to presentation using personal experience or related story explain why this lesson is important to the students.

RESOURCE REQUIREMENTS: Kalmar RT-240 RTCH or RT-240 V2 RTCH Simulator (based on the equipment to student ratio of 1:2).

SPECIAL INSTRUCTIONS: Perform practical exercise: Kalmar RT-240 V2 operation under usual conditions with container loaded on tophandler. Off loading/stacking containers two and three high, boom reach, and load range in row one and two.

PROCEDURES: Perform PE: Demonstrate operation of Kalmar RT-240 V2 under usual conditions.

1. Learning Step/Activity 1. Operate Kalmar RT-240 V2 Under Usual Conditions.

Method of instruction: PE
Instructor to student ratio is: 1:2
Time of instruction: 0.8 hours
Media: SI

Instructor will use Kalmar RT-240 V2 Simulators, TM 10-3930-675-10-1, and TM 10-3930-675-10-2 to demonstrate with students the necessary Joystick movements to pick-up one high container. Checking indicators, and electronic control system display screen. Traveling with a load the position of tophandler, and boom during movement operation. Without a container 240 inches high, with a container 340 inches high and the boom fully retracted or the maximum traveling speed forward will decrease to 7 mph. Drag Restriction Lockout Kalmar RT-240 V2. The transmission will lockout in neutral if the load is not lifted off the ground. Tophandler rotation lockout at 15° and 13°.

Note. Conduct a check on learning and summarize the learning activity.

PROCEDURES: Perform PE: Operation under usual conditions.

2. Learning Step/Activity 2. Operate Kalmar RT-240 V2 Simulators Under Usual Conditions Loading/Stacking Containers One High.

Method of instruction: PE
Instructor to student ratio is: 1:2
Time of instruction: 1.0 hours
Media: SI

Instructor will have student use Kalmar RT-240 V2 Simulators, TM 10-3930-675-10-1, and TM 10-3930-675-10-2 to allow students to pick-up one high containers. Checking indicators, and electronic control system display screen. Operate Boom and Tophandler with necessary Joystick movements to pick-up one high container. Traveling with a load the position of tophandler, and boom during movement operation. Without a container 240 inches high, with a container 340 inches high and the boom fully retracted or the maximum traveling speed forward will decrease to 7 mph. Drag Restriction Lockout Kalmar RT-240 V2. The transmission will lockout in neutral if the load is not lifted off the ground. Tophandler rotation lockout at 15° and 13°.

Note. Conduct a check on learning and summarize the learning activity.

PROCEDURES: Perform PE: Under usual conditions with container loaded on tophandler. Off loading/stacking containers two and three high.

3. Learning Step/Activity 3. Using Kalmar RT-240 V2 Simulators Load/Stack Containers Two or Three High.

Method of instruction: PE

Instructor to student ratio is: 1:2

Time of instruction: 1.8 hours

Media: SI

Instructor will use Kalmar RT-240 V2 Simulators, TM 10-3930-675-10-1, and TM 10-3930-675-10-2 to allow students to drive the Kalmar RT-240 V2 RTCH with container loaded on tophandler. Under Usual Conditions, the student will load/off load, stack containers two and three high, and place containers within load range reach in row one and two following all indicators, electronic control system display screen and Kalmar RT-240 V2 limitations. Operate Boom and Control of Tophandler with Joystick operation. Field of view, position of Tophandler and boom during operation

Note. Conduct a check on learning and summarize the learning activity.

4. Learning Step/Activity 4. Critique Students on Demonstration and PE 1.

Method of instruction: PE 1

Instructor to student ratio is: 1:2

Time of instruction: 0.2 hours

Media: SI

Instructor will use Kalmar RT-240 V2 Simulators and TM 10-3930-675-10-1 and TM 10-3930-675-10-2, and critique the Demonstration and PE 1.

Note. Conduct a check on learning and summarize the learning activity.

FEEDBACK REQUIREMENTS: Schedule and provide feedback on the PE and any information to help answer students questions. Provide remedial training as needed.

SOLUTION FOR PRACTICAL EXERCISE

Instructor will ensure that the student is familiar with the Kalmar RT-240 V2. The student must also have knowledge of picking up and traveling with a loaded container from one, two, and three high, row two, longitudinal, and at a angle containers and be familiar with the safety and warnings concerning the operation of the Kalmar 53,000-pound RT-240 RTCH V2.

**PRACTICAL EXERCISE AND SOLUTIONS
WORKSHEET NUMBER SHEET 4 – PE 1**

Lifting and Transporting Containers

MOTIVATOR: Using personal experience or related story, explain why this lesson is important to the student.

TERMINAL LEARNING OBJECTIVE:

The instructor should inform the students of the following terminal learning objective (TLO) covered with this PE.

Action: The student will be knowledgeable of the responsibilities of the lifting and transporting containers with the Kalmar 53,000-pound RT-240 RTCH.

Condition: Given TM 10-3930-675-10-1, TM 10-3930-675-10-2, and a Kalmar 53,000-pound RT-240 RTCH. The student will demonstrate the knowledge of picking up and traveling with a loaded container. The student will also be familiar with the safety and warnings concerning the operation of the Kalmar 53,000-pound RT-240 RTCH.

Standards: To receive a “GO” for this lesson, the student will demonstrate the knowledge of picking up and traveling with a loaded container with the Kalmar 53,000-pound RT-240 RTCH and the student must correctly answer all check on learning questions.

SAFETY REQUIREMENTS:

- Instructor will use the safety annex 60 Rules of Safety for Operating Material Handling Equipment (MHE) and conduct Safety Briefing before operations begin each morning and maintain direct supervision throughout the day.
- Safety will be discussed and practiced throughout this lesson.
- Safety clothing (hard hats, gloves, and steel toed boots, hearing protection) will be worn at all times while performing these tasks.
- One Instructor will be with MHE at all times with one student without TA 50. Student will sound warning before movement. Back only with ground guides using 3-point system. Look before backing and keep looking back until stopped. Never back long distances and never use mirrors for backing.

RISK ASSESSMENT LEVEL: Moderate.

ENVIRONMENTAL CONSIDERATIONS: It is the responsibility of all Soldiers and DA civilians to protect the environment from damage. AR 200-1 delineates TRADOC responsibilities to integrate environmental requirements across DOTMLPF and ensure all training procedures, training materials, and training doctrine, to include sound environmental practices and considerations. The Army’s environmental standard is to be a national leader in environmental and natural resource stewardship for present and future generations. This training support package meets this standard.

EVALUATION: Inform the Soldiers how, when, and where performance of the TLO will be evaluated. This lesson is examinable under performance test.

INSTRUCTIONAL LEAD IN: Transition students to presentation using personal experience or related story explain why this lesson is important to the students.

RESOURCE REQUIREMENTS: Kalmar RT-240 RTCH (based on the equipment to student ratio of 1:2).

SPECIAL INSTRUCTIONS: Instructor will have students perform preventive maintenance checks and services on each Kalmar RT-240 RTCH before operations begin.

PROCEDURES: Perform PE: Demonstrate operation under usual conditions.

1. Learning Step/Activity 1. Operation Under Usual Conditions.

Method of instruction: PE

Instructor to student ratio is: 1:2

Time of instruction: 2.0 hours

Media: TD or SI

Instructor will use TM 10-3930-675-10-1, TM 10-3930-675-10-2, and WP 0005 00-7 thru –19 to demonstrate to students the necessary Joystick movements to pick-up one high container. Checking indicators, and electronic control system display screen. Avoid over Steering and Hard Braking. Operate Boom and Control of Tophandler with Joystick operation. Boom Load Range; Field of view, position of Tophandler and boom during movement operation.

Note. Conduct a check on learning and summarize the learning activity.

PROCEDURES: Perform PE: Operation under usual conditions.

2. Learning Step/Activity 2. Operation Under Usual Conditions.

Method of instruction: PE

Instructor to student ratio is: 1:2

Time of instruction: 13.0 hours

Media: TD or SI

Instructor will have student use TM 10-3930-675-10-1, TM 10-3930-675-10-2, WP 0005 00-7 thru –19 to allow students to pick-up one high containers. Checking indicators, and electronic control system display screen. Avoid over Steering and Hard Braking. Operate Boom and Control of Tophandler with Joystick operation. Boom Load Range; Field of view, position of Tophandler and boom during operation.

Note. Conduct a check on learning and summarize the learning activity.

PROCEDURES: Perform PE: Demonstrate operation under unusual conditions.

3. Learning Step/Activity 3. Operation Under Unusual Conditions.

Method of instruction: PE

Instructor to student ratio is: 1:2

Time of instruction: 2.0 hours

Media: TD or SI

Instructor will use TM 10-3930-675-10-1, TM 10-3930-675-10-2, WP 0005 00-7 thru –19 to allow students to drive the Kalmar RT-240 RTCH to demonstrate the necessary Joystick movements to

pick-up two and three high containers. Under Usual Conditions, load/off load, stack containers two and three high, and place containers within load range reach in row two following all indicators, electronic control system display screen and Kalmar RT-240 RTCH limitations. Using Hand and arm signals in row two and three high operations. Avoid over Steering and Hard Braking. Field of view, position of Tophandler and boom during movement operation.

Note. Conduct a check on learning and summarize the learning activity.

PROCEDURES: Perform PE: Operation under usual conditions with container loaded on tophandler. Off loading/stacking containers two and three high, boom reach and load range in row one and row two.

4. Learning Step/Activity 4. Loading/Stacking Containers Two and Three High.

Method of instruction: PE

Instructor to student ratio is: 1:2

Time of instruction: 6.8 hours

Media: TD or SI

Instructor will use TM 10-3930-675-10-1, TM 10-3930-675-10-2, WP 0005 00-7 thru –22 to allow students to drive the Kalmar RT-240 RTCH with container loaded on tophandler. Under Usual Conditions, the student will load/off load, stack containers two and three high, and place containers within load range reach in row one and two following all indicators, electronic control system display screen and Kalmar RT-240 RTCH limitations. Using Hand and arm signals in row two and three high operations. Operate Boom and Control of Tophandler with Joystick operation Avoid over Steering and Hard Braking. Field of view, position of Tophandler and boom during operation.

Note. Conduct a check on learning and summarize the learning activity.

PROCEDURES: Perform PE: Off load and stack containers.

5. Learning Step/Activity 5. Off Load and Stack Containers.

Method of instruction: PE

Instructor to student ratio is: 1:2

Time of instruction: 8.0 hours

Media: TD or SI

Instructor will use TM 10-3930-675-10-1, TM 10-3930-675-10-2, WP 0005 00-7 thru –19 to allow students to pick-up one high, row one, longitudinal, and at an angle containers. Check indicators, and electronic systems control display screen. Operate Boom and Control of Tophandler with Joystick operation. Boom Load Range; Field of view, position of Tophandler and boom during operation.

Note. Conduct a check on learning and summarize the learning activity.

PROCEDURES: Perform demonstration by critiquing students on demonstration and PE 1.

6. Learning Step/Activity 6. Critique Students on Demonstration and PE 1.

Method of instruction: PE

Instructor to student ratio is: 1:2

Time of instruction: .2 hours

Media: TD or SI

Instructor will use Kalmar RT-240 RTCH and critique the Demonstration and PE 1

Note. Conduct a check on learning and summarize the learning activity.

FEEDBACK REQUIREMENTS: Schedule and provide feedback on the PE and any information to help answer student's questions. Provide remedial training as needed.

SOLUTION FOR PRACTICAL EXERCISE SHEET 4 – KALMAR RT-240 RTCH

Instructor will ensure that the student is familiar with the preventive maintenance checks and services. Students will also have the knowledge of picking up and traveling with a loaded container from one two and three high, row two, longitudinal, and at a angle containers and be familiar with the safety and warnings concerning the operation of the Kalmar 53,000-pound RT-240 RTCH.

Student Handouts

- TM 10-3930-675-10-1.
- TM 10-3930-675-10-2.
- DA Form 2404.
- Force Protection Annex 60 Rules of Safety for Operating Material Handling Equipment (MHE).

**PRACTICAL EXERCISE AND SOLUTIONS
WORKSHEET NUMBER SHEET 5 - PE 1**

Placing Cab and Boom in the Transport Mode

MOTIVATOR: Using personal experience or related story, explain why this lesson is important to the student.

TERMINAL LEARNING OBJECTIVE: To become familiar with the Operation Under Unusual Conditions of the Kalmar RT-240 RTCH.

Note. The instructor should inform the students of the following terminal learning objective (TLO) covered with this PE. At the completion of this lesson, you (the student) will:

Action: Be knowledgeable of the responsibilities of the Kalmar RT-240 RTCH operation and skills of the controls and instruments. To prepare the Kalmar RT-240 RTCH for aircraft transport and install the Forklift Kit.

Conditions: Given TM 10-3930-675-10-1, TM 10-3930-675-10-2, and Kalmar 53,000-pound RT-240 RTCH. You (the student) will place the Cab and Boom in transport position for aircraft loading or deployment and install the Forklift Kit.

Standard: To receive a "GO" for this lesson, the student will be familiar with the lifting and transporting containers, with the Kalmar 53,000-pound RT-240 RTCH Under Unusual Conditions, student will be able to accomplish the task of placing the cab and boom in the transport mode, and of installing the Forklift Kit.

SAFETY REQUIREMENTS:

- Instructor will use the safety annex 60 Rules of Safety for Operating Material Handling Equipment (MHE) and conduct Safety Briefing before operations begin each morning and maintain direct supervision throughout the day.
- Safety will be discussed and practiced throughout this lesson.
- Safety clothing (hard hats, gloves, and steel toed boots, hearing protection) will be worn at all times while performing these tasks.
- One Instructor will be with MHE at all times with one student without TA 50. Student will sound warning before movement. Back only with ground guides using 3-point system. Look before backing and keep looking back until stopped. Never back long distances and never use mirrors for backing.

RISK ASSESSMENT LEVEL: Moderate.

ENVIRONMENTAL CONSIDERATIONS: It is the responsibility of all Soldiers and DA civilians to protect the environment from damage. AR 200-1 delineates TRADOC responsibilities to integrate environmental requirements across DOTMLPF and ensure all training procedures, training materials, and training doctrine, to include sound environmental practices and considerations. The Army's environmental standard is to be a national leader in environmental and natural resource stewardship for present and future generations. This training support package meets this standard.

EVALUATION: Inform the Soldiers how, when, and where performance of the TLO will be evaluated. This lesson is examinable under performance test.

INSTRUCTIONAL LEAD IN: Transition students to presentation using personal experience or related story explain why this lesson is important to the students.

RESOURCE REQUIREMENTS:

- Rough Terrain Container Handler - 2 each.
- Kalmar RT-240 Forklift Kit - 2 each.

SPECIAL INSTRUCTIONS: Instructor will have students perform preventive maintenance checks and services on each Kalmar RT-240 RTCH before operations begin.

PROCEDURES: Perform PE: Instructor will have student install the forklift kit.

1. Learning Step/Activity 1. Install Forklift Kit.

Method of instruction: PE

Instructor to student ratio is: 1:2

Time of instruction: 2.0 hours

Media: TD

Students will use TM 10-3930-675-10-1, TM 10-3930-675-10-2, WP 0005 00-25 thru 31 to perform Crew/Operator installation of the Forklift Kit. Install the Forklift Kit and demonstrate the lifting and moving of a MILVAN. Record all deficiencies and shortcomings on DA Form 2404 (Equipment Inspection and Maintenance Worksheet).

Note. Conduct a check on learning and summarize the learning activity.

PROCEDURES: Perform PE: Instructor will have student place the cab and boom in transport position for aircraft loading or deployment.

2. Learning Step/Activity 2. Place the Cab and Boom in Transport Position.

Method of instruction: PE

Instructor to student ratio is: 1:2

Time of instruction: 5.8 hours

Media: TD

Students will use TM 10-3930-675-10-1, TM 10-3930-675-10-2, WP 0007 00-1 thru 19 to perform Crew/Operator placement of the Cab and Boom in transport position for aircraft loading or deployment. Record all deficiencies and shortcomings on DA Form 2404 (Equipment Inspection and Maintenance Worksheet).

PROCEDURES: Perform PE by critiquing students on PE.

3. Learning Step/Activity 3. Critique Students on Practical Exercise.

Method of instruction: PE

Instructor to student ratio is: 1:2

Time of instruction: .2 hours

Media: TD

Instructor will use Kalmar RT-240 RTCH and Forklift Kit to critique the PE.

Note. Conduct a check on learning and summarize the learning activity.

FEEDBACK REQUIREMENTS: Schedule and provide feedback on the PE and any information to help answer student's questions. Provide remedial training as needed.

**SOLUTION FOR PRACTICAL EXERCISE
PE SHEET 5 – KALMAR RT-240 RTCH**

Placing Cab and Boom in the Transport Mode

Instructor will ensure that the student is familiar with the Placement of the Cab and Boom in transport position for aircraft loading or deployment and the installation of the Forklift Kit. Using TM 10-3930-675-10-1 and TM 10-3930-675-10-2, WP 0007 00-1 thru -19 and WP 0005 00-25 thru -31.

Student Handouts

- TM 10-3930-675-10-1.
- TM 10-3930-675-10-2.
- DA Form 2404.
- 60 Rules of Safety for Operating Material Handling Equipment (MHE) (Appendix C).

Appendix E

HANDOUTS AND WORKSHEETS

Handout # 1

ENGINE STARTING AND DRIVING**INITIAL ADJUSTMENTS, DAILY CHECKS, AND SELF-TEST OF KALMAR RT-240 RTCH**

1. Battery Switch, place master battery switch to ON.
2. Perform before-operations preventive maintenance checks and services (PMCS).
3. Occupy and adjust seat.
4. Close cab door.
5. Adjust position of joystick.
6. Adjust rearview mirror as required.
7. Adjust steering wheel and column.
8. Fasten seat belt.

START ENGINE

1. Ensure that parking brake is applied.
2. Place transmission shift control lever to Neutral (N).
3. Ensure that all accessory switches and controls are in the OFF position.
4. Turn ignition switch to ON position. System warning lights will illuminate briefly, and then go out.
5. If ambient temperature is below 32° F, press ether injector switch on instrument panel.

Note. DO NOT operate the starter motor for more than 30 seconds at a time. After 30 seconds, allow starter motor to cool for at least two minutes before attempting to start engine again. Excessive heating of starter motor may result in damage or early starter failure.

6. Turn ignition switch to START and allow the engine to start and run at idle speed.

Note. Start the engine with throttle in the IDLE position. It is not necessary to press the throttle to start a computer-controlled engine.

7. Increase the engine speed (RPMs) slowly to provide adequate lubrication to the bearings and allow the oil pressure to stabilize.
8. Run engine at idle speed for 3 to 5 minutes before operating with a load.

9. Monitor fuel gauge and indicators for any signs of abnormal temperatures or pressures. Shut down engine at first sign of a problem.

- a. Engine oil pressure—15 psi to 35 psi (103 kPa to 241 kPa).
- b. Engine oil temperature—195° F to 240° F (91° C to 116° C).
- c. Transmission temperature—175° F to 220° F (79° C to 104° C).
- d. Hydraulic oil temperature—below 160° F (71° C).
- e. Coolant temperature—175° F to 210° F (79° C to 99° C).
- f. Ensure alternator charging lamp is not lit.

OPERATE TRANSMISSION

- 1. Depress and hold brake pedal.
- 2. Release parking brake.
- 3. Select direction and gear range with transmission control lever.

Note. When a lower transmission range or gear is selected, the transmission may not downshift until vehicle speed is reduced.

Note. ALWAYS bring the truck to a complete STOP before changing from forward to reverse to prevent possible damage to the transmission.

- 4. Release brake pedal and begin to move truck.

<p>WARNING</p> <p>NEVER LEAVE THE OPERATOR'S POSITION WITHOUT APPLYING THE PARKING BRAKE. FAILURE TO FOLLOW THIS WARNING MAY RESULT IN DEATH OR INJURY TO PERSONNEL OR DAMAGE TO EQUIPMENT.</p>

DRIVING TIPS FOR KALMER RT-240 RTCH

Note. DO NOT allow riders on the truck. Failure to follow this warning may result in serious injury or death to personnel.

- Truck must not be driven when container load is in fully raised position. Truck is less stable when traveling with the load in a raised position. Always position the bottom of the load just above the driver's field of view, with the boom fully retracted. Failure to follow this warning may result in serious injury or death to personnel.

- BE ALERT for personnel in area while operating truck. Always check to ensure area is clear of personnel and obstructions before moving. Failure to follow this warning may result in serious injury or death to personnel.
1. Check Fuel Gauge, Indicators, and ECS Display Screen Frequently. If indicators show an abnormal reading or warning light comes on, bring the truck to a safe stop, shut down engine, and investigate cause.
 2. Avoid Over Steering. Become familiar with steering characteristics of truck before attempting maneuvers in limited space.
 3. Avoid Hard Braking. Become familiar with the braking characteristics of the truck with and without a load.
 4. Field of View. When driving without a load, position the tophandler above your field of view, with the boom fully retracted. When driving with a load, position the bottom of the load above your field of view, with the boom fully retracted.

DRIVING

1. Perform initial seat and steering column adjustments.
2. Perform daily checks and self-tests.
3. Start engine and allow it to come up to operating temperature (175° F).
4. Raise tophandler to driving position.
5. With engine at idle, apply service brakes.
6. Select steering mode of operation by first straightening wheels, then pressing desired steering selection switch.
7. Move transmission control lever to desired direction, F or R, and select gear range.
8. Release parking brake lever and depress accelerator pedal to control truck speed.
9. Engage oscillation and tilt locks before driving with a load.

The Kalmar RT-240 RTCH ECU continuously monitors the boom angle, boom extension, and pressure in the hydraulic lift cylinders. From this data the computer calculates the actual load. This information is compared to the allowed load at the current position. When 100 percent capacity is reached, the system cuts off and will not allow any more movement, except to retract).

Handout # 2

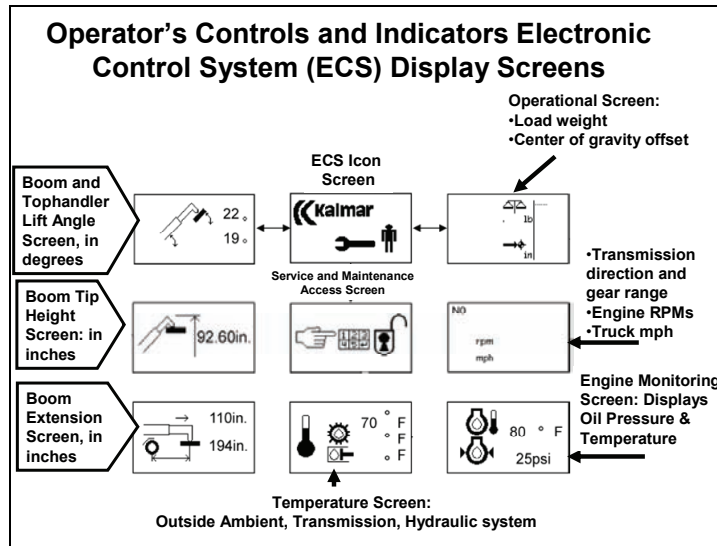

Handout # 3

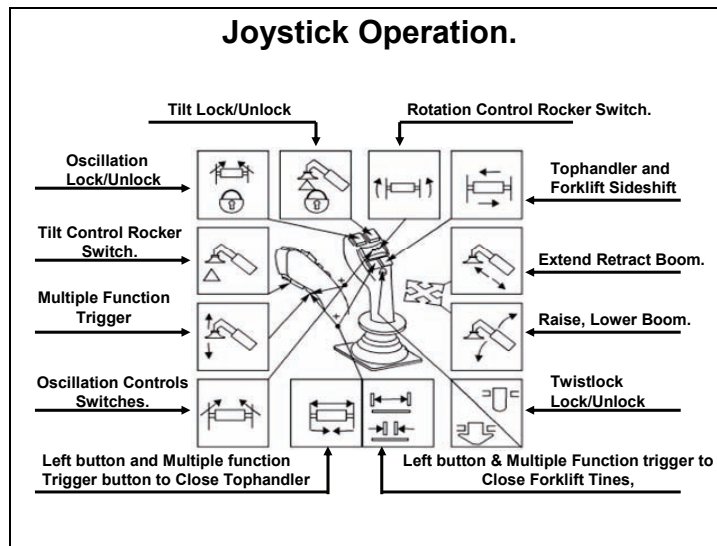

Worksheet # 1

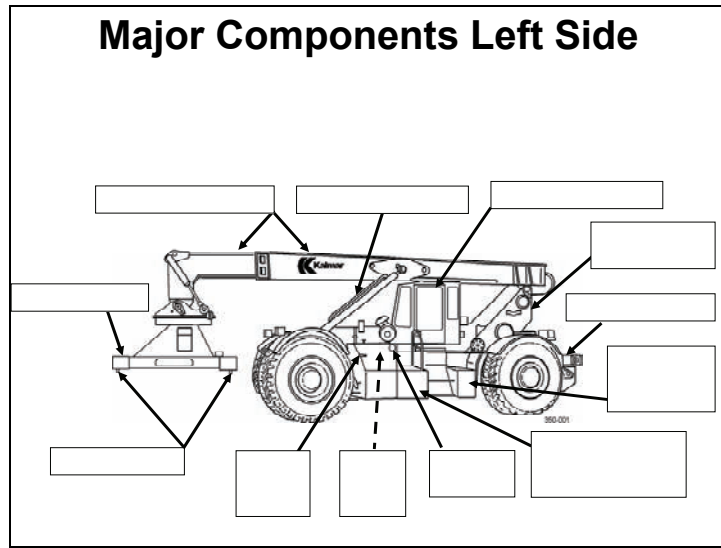

Worksheet # 2

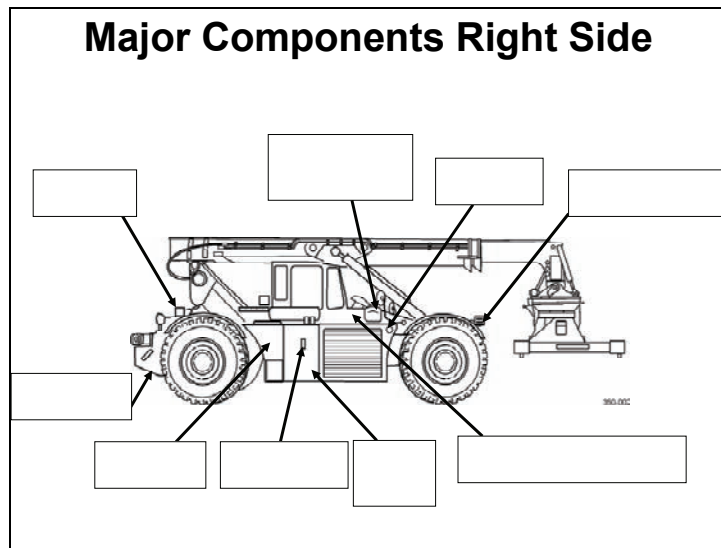

Worksheet # 3

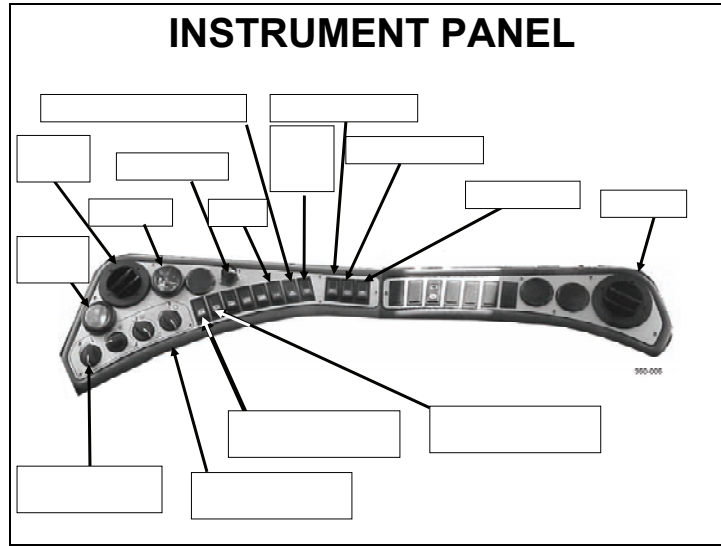

Worksheet # 4

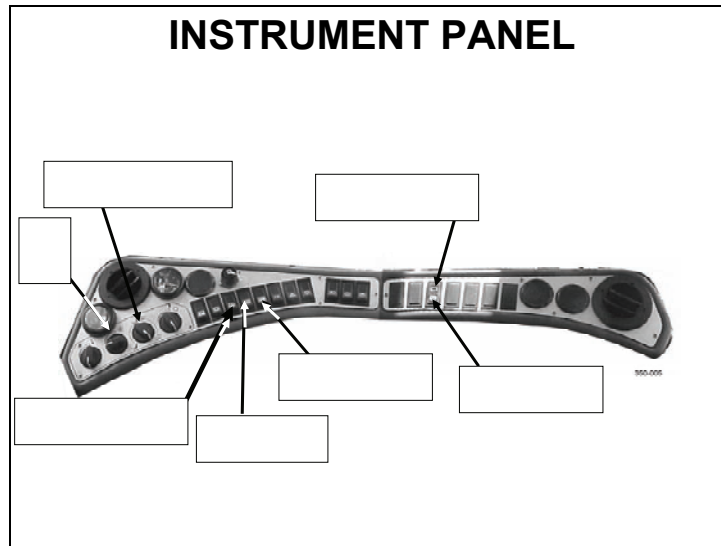

Worksheet # 5

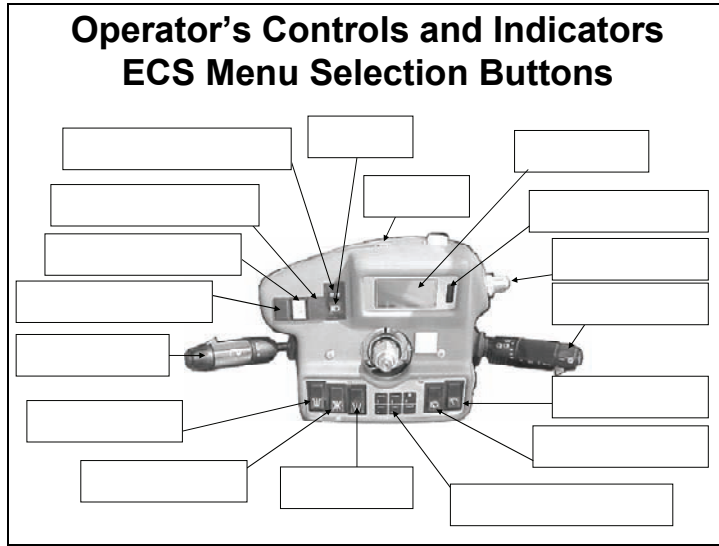

Worksheet # 6

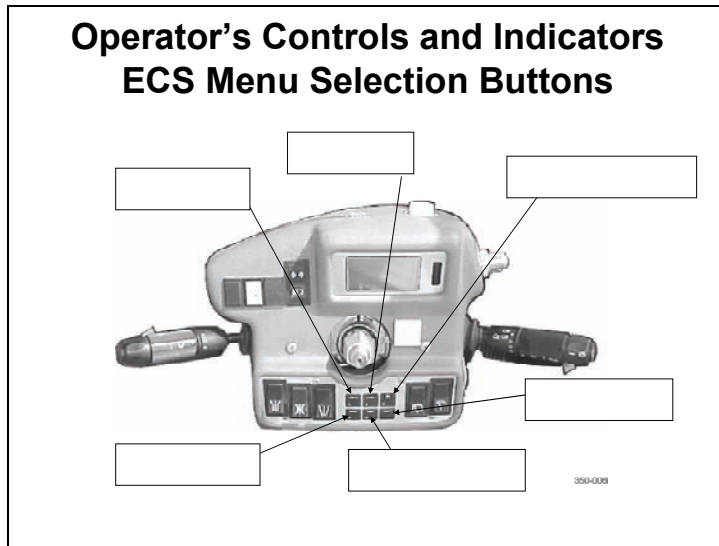

Worksheet # 7

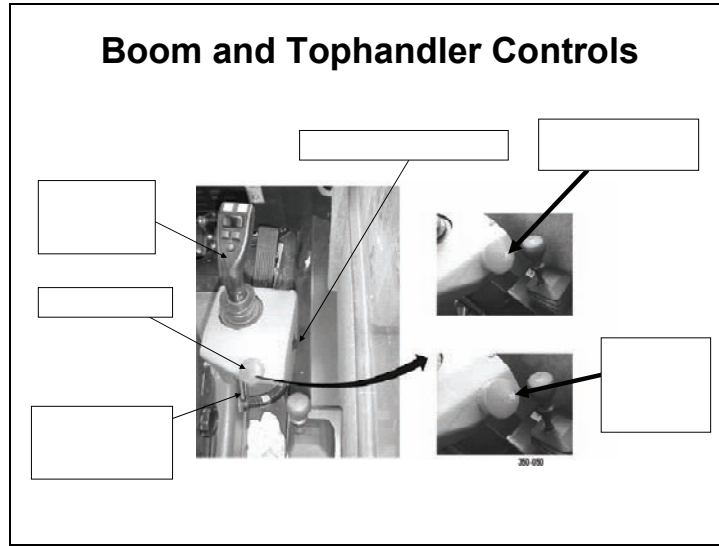

Worksheet # 8

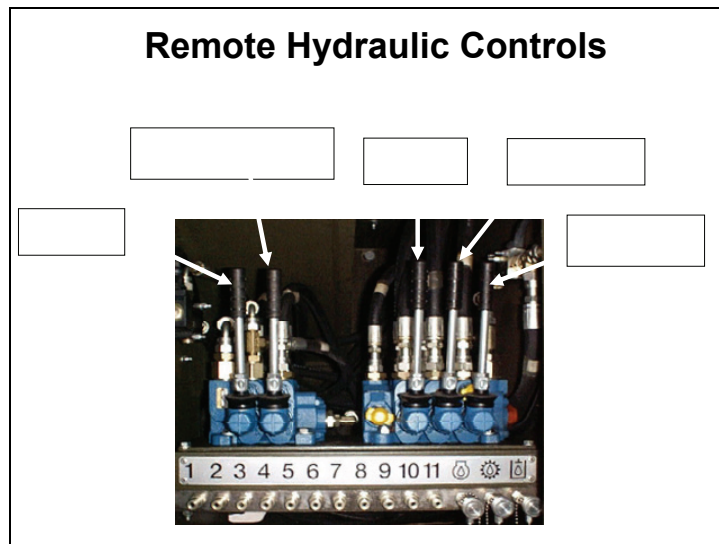

Glossary

A/C	air conditioning
AFMAN	Air Force manual
AOR	area of responsibility
AR	Army regulation
ATTN	attention
BII	basic issue items
C	Celsius
CAD	course administrative data
CARC	chemical agent resistant coating
CFR	Code of Federal Regulation
CLS	combat lifesaver
C/MHE	container and materials handling equipment
COA	course of action
CPR	cardiopulmonary resuscitation
CRM	composite risk management
D.C.	District of Columbia
DA	Department of the Army
DC	direct current
DD	Department of Defense
DODI	Department of Defense Instruction
DOL	Directorate of Logistics
DOTMLPF	Doctrine, Organization, Training, Materiel, Leadership and Education, Personnel and Facilities
DVD	digital versatile disc
ECM	electronic control module
ECS	Electronic Control System
ELO	enabling learning objective
ESC	Electronic Stability Control
ECU	electronic control unit
F	Fahrenheit
FM	field manual
GVWR	gross vehicle weight rating
HAZCOM	hazard communication
hp	horsepower
HQ	Headquarters
ID	identification
IR	infrared
ISO	International Organization for Standardization

km	kilometer(s)
kPa	kilopascal
kph	kilometers per hour
KRTC	Kalmar Rough Terrain Center
L	length
LB	pound(s)
LBE/V	load-bearing equipment/vest
LO	lubrication order
MAX	maximum
MDMP	military decision making process
METT-T	mission, enemy, terrain and weather, troops and support available--time available
MHE	material handling equipment
MILVAN	military-owned demountable container
MIN	minimum
MPH	miles per hour
MSDS	Material Safety Data Sheet
MTT	Mobile Training Team
N	neutral
NATO	North Atlantic Treaty Organization
NBC	nuclear, biological, chemical
NC	North Carolina
NCO	noncommissioned officer
No.	number
OALH	overall lowered height
OF	optional form
OSHA	Occupational Safety and Health Administration
PAM	pamphlet
PE	practical exercise
PM	product manager
PMCS	preventive maintenance checks and services
POI	Program of Instruction
PPE	personal protective equipment
psi	pounds per square inch
RPM	revolutions per minute
RTCH	rough terrain container handler
S-TON	short ton
SOP	standing operating procedure
SSN	social security number
TC	training circular
TLO	terminal learning objective
TM	technical manual

TRADOC	Training and Doctrine Command
U.S.	United States
USACASCOM	United States Army Combined Arms Command
VA	Virginia
W	width

This page intentionally left blank.

References

REQUIRED PUBLICATIONS

Required publications are sources that users must read in order to understand or to comply with this publication.

ARMY REGULATIONS

AR 70-1. *Army Acquisition Policy*, 31 December 2003

AR 200-1. *Environmental Protection and Enhancement*, 13 December 2007

AR 385-10. *The Army Safety Program*, 23 August 2007

AR 600-8-104. *Military Personnel Information Management/Records*, 22 June 2004

AR 600-55. *The Army Driver and Operator Standardization Program (Selection, Training, Testing, and Licensing)*, 18 June 2007

AR 611-5. *Personnel and Classification Testing*, 5 February 2008

DEPARTMENT OF ARMY FORMS

DA forms are available from the APD website at <https://myforms.us.army.mil/wps/myportal>.

DA Form 348, *Equipment Operator's Qualification Record (Except Aircraft)*

DA Form 348-E, *Operator Qualification Record*

DA Form 2028, *Recommended Changes to Publications and Blank Forms*

DA Form 2404, *Equipment Inspection and Maintenance Worksheet*

DA Form 5987-E, *Motor Equipment Dispatch (EGA)*

DA Form 5988-E, *Equipment Inspection Maintenance Worksheet (EGA)*

DA Form 7566, *Composite Risk Management Worksheet*

DEPARTMENT OF DEFENSE FORMS

DD forms are available from the OSD website at

<http://www.dtic.mil/whs/directives/infomgt/forms/formsprogram.htm>.

DD Form 1902, *Certificate of Qualification*

DD Form 1970, *Motor Equipment Utilization Record*

DEPARTMENT OF THE ARMY PAMPHLETS

DA PAM 750-8, *The Army Maintenance Management System (TAMMS) Users Manual*, 22 August 2005

FIELD MANUALS

FM 5-0, *Army Planning and Orders Production*, 20 January 2005

FM 5-19, *Composite Risk Management*, 21 August 2006

FM 21-60, *Visual Signals*, 30 September 1987

FM 21-305, *Manual for the Wheeled Vehicle Driver {AFMAN 24-306}*, 27 August 1993

FM 55-17, *Cargo Specialists' Handbook*, 16 February 1999

LUBRICATION ORDERS

LO 10-3930-675-12, *Rough Terrain Container Handler (RTCH): RT 240; 53,000 LB Capacity; 4X4 (NSN 3930-01-473-3998)*, 1 July 2001

OTHER SOURCES

CFR 29, *Labor*, 1 July 2007 (<http://www.gpoaccess.gov/CFR/INDEX.HTML>)

DODI 6050.05, *DOD Hazard Communication (HAZCOM) Program*, 15 August 2006

Executive Order 12196, *Occupational Safety and Health Programs for Federal Employees*, 26 February 1980

OF Form 346, *U.S. Government Motor Vehicle Operator's Identification Card*

SOLDIER TRAINING PUBLICATIONS

STP 55-88H14-SM-TG *Soldier's Manual and Trainer's Guide, MOS 88H, Cargo Specialist, Skill Levels 1, 2, 3, and 4*, 18 December 2007

TECHNICAL BULLETINS

TB 600-2, *Procedures for Selection, Training, Testing, Qualifying and Licensing Operators of Construction Equipment, Materiel Handling Equipment and Armor-Vehicle-Launched Bridge (AVLB) Managed/Supported by US Army Tank-Automotive Materiel Readiness Command*, 28 June 1979

TECHNICAL MANUALS

TM 10-3930-675-10-1 *Operator's Manual for Rough Terrain Container Handler (RTCH): RT 240; 53,000 LB Capacity; 4 X 4 (NSN 3930-01-473-3998) Rough Terrain Container Handler (RTCH): RT 240; 53,000 LB Capacity; 4 X 4 (Reset) (NSN 3930-01-473-3998) Rough Terrain Container Handler (RTCH): RT 240V2; 53,000 LB Capacity; 4 X 4 (NSN 3930-01-522-7364)*, 1 December 2006

TM 10-3930-675-10-2 *Operator's Manual for Rough Terrain Container Handler (RTCH): RT 240; 53,000 LB Capacity; 4 X 4 (NSN 3930-01-473-3998) Rough Terrain Container Handler (RTCH): RT 240; 53,000 LB Capacity; 4 X 4 (Reset) (NSN 3930-01-473-3998) Rough Terrain Container Handler (RTCH): RT 240V2; 53,000 LB Capacity; 4 X 4 (NSN 3930-01-522-7364)*, 1 December 2006

TRAINING CIRCULARS

TC 21-305, *Training Program for Wheeled Vehicle Accident Avoidance*, 19 August 1996

TC 55-60-18
10 October 2008

By Order of the Secretary of the Army:

GEORGE W. CASEY, JR.
General, United States Army
Chief of Staff

Official:

A handwritten signature in black ink that reads "Joyce E. Morrow". The signature is written in a cursive style with a large initial "J" and "M".

JOYCE E. MORROW
Administrative Assistant to the
Secretary of the Army
0826301

DISTRIBUTION:

Active Army, Army National Guard, and United States Army Reserve: To be distributed in electronic media only.

