

**Army Regulation 70–47**

**Research, Development, and Acquisition**

# **Engineering for Transportability Program**

**Headquarters  
Department of the Army  
Washington, DC  
11 September 2012**

**UNCLASSIFIED**

# ***SUMMARY of CHANGE***

AR 70-47

Engineering for Transportability Program

This major revision, dated 11 September 2012-

- o Changes the title from Engineering for Transportability to Engineering for Transportability Program (cover).
- o Provides specific time requirements for notification of testing, submission of transportability reports, and approvals (paras 2-4 and 2-9).
- o Updates the publication to reflect current policy, procedures, and organizations (throughout).
- o Adds MIL-HDBK-1791 standards (throughout).
- o Updates and defines the roles and responsibilities of the materiel developers, the capability developers, testers, and the Military Surface Deployment and Distribution Command in the Army's Engineering for Transportability Program (throughout).

Research, Development, and Acquisition

Engineering for Transportability Program

By Order of the Secretary of the Army: States, and the U.S. Army Reserve, unless otherwise stated.

RAYMOND T. ODIERNO  
General, United States Army  
Chief of Staff

Official:

  
JOYCE E. MORROW  
Administrative Assistant to the  
Secretary of the Army

**History.** This publication is a major revision.

**Summary.** This regulation covers the Department of the Army policy for transportability engineering in the acquisition process. This policy implements key provisions of DODD 4510.11, DODD 5000.01, DODI 4540.07, and DODI 5000.02.

**Applicability.** This regulation applies to the Active Army, the Army National Guard/Army National Guard of the United

**Proponent and exception authority.** The proponent of this regulation is the Assistant Secretary of the Army for Acquisition, Logistics and Technology. The proponent has the authority to approve exceptions or waivers to this regulation that are consistent with the controlling law and regulations. The proponent may delegate this approval authority, in writing, to a division chief within the proponent agency or its direct reporting unit or field operating agency, in the grade of colonel or the civilian equivalent. Activities may request a waiver to this regulation by providing justification that includes a full analysis of the expected benefits and must include formal review by the activity's senior legal officer. All waiver requests will be endorsed by the commander or senior leader of the requesting activity and forwarded through higher headquarters to the policy proponent. Refer to AR 25–30 for specific guidance.

**Army internal control process.** This regulation contains internal control provisions in accordance with AR 11–2 and identifies key internal controls that must be evaluated (see appendix D).

**Supplementation.** Supplementation of this regulation and establishment of command and local forms are prohibited without prior approval from the Deputy Assistant Secretary of the Army (Acquisition Policy and Logistics) (SAAL–ZL), 103 Army Pentagon, Washington, DC 20310-0103.

**Suggested improvements.** Users are invited to send comments and suggested improvements on DA Form 2028 (Recommended Changes to Publications and Blank Forms) directly to the Deputy Assistant Secretary of the Army (Acquisition Policy and Logistics) (SAAL–ZL), 103 Army Pentagon, Washington, DC 20310-0103.

**Distribution.** This publication is available in electronic media only and is intended for command levels C, D, and E for the Active Army, the Army National Guard/Army National Guard of the United States, and the U.S. Army Reserve.

**Contents** (Listed by paragraph and page number)

**Chapter 1**

**Introduction, page 1**

*Section I*

*General, page 1*

Purpose • 1–1, *page 1*

References • 1–2, *page 1*

Abbreviations and terms • 1–3, *page 1*

Responsibilities • 1–4, *page 1*

Policy guidelines • 1–5, *page 1*

*Section II*

*Responsibilities, page 1*

\*This regulation supersedes AR 70–47, 19 August 1985.

## **Contents—Continued**

The Assistant Secretary of the Army (Acquisition, Logistics and Technology) • 1–6, *page 1*  
The Assistant Secretary of the Army (Installations, Energy and Environment) • 1–7, *page 1*  
The Deputy Chief of Staff, G–4 • 1–8, *page 2*  
The Deputy Chief of Staff, G–3/5/7 • 1–9, *page 2*  
The Commanding General, U.S. Army Materiel Command • 1–10, *page 2*  
The Commander, U.S. Army Natick Soldier, Research, Development and Engineering Center • 1–11, *page 2*  
The Commander, Military Surface Deployment and Distribution Command • 1–12, *page 2*  
The Director, Military Surface Deployment and Distribution Command Transportation Engineering Agency • 1–13, *page 3*  
The Commander, U.S. Army Training and Doctrine Command • 1–14, *page 3*  
The Chief, National Guard Bureau • 1–15, *page 4*  
The Chief, Army Reserve • 1–16, *page 4*  
The Commander, U.S. Army Test and Evaluation Command • 1–17, *page 4*  
Materiel developers • 1–18, *page 4*

## **Chapter 2**

### **Transportability Engineering in the Acquisition Process, *page 5***

Transportation program requirements • 2–1, *page 5*  
Coordination • 2–2, *page 5*  
Materiel capability documents • 2–3, *page 5*  
Transportability reports • 2–4, *page 6*  
Unit deployment analyses • 2–5, *page 6*  
Airdrop and air transport • 2–6, *page 6*  
Transportability testing • 2–7, *page 7*  
Transportation Engineering Agency instructions • 2–8, *page 7*  
Transportability approvals • 2–9, *page 7*

## **Appendixes**

- A.** References, *page 8*
- B.** Format For Transportability Report, *page 9*
- C.** Checklist of Transportability Actions, *page 21*
- D.** Internal Control Evaluation, *page 22*

## **Glossary**

# Chapter 1 Introduction

## Section I General

### 1–1. Purpose

This regulation sets policy for the Engineering for Transportability Program, requirements for transportability assessment, and approvals for transportability problem items (TPIs). TPIs are materiel in its shipping configuration which, because of its size, weight, fragile, or hazardous characteristics or lack of adequate means for lifting and tiedown, will be denied movement, will require special permits or waivers and special equipment or handling, or will be unacceptably delayed when moving within existing or newly designed transportation systems.

### 1–2. References

Required and related publications and prescribed and referenced forms are listed in appendix A.

### 1–3. Abbreviations and terms

Abbreviations and special terms used in this regulation are explained in the glossary.

### 1–4. Responsibilities

Responsibilities are listed in section II of chapter 1.

### 1–5. Policy guidelines

a. This policy—

(1) Applies to all Army materiel (major end items, components, and spare parts) to include: research, development, test, and evaluation (RDT&E) systems; product improvements (including materiel modifications and upgrades); commercial items and military-adapted commercial items; foreign source items; nondevelopmental items; rapidly fielded equipment; reprocurments; and systems/equipment/munitions (SEM).

(2) Assigns responsibilities and prescribes procedures for the Engineering for Transportability Program.

(3) Provides Army materiel developer (MATDEV) and capability developer (CAPDEV) guidance and procedures for use during the materiel acquisition process. These procedures assure that all Army materiel (major end items, components, and spare parts) to include: RDT&E systems; product improvements; commercial items and military-adapted commercial items; foreign source items; nondevelopmental items; rapidly fielded equipment; reprocurments; and SEM are acquired, designed, engineered, and constructed so that required quantities can be moved efficiently by existing and planned transportation assets.

(4) Implements requirements as set forth in DODD 4510.11, DODI 4540.07, DODD 5000.01, and DODI 5000.02.

b. Materiel, regardless of its condition (for example, a battle damaged item), is considered a TPI when specific conditions apply (see TPI in the glossary terms section for applicable conditions).

c. A transportability nonproblem item (NPI) is materiel that does not qualify as a TPI. An example of an NPI is a vehicle that already has a transportability approval and only a radio is being updated within the vehicle. In this example, a new transportability approval is not required. NPIs do not require a transportability approval. However, if the item is determined to be a NPI, the Military Surface Deployment and Distribution Command Transportation Engineering Agency (SDDCTEA) will provide a NPI statement (a memorandum and an e-mail) to the MATDEV upon request. If design changes are made to a NPI that result in it becoming a TPI, any NPI statement provided by SDDCTEA for the item will become invalid and the transportability approval process in this regulation must be followed.

## Section II Responsibilities

### 1–6. The Assistant Secretary of the Army (Acquisition, Logistics and Technology)

The ASA (ALT) will—

a. Establish policy for the Engineering for Transportability Program.

b. Oversee the engineering for transportability function.

c. Ensure MATDEVs give adequate consideration of transportability during RDT&E of acquired materiel systems.

### 1–7. The Assistant Secretary of the Army (Installations, Energy and Environment)

The ASA (IE&E) will ensure that environmental and facility considerations impacting this policy are coordinated with the ASA (ALT).

### **1-8. The Deputy Chief of Staff, G-4**

The DCS, G-4 will review the Engineering for Transportability Program policy for impact to distribution operations.

### **1-9. The Deputy Chief of Staff, G-3/5/7**

The DCS, G-3/5/7 will assure that materiel requirements documents consider transportability before approval.

### **1-10. The Commanding General, U.S. Army Materiel Command**

The CG, AMC will—

- a.* Develop a command awareness of the Engineering for Transportability Program.
- b.* Ensure the Director, U.S. Army Defense Ammunition Center and School coordinates with SDDCTEA on the transportability of ground support equipment.
- c.* Determine, in cooperation with the U.S. Air Force (USAF) and the U.S. Army Training and Doctrine Command (TRADOC), detailed rigging procedures to be used by the Army for airdrop of materiel.
- d.* Determine, in cooperation with the USAF Air Transportability Test Loading Activity (ATTLA) and TRADOC, procedures to disassemble, load, restrain, and offload materiel for internal air transport (IAT) for fixed-wing aircraft.
- e.* Develop trial rigging equipment procedures and instructions for internal Army helicopter air transport or external helicopter sling loading.
- f.* Develop blocking, bracing, slinging, lifting, and tiedown procedures to assure safe, economical, logistical, and tactical transport.
- g.* Conduct developmental tests to demonstrate the degree to which requirements and procedures have been met for—
  - (1) Airdrop for ancillary airdrop equipment.
  - (2) IAT of materiel (disassemble, load, restrain, and offload materiel).
  - (3) Internal Army helicopter air transport or external helicopter sling loading trial rigging equipment.
  - (4) Blocking, bracing, slinging, lifting, and tiedown.
  - (5) Materiel for containerization.
  - (6) Transport by lighterage, Army intra-theater water transport platforms, and amphibious landing craft.
- h.* Provide land transportability testing when requested by other Department of Defense (DOD) transportability agents.
- i.* Develop and obtain approval for out-loading drawings for ammunition commodities and missile and rocket ground support equipment.
- j.* Assist SDDCTEA in the collection of transportability characteristics data for Army end items of equipment for inclusion in technical bulletin (TB) 55-46-1 and TB 55-46-2.
- k.* Furnish SDDCTEA the transportability characteristics data for all items of equipment under AMC management for inclusion in TB 55-46-1 and TB 55-46-2.
- l.* Notify SDDCTEA of changes in materiel dimensions or weight resulting from product improvements and modifications.
- m.* Determine if commercial items require modification or special securing equipment to meet transportability requirements, including those necessary for logistics-over-the-shore (LOTS) and airborne operations.
- n.* Ensure the Director, AMC Packaging, Storage, and Containerization Center serves as the AMC focal point for the transportability packaging program for NPIs.

### **1-11. The Commander, U.S. Army Natick Soldier, Research, Development and Engineering Center**

The Commander, NSRDEC will—

- a.* Provide engineering and design assistance for materiel to be airdropped from fixed-winged aircraft and internally or externally transported by tilt-rotor or Army rotary-winged aircraft, and serve as the cargo airdrop and helicopter sling load subject matter expert for the DOD.
- b.* Issue official certifications for materiel to be airdropped from fixed-winged aircraft and internally or externally transported by tilt-rotor or Army rotary-winged aircraft.
- c.* Provide airdrop and helicopter certifications to SDDCTEA.
- d.* Provide shelter certifications for standard rigid-wall shelters as approved by the Joint Committee on Tactical Shelters, Collective Protection Liaison, (508) 233-4347, DSN 256-4347, nati-amsrd-nsc-ad-b@conus.army.mil or Web site <http://jocotas.natick.army.mil/>, who must also approve the use of nonstandard shelters.

### **1-12. The Commander, Military Surface Deployment and Distribution Command**

The Commander, SDDC will—

- a.* Serve as the Army transportability agent.
- b.* Participate in Army Systems Acquisition Review Council and in-process reviews (IPRs) when the materiel is considered a TPI.

c. Provide advice to the ASA (ALT) on transportability considerations and problems at Army Systems Acquisition Review Council reviews (see AR 70-1).

### **1-13. The Director, Military Surface Deployment and Distribution Command Transportation Engineering Agency**

The Director, SDDCTEA will—

a. Serve as the single point of contact for Army agencies in securing transportability engineering analysis and assistance, test loadings and transportability certifications, and/or approvals from the other Services.

b. Conduct a transportability engineering analysis, when required, for each item for which a transportability report is submitted.

c. Provide all transportability approvals and statements to Army developing and procuring agencies in support of materiel release and type classification (see AR 70-1 and AR 700-142).

d. Conduct unit deployability studies, when required.

e. Review justification of major system new starts, operational and organizational plans, letter of agreement, letter requirement, Joint Capability Integration and Development System capability documents, operational needs statement, Joint urgent operational need statements, specifications, and other requirements documents, such as the capability development document or capabilities production document. This review will assure that the transportability and transportation requirements are sufficiently addressed for systems to meet their mission and deployment requirements (see AR 71-9).

f. Convene meetings of Army transportability engineering and other Services' transportability focal points and arrange for working groups to resolve problems and provide guidance, as required.

g. Provide transportability assistance to special task forces, special study groups, or ad hoc groups assembled for system acquisition in accordance with AR 71-9.

h. Provide an Army transportability agent representative to support MATDEV's with source selection evaluation boards and IPRs for materiel systems that are TPIs.

i. Coordinate with DOD transportability agents to ensure Army requirements are considered for transportation systems under the DOD agents' control.

j. Review transportability sections of test and evaluation master plans (TEMPs) and materiel fielding plans for materiel that is a TPI.

k. Prepare and distribute transportability modal instructions.

l. Validate, in cooperation with the USAF ATTLA, the requirements of special assignment airlift missions required for air transportability test loadings.

m. Provide DOD representation on the Association of American Railroads' Open Top Car Loading Rules Committee.

n. Provide transportability engineering assistance and service to Army commands and agencies and to other DOD components.

o. Manage data collection and data input in the Department of Army Standard Equipment Transportability Characteristics database (see TB 55-46-1 and TB 55-46-2).

p. In coordination with the USAF, maintain and publish current listing of Army, USAF, and U.S. Marine Corps equipment certified for transport in the USAF Air Mobility Command and Civil Reserve Air Fleet aircraft (see TB 55-46-1 and TB 55-46-2).

q. Obtain air certification from USAF ATTLA.

### **1-14. The Commander, U.S. Army Training and Doctrine Command**

The Commander, TRADOC is the Army's principal CAPDEV. All CAPDEVs developing requirements for Army materiel that is subject to this policy will—

a. Ensure that strategic and tactical transportability requirements (including modal requirements) are adequately stated in materiel capability documents and coordinated with SDDCTEA. The required type of transportability (worldwide road, rail, air, water) together with any special requirements for airdrop and tactical transport will be explicitly stated in the capability documents, purchase descriptions, and in the item specifications.

b. Validate transportability requirements to ensure compliance with appropriate doctrine.

c. Assign transportability engineering focal points for TRADOC.

d. Ensure the completion of an initial transportability assessment of materiel under development and/or change during concept development.

e. Provide tentative basis of issue plan and data on selected systems to SDDCTEA in support of unit deployability studies.

f. Ensure operational aerial delivery testing is scheduled to include low velocity airdrop (LVAD), IAT, and helicopter sling load for validation of trial procedures.

g. Publish transport procedures and prepare adequate training courses and material.

*h.* Prepare, coordinate, and submit for publication, training literature on transport procedures for tactical unit movement of organic unit materiel.

*i.* Publish approved rigging procedures for airdrop and air transport (except nuclear).

#### **1–15. The Chief, National Guard Bureau**

The CNGB will provide support to the CAPDEVs in developing transportability requirements that are peculiar to the National Guard Bureau mission.

#### **1–16. The Chief, Army Reserve**

The CAR will provide support to the CAPDEVs in developing transportability requirements that are peculiar to Army Reserve mission.

#### **1–17. The Commander, U.S. Army Test and Evaluation Command**

The Commander, ATEC will manage the Army's continuous comprehensive evaluation and user testing programs.

#### **1–18. Materiel developers**

MATDEVs are responsible for ensuring transportability requirements are considered in all phases of development and that materiel systems are designed, engineered, and constructed in accordance with the requirements of the Engineering for Transportability Program. MATDEVs will—

- a.* Establish internal procedures and controls to implement this policy.
- b.* Assign transportability engineering focal points for the MATDEV.
- c.* Identify all materiel that qualifies as a TPI.
- d.* Identify all materiel that qualifies as an NPI. SDDCTEA will assist the MATDEV with the NPI determination as needed. The MATDEV should request that SDDCTEA provide a NPI statement to support a milestone decision. SDDCTEA will provide the NPI statement to the MATDEV that identifies the NPI.
- e.* Obtain transportability approval from SDDCTEA for rapidly fielded equipment items that are a TPI.
- f.* Prepare and submit a transportability report for TPIs to SDDCTEA and request transportability analysis and approval from SDDCTEA (see AR 70–1).
- g.* Conduct developmental tests of new or improved materiel to identify deficiencies and ensure compliance with transportability requirements.
- h.* Monitor TPIs until deficiencies are corrected and SDDCTEA issues transportability approval.
- i.* Provide support to SDDCTEA in development and update of SDDCTEA modal transport instructions.
- j.* Request SDDCTEA provide an Army transportability agent representative to support source selection evaluation boards and IPRs for materiel systems that are TPIs.
- k.* Incorporate transportability test requirements for TPIs in the TEMP in coordination with the CAPDEV, operational tester, Army acquisition logistician, and SDDCTEA.
- l.* Provide logistics management information related to transportability and transportation to SDDCTEA for update of the Department of the Army (DA) master file of standard equipment characteristics to support a low rate initial production decision (see AR 700–127).
- m.* If applicable, develop, document, and obtain approval of approved shipping configurations through packaging validation testing in accordance with AR 700–15.
- n.* Determine special operating and transport characteristics of the item that are unique to various types of Army units.
- o.* Conduct lifting and tiedown tests that meet requirements in military standard (MIL–STD)–209 and rail impact tests that meet the requirements in MIL–STD–810, as needed, as determined by SDDCTEA.
- p.* Provide support and engineering data to the NSRDEC for materiel to be air dropped from fixed-wing aircraft, internally or externally transported by rotary-wing aircraft, the V–22 Osprey tilt-rotor aircraft, and/or materiel that contains a rigid wall, nonstandard, or modified shelter.
- q.* Provide support and engineering data to the USAF ATTLA for materiel to be transported by fixed-wing aircraft.
- r.* Ensure transportability characteristics and procedures provided in the SDDCTEA transportability approval for the TPI are included in item preparation, loading, securing, and unloading procedures for shipment of the item by all appropriate modes of transport. Include all data and procedures in the equipment technical manuals.
- s.* If the item is an explosive, obtain DOD Ammunition and Explosives Interim and Final Hazard Classification in accordance with Joint TB 700–2.



## Chapter 2 Transportability Engineering in the Acquisition Process

### 2-1. Transportation program requirements

Transportation program requirements—

*a.* Transportability is a critical element of strategic and tactical deployment. Developing transportable equipment and combat resources that comply with this regulation will be an integral part of the acquisition process. Transportability requirements will be a primary design consideration by MATDEVs. The following requirements supplement those in DODI 4540.07:

*b.* Materiel will—

(1) Be designed for transport in USAF Air Mobility Command prime mission cargo aircraft when there is a fixed-wing air transport requirement (see military handbook (MIL-HDBK)-1791). Materiel limited to C-5 aircraft requires approval by appropriate headquarters DA staff elements.

(2) Meet State and Federal legal and operational standards for the design and use of public highways.

(3) Except for equipment that does not carry its payload during transport (such as wreckers, dump trucks, and material handling equipment), the item shall be designed (or procured) to carry their rated payload during all of its required transport modes (worldwide road, rail, air, water).

(4) Have a transportability and/or shipping data plate that will show tiedown and lifting points, locations, and strengths, and the location of the center of gravity (see MIL-STD-209).

(5) Comply with transportability criteria prescribed in MIL-HDBK-1791 and MIL-STD-1366.

(6) Comply with slinging and tiedown criteria prescribed in MIL-STD-209 and MIL-STD-913.

(7) Comply with airdrop criteria prescribed in MIL-STD-814 and MIL-HDBK-669.

### 2-2. Coordination

The following coordination will be performed for TPIs:

*a.* CAPDEVs, MATDEVs, testers, logisticians, and users will coordinate with SDDCTEA to ensure transportability considerations are assessed and ensure that requirements are met. Correspondence will be forwarded to Director, SDDCTEA (DPE), 1 Soldier Way, Scott Air Force Base (AFB), IL 62225-5006 for—

(1) Transportability guidance.

(2) Transportability reports.

(3) Requests for transportability approvals.

(4) Requests regarding technical and operational matters pertaining to the day-to-day operations of the engineering for transportability program.

(5) Requests for approval to add loading drawings to the Association of American Railroads rules governing the loading of vehicles and/or equipment on open top railcars.

(6) Assistance with transportability engineering and design for materiel to be transported in USAF aircraft and coordination with USAF ATTILA to obtain USAF air certification.

*b.* CAPDEVs and MATDEVs will coordinate with the Commander, NSRDEC (STRNC-UAS), Natick, MA 01760-5000 to obtain engineering and design assistance for certification of materiel to be airdropped from fixed-wing aircraft, internally or externally transported by tilt-rotor or rotary-wing aircraft, and for materiel that contains a rigid wall, nonstandard, or modified shelter.

### 2-3. Materiel capability documents

Tactical and strategic mobility requirements must be established early in the acquisition cycle and monitored throughout. The CAPDEVs in coordination with the MATDEVs and SDDCTEA will include a statement of the required modes of transport in the materiel capability documents.

*a.* For strategic transport, materiel will be transportable by highways, standard gauge railway, sea lift, and by USAF aircraft. Army aircraft will not be transported by railways.

*b.* For tactical transport, materiel transportability requirements (airlift, LVAD, high velocity airdrop, LOTS, and external or internal transport by rotary-wing aircraft) will be commensurate with the tactical deployability requirements of the units.

*c.* SEM with air transportability limited to the C-5 aircraft will be reserved only for those items that cannot be dimensionally and weight reduced within one hour to accommodate C-130 and C-17.

*d.* Except for equipment that does not carry its payload during transport (such as wreckers, dump trucks, and material handling equipment), cargo vehicles will be capable of being transported with rated payload by rail, water, and USAF aircraft.

*e.* When developing transportability requirement statements, include the following:

(1) *Highway.* If the item is to be transported or towed; the types and models of the planned transport vehicle will be stated and if unrestricted transport is required.

(2) *Rail*. State requirement for rail transportability in the continental United States and outside the continental United States. Include requirements for transport by specific types of rail equipment and any unrestricted requirements.

(3) *Sea lift*. State any specific ship transport and environmental or protective measures requirements.

(4) *Lighterages*. State and define the smallest lighter that is required to transport the item in LOTS operations.

(5) *Military cargo aircraft (fixed-wing)*. State the types required (C-27J, C-130, C-17, or C-5) and whether airdrop (LVAD or high velocity airdrop) is required. If sectionalization is permitted, state the permissible number of people and the assembly and disassembly clock hours.

(6) *Helicopters*. Specify the types of helicopters required (CH-46, CH-47, CH-53, UH-60, UH-72, or V-22) and whether internal and/or external airlift is required. Specify scenario and mission range.

(7) *Intermodal freight containers*. List the size (10, 20, 25, 30, 35, 40, or 45 feet) and the International Organization for Standardization (ISO) designation of containers in which transport is required. Normally, nonvehicular materiel and small vehicles will be containerized.

## **2-4. Transportability reports**

MATDEVs will submit a transportability report on all TPIs and systems with stated transportability requirements to Director, SDDCTEA (DPE), 1 Soldier Way, Scott AFB, IL 62225-5006.

a. MATDEVs shall submit transportability data to SDDCTEA. The data will be submitted in the transportability report as explained in appendix B.

b. Transportability reports and requests for transportability approval should be submitted to SDDCTEA based on each program's milestone decision review timeline.

c. An initial transportability report should be submitted to SDDCTEA as soon as the item's general configuration is established during the Materiel Solution Analysis Phase (pre-milestone A). Although physical information about the materiel may be limited, the initial report will provide SDDCTEA an early view of the proposed materiel. The initial transportability report will be submitted not later than 30 days before the milestone A decision review. SDDCTEA will then perform a transportability engineering assessment of the proposed item and provide results to the MATDEV within 30 days following receipt of the transportability report.

d. MATDEVs shall submit an updated transportability report and a request for transportability approval to SDDCTEA—

(1) No later than 60 days prior to the milestone B decision review. SDDCTEA will provide a transportability assessment within 45 days of the receipt of the updated transportability report, if requested by the MATDEV.

(2) No later than 60 days prior to milestone C decision review for NDIs or systems, the functional purchase description (or specification) must be submitted to SDDCTEA. A final transportability report based on the final design of the materiel (post critical design review) must be submitted no later than 60 days prior to awarding a production contract or the milestone C decision review, whichever occurs first.

e. SDDCTEA will formally grant transportability approval for RDT&E items, NDIs, or systems prior to milestone C if the item or system meets the transportability requirements established by the capability document. Appendix C contains a checklist of transportability actions.

f. The transportability report is required to support the material release of systems and equipment (see AR 700-142).

g. A transportability report should be submitted to SDDCTEA as soon as possible to start the transportability approval process for programs that do not follow or have not followed the standard acquisition timelines (for example, starting the process post-milestone B).

h. A new transportability report and request for a transportability approval update is required when modifications or upgrades increase shipping dimensions or weight of an item or system.

i. Transportability reports, SDDCTEA's transportability engineering assessments, and transportability approvals will be included in the life cycle sustainment plan.

## **2-5. Unit deployment analyses**

SDDCTEA and the CAPDEVs will review proposed materiel and determine the need for unit deployment assessments. Proposed materiel that have a strategic deployment requirement shall have a unit deployment assessment conducted by SDDCTEA during concept development. When a unit deployment assessment is required, a unit deployment analysis shall be conducted and furnished to the logistic representative before milestone B decision reviews. The analysis shall include the end item and all identified support equipment.

## **2-6. Airdrop and air transport**

Design assistance available from NSRDEC includes the following:

a. Analysis of proposed designs to determine Army rotary-wing and/or tilt-rotor air transport and airdrop acceptability. This assistance will be obtained as early as possible in the design stages of development.

b. Trial rigging procedures for air transport or airdrop of the final design for developmental materiel.

c. Laboratory facilities to conduct development tests in a controlled air transport and airdrop environment, including

lifting and tiedown provision restraint test facilities and static drop, roller, and extraction provision testing for materiel to be delivered by parachute.

*d.* Recommendations to provide optimum airdrop capability for component and system designs and energy dissipation configurations.

*e.* When equipment is developed for airdrop, auxiliary equipment such as platform, parachute, webbing strap, and energy dissipation material shall be considered (see MIL-HDBK-669). The unit (rigged) load will meet the limitations specified in MIL-HDBK-1791. Tiedown, suspension, and extraction provisions will meet the requirements of MIL-STD-814. Equipment designed for airdrop must also be designed to be air transportable in fixed-wing aircraft (see MIL-HDBK-1791).

*f.* Transportability approval by SDDCTEA is required for materiel that will be transported internally or externally by tilt-rotor or Army helicopters. MATDEVs will submit test data or structural analyses to SDDCTEA and NSRDEC that prove lifting and tiedown points meet MIL-STD-209 and MIL-STD-913. Test loadings or test flights may be required if the transportability engineering analysis indicates that transport criteria are not met or if flight characteristics of the item are unknown. Certification by the NSRDEC is required for transportability approval. Design assistance is available from USAF ATTLA for materiel with an internal fixed-wing air transport requirement (see MIL-HDBK-1791).

## **2-7. Transportability testing**

MATDEVs and CAPDEVs will use test facilities established and maintained by ATEC and TRADOC to conduct airdrop tests on materiel. This does not prevent the use of development agencies' static drop facilities that are already in existence and maintained for other developmental purposes. MATDEVs and CAPDEVs will not establish new test facilities to conduct airdrop tests on materiel.

*a.* When an air transportability test loading is required, the MATDEV will submit physical characteristics and lift and tiedown testing results, that were done in accordance with MIL-STD-209 to SDDCTEA or USAF ATTLA.

*b.* MATDEV will request a special assignment airlift mission or a test loading that complies with AR 59-9.

*c.* Transportability test procedures shall be coordinated with SDDCTEA at least 30 days before the test date. SDDCTEA shall be notified of the exact test time and location at least five days before the test. All transportability testing must be witnessed by SDDCTEA or SDDCTEA's appointed representatives.

## **2-8. Transportation Engineering Agency instructions**

SDDCTEA will provide detailed instructions for rail, highway, sea lift lifting and lashing, containerization, and air transport upon request that will aid in the transport of SEM. Contact SDDCTEA to obtain the information.

## **2-9. Transportability approvals**

MATDEVs shall provide transportability data, supporting pictures, and diagrams required for transportability approvals to Director, SDDCTEA (DPE), 1 Soldier Way, Scott AFB, IL 62225-5006. Include the following:

*a.* Item preparation, loading, securing, and unloading procedures for shipment of the item by all appropriate modes of transportation will be specified.

*b.* Transportability pictures and/or diagrams, to include transportability clearance diagrams of end and side profile drawings, that include critical dimensions, weight, and other technical data.

*c.* Transportability characteristics data within 30 days of an item being assigned either—

(1) To a table of organization and equipment.

(2) A standard line item number.

*d.* When SDDCTEA receives the required transportability certifications (shelter, air transport, helicopter sling loading, and/or airdrop) for an item, within 45 days of receipt of the final test report from the testing organization, SDDCTEA will provide the transportability approval in support of materiel release and type classification (see AR 700-142). Transportability approvals will be based on the final test reports, not draft test reports. Test reports will typically be for MIL-STD-209 lifting and tiedown testing and MIL-STD-810 rail impact testing.

*e.* When SDDCTEA has conducted a transportability engineering analysis and granted transportability approval for an item, the MATDEV will either—

(1) Certify that the data submitted during RDT&E are valid for the production model.

(2) Submit corrected data on the standard line item number.

## **Appendix A References**

### **Section I Required Publications**

Military handbooks and military standards are available at <https://assist.dla.mil/quicksearch/>.

#### **AR 59-9**

Special Assignment Airlift Mission Requirements (Cited in para 2-7.)

#### **AR 70-1**

Army Acquisition Policy (Cited in paras 1-12, 1-13, and 1-18.)

#### **AR 71-9**

Warfighting Capabilities Determination (Cited in para 1-13.)

#### **AR 700-15/NAVSUPINST 4030.28E/AFJMAN 24-206/MCO 4030.33E/DLAR 4145.7**

Packaging of Materiel (Cited in para 1-18.)

#### **AR 700-127**

Integrated Logistic Support (Cited in para 1-18.)

#### **AR 700-142**

Type Classification, Materiel Release, Fielding, and Transfer (Cited in paras 1-13, 2-4, and 2-9.)

#### **MIL-HDBK-669**

Loading Environment and Related Requirements for Platform Rigged Airdrop Materiel (Cited in paras 2-1, 2-6, and D-4.)

#### **MIL-HDBK-1791**

Designing for Internal Aerial Delivery in Fixed Wing Aircraft (Cited in paras 2-1, 2-6.)

#### **MIL-STD-209**

Lifting and Tiedown Provisions (Cited in paras 1-18, 2-1, 2-6, 2-7, 2-9, B-4, and D-4.)

#### **MIL-STD-810**

Environmental Engineering Considerations and Laboratory Tests (Cited in paras 1-18, 2-9, and D-4.)

#### **MIL-STD-814**

Requirements for Tiedown, Suspension and Extraction Provisions on Military Materiel for Airdrop (Cited in paras 2-1, 2-6, and D-4.)

#### **MIL-STD-913**

Requirements for the Certification of Sling Loaded Military Equipment for External Transportation by Department of Defense Helicopters (Cited in paras 2-6, D-4.)

#### **MIL-STD-1366**

Transportability Criteria (Cited in paras 2-1, B-4.)

#### **TB 700-2/NAVSEAINST 8020.8B/TO 11A-1-47/DLAR 8220.1**

Department of Defense Ammunition and Explosives Hazard Classification Procedures (Cited in para 1-18.) (Available at <https://www.logsa.army.mil/>)

### **Section II**

#### **Related Publications**

A related publication is a source of additional information. The user does not have to read a related publication to understand this publication.

#### **AFR 71-4/TM 38-250/NAVSUP PUB 505 (REV)/MCO P4030.19D/DSAM**

Preparing Hazardous Materials for Military Air Shipments (Available at <http://www.e-publishing.af.mil/>)

**DODD 4510.11**

DOD Transportation Engineering (Available at <http://www.dtic.mil/whs/directives/>.)

**DODD 5000.01**

The Defense Acquisition System (Available at <http://www.dtic.mil/whs/directives/>.)

**DODI 4540.07**

Operations of the DOD Engineering for Transportability and Deployability Program (Available at <http://www.dtic.mil/whs/directives/>.)

**DODI 5000.02**

Operation of the Defense Acquisition System (Available at <http://www.dtic.mil/whs/directives/>.)

**TB 55-46-1**

Standard Characteristics (Dimensions, Weight, and Cube) for Transportability of Military Vehicles and Other Outsize/Overweight Equipment (in table of organization and equipment line item number sequence)

**TB 55-46-2**

Standard Characteristics (Dimensions, Weight, and Cube) for Transportability of Military Vehicles and Equipment {NAVFAC P-1057}

**49 CFR, Parts 105-180**

HAZMAT Transportation

**49 USC**

Transportation (Available at <http://www.gpoaccess.gov/uscode/>.)

**Section III****Prescribed Forms**

This section contains no entries.

**Section IV****Referenced Forms**

Unless otherwise indicated below, DA Forms are available on the Army Publishing Directorate Web site (<http://www.apd.army.mil>).

**DA Form 11-2**

Internal Control Evaluation Certification

**DA Form 2028**

Recommended Changes to Publications and Blank Forms

**Appendix B****Format For Transportability Report****B-1. Purpose**

The transportability report is a document listing all of the characteristic data information for a TPI. The transportability report provides all information necessary to perform a comprehensive transportability engineering analysis of TPIs. The transportability report will be used to obtain essential information from MATDEVs for evaluating the transportation limitations and restrictions of DOD equipment that qualifies as a TPI. Information acquired through this report will include dimensional and weight characteristics of the item or system; test results of physical transportability testing performed on the equipment; and when available, computer aided design (CAD) models of the equipment to support structural, kinematic, and dynamic analyses of the transportation environment and results of any CAD structural, kinematic, or dynamic analyses performed by the contractor.

**B-2. Special provisions**

If an Army vehicle must be transported inside a USAF aircraft, the physical characteristics of the equipment and/or vehicle (including three-view outer dimensional details of the equipment and/or vehicle), proposed tiedown pattern, and

the proposed on and/or off load plan must be submitted to SDDCTEA or the USAF ATTLA at the address provided in paragraph B-3.

### **B-3. Responsibility**

Transportability reports and physical characteristics are prepared by MATDEVs (CAPDEVs when applicable) and are submitted to Director, SDDCTEA (DPE), 1 Soldier Way, Scott AFB, IL 62225-5006 and ASC/ENFC (ATTLA), 2145 Monahan Way, Wright Patterson AFB, OH 45433-7017.

### **B-4. Report format**

Be sure to list the reference documents. The applicable issue of documents cited herein, including their approval dates and dates of any applicable amendments, notices, and revisions, shall be cited in the current issue of the DOD Index of Specifications and Standards at the time of the solicitation. The information required for the transportability report and the format follows:

- a. Title. (Transportability report).
- b. State contractor name, location, phone number, and e-mail address. State the name, title, organization, and department of individual preparing the transportability report.
- c. Date of transportability report.
- d. Official nomenclature.
- e. National stock number (if known).
- f. Line item number (if known).
- g. Brief description.
  - (1) List the transportability requirements from the requirements document and provide the source for the requirements (for example, list the capabilities production document).
  - (2) State the intended use of the item.
  - (3) List whether the item is commercial, modified commercial, nondevelopmental, developmental, reprocurement, or modified equipment.
  - (4) Specify type of military units that will use or transport the item.
  - (5) State whether the item is for worldwide use or for a specific theater of operations.
  - (6) Planned quantity of the item. State item acquisition quantity by fiscal year.
  - (7) State if any special equipment (such as, railcars or trailers) or material handling equipment will be required to move and/or transport the item.
- h. Transportability requirements.
  - (1) Documents.
    - (a) Send copy of justification for major system new start, required operational capacity, letter requirement, letter of agreement, capabilities production document, capability development document, specification, or other requirements documents.
    - (b) Send copy of system specification.
  - (2) Highway.
    - (a) State if item is self-propelled, towed, or transported by truck or semitrailer.
    - (b) Give model numbers of required transporter(s) (for example, M1088/M872 or M915/M871).
  - (3) Rail.
    - (a) State if item will require rail transport in the continental United States and/or oversea areas.
    - (b) State foreign country where rail transport is required.
  - (4) Ocean and waterways.
    - (a) State if item will be shipped overseas in volume (unit) movements.
    - (b) State if on-deck storage is permissible.
    - (c) State type(s) of ship(s) (that is, breakbulk, container, roll-on/roll-off) required.
  - (5) *Lighterage*. State if item is used in the LOTS environment.
  - (6) *Intermodal containers*. List the size (that is, 20, 40, or 45 feet) or the American National Standards Institute or ISO designation of containers in which transport is required.
  - (7) Helicopters.
    - (a) Specify the model number(s) of cargo helicopter(s) required.
    - (b) State if internal and/or external airlift is required. (Current Army utility/cargo helicopters are the UH-60 and CH-47.) (Current Marine Corps helicopters are CH-46 and CH-53.)
    - (c) Give the helicopter mission requirements (time and distance of mission, atmospheric condition requirements, such as, 95 fahrenheit, 4000 feet, and 59 fahrenheit at sea level).
  - (8) *Fixed wing aircraft*. State the type(s) of aircraft transport required. (Current USAF aircraft are C-130, C-17, and C-5.) (Current Civil Reserve Air Fleet are B-707, B-747, DC-8, and MD-11.)

i. Transportation data.

(1) *Hazardous materiels*. For each item classified as hazardous material, state—

(a) The class of hazardous material as specified in Title 49, Code of Federal Regulations, Parts 105–180; AFMAN 24–204; International Civil Aviation Reorganization, Technical Instructions for the Safe Transport of Dangerous Good by Air; International Maritime Organization, International Maritime Dangerous Good Code; or the United Nation’s Recommendation on the Transportation of Dangerous Goods.

(b) Department of Transportation proper shipping name.

(c) Net explosive weight (Department of Transportation class 1, division 1.1, 1.2, or 1.3 explosives only).

(d) Venting requirements.

(e) Grounding requirements.

(2) *Sectionalization and reduction*. State if the item can be sectionalized, folded, or reduced for transport and provide the following information:

(a) Time and personnel required to disassemble at port of embarkation and reassemble at port of debarkation (time: in work and clock hours).

(b) Special equipment, tools, or software required for sectionalization or reduction (for example, cranes, forklifts, wrecker trucks, pallets, nitrogen, hand tools, calibration equipment, fixtures, or height management system software).

(c) All of the data that is required for the transportability report for the operational equipment must also be provided for each component(s) or subassembly that exceeds the criteria for a TPI (see MIL–STD–1366). For each component(s) or subassembly not exceeding the criteria for a TPI, provide only the length, width, height, and weight of each sectionalized component.

(3) *Modeling and simulation (when available)*. Provide engineering drawings or CAD models of the equipment to support structural, kinematic, and dynamic analyses of the transportation environment or provide results of CAD transportation analyses performed by the contractor. Dimensions for length, width, height, and location of center of gravity in all 3 directions are required (see fig B–1).

(4) *Transportability tests*. A copy of test report(s) (or test plan and scheduled date(s) if not completed) shall be included as a part of this report, when available.

(5) *Speed requirements*. State self-propelled or towed speed limits.

(6) *Shipping data plate*. A paper copy of the shipping data plate that will be secured to the vehicle shall be included with this report, when available (see MIL–STD–209).

(7) *Crew size*. State number of Soldiers required for a crew. Crew weights for up to a five Soldier crew can be found in table B–1.

**Table B–1  
Crew weights from MIL–STD–1366**

Total crew weight	Without body armor (pound, kilogram)	With body armor <sup>1</sup> (pound, kilogram)
Single Solider crew	334, 151.5	363, 164.7
Two Solider crew	640, 290.3	698, 313.6
Three Solider crew	936, 424.6	1023, 464.0
Four Solider crew	1,220, 553.4	1,336, 606.0
Five Solider crew	1,504, 682.2	1679 <sup>2</sup> , 761.6

1. For a single through four Soldier crew, 29 pounds of body armor is added for each Soldier.

2. For a five Soldier crew, 116 pounds (4 x 29) is added for crew members’ armor, plus 59 pounds is added for the gunner’s armor (Cupola Protection Ensemble).

(8) *Photographs*. Provide electronic or hardcopy photographs of equipment.

(9) *Dimensional and weight data tables*. The data in the tables shall be provided for all configurations of the equipment. As a minimum, one data table shall be provided for the fully operational configuration (including gross weight, fuel, lubricants, water, crew, and basic issue item equipment) and one data table shall be provided for the shipping (reduced or sectionalized) configuration. If there are different reduced shipping configurations for various transportation assets and modes, a different data table shall be provided for each different shipping configuration.

(a) *Weight*. State curb weight and maximum gross weight and any other intermediate weights for special configurations required to meet specific transport requirements (that is, fixed-wing air transport or helicopter transport).

(b) *Drawings (required if computer aided design models are not provided (see para B–4i(3))*. Indicate top, plane,

side, and end view configurations on each drawing. Hardcopy or electronic files are acceptable. Drawings must include all data as shown in figures B-1, B-2, or B-3.

(10) *Lift and tiedown provisions (see MIL-STD-209).*

(a) State the number, location, and strength (yield and ultimate) of lift (including aerial recovery), equipment tiedown, multipurpose, cargo tiedown, and supplemental air transport tiedown provisions for the item and major components removed for transport.

(b) Provide the dimensional location of the lift, equipment tiedown, multipurpose, and supplemental air transport provisions (with respect to the center of gravity) as shown in figure B-4.

(c) Provide the dimensional location of the cargo tiedown provisions with respect to the center of the cargo area, as shown in figure B-5.

(d) Provide the dimensions A, B, D, E, CL, and CS for each lift, equipment tiedown, multipurpose, and higher strength cargo tiedown provisions, as shown in figure B-6.

(e) Provide the dimensions A and B for the cargo tiedown provisions, as shown in figure B-7.

(f) Provide the opening size of the supplemental air transport tiedown provisions.

(g) Identify the location of hardpoint lift provisions provided for aerial recovery (if required).

(11) *Projections.* State the dimensions and locations of any significant projections (for example, environmental control units, ladders, protruding tiedown provisions, antennas, and shelters). See figures B-1, B-2, and B-3.

(12) Additional information required for wheeled vehicles.

(a) *Weight ratings.* Specify the gross vehicle weight rating.

(b) *Tires.* State the number, size(s), load rating(s), locations, and inflation pressure of tires.

(c) *Axle loads.* State the axle load for each axle for the following configurations:

1. Vehicle at curb weight.
2. Vehicle at maximum gross weight. (For cargo vehicles, assume a uniform load on the cargo bed.)
3. Intermediate weights for special configurations required to meet specific transport requirements (that is, fixed-wing air transport or helicopter transport).

(d) *Maximum axle load ratings.*

1. State maximum axle loads for each axle.

2. State the tracking width of each axle (see fig B-10).

(e) *Kingpin and/or lunette and fifth wheel/pintle rating and loads, as applicable.*

1. State the kingpin/lunette and fifth wheel/pintle ratings and actual loads.

2. State distance between first axle and kingpin/lunette and height of kingpin/lunette.

3. State distance between last axle and fifth wheel/pintle and height of fifth wheel/pintle.

4. For trailers, state the required prime movers. For truck-tractors, state the trailer to be towed.

(f) *Landing legs, as applicable.*

1. State rating for landing legs.

2. State axle loads and landing leg load, when trailer is resting on landing legs. State distance between landing and kingpin/lunette.

3. Provide dimensions of landing legs as shown in figure B-8.

(g) *Suspensions type and ratings.* State type and load ratings for each suspension.

(h) *Crest angle.* State the angle (in degrees) connecting two horizontal surfaces that the vehicle can pass (crest) without interference (see fig B-9).

(i) *Tire footprint area.* State the locations and dimensions of all tire footprint areas actually in contact with the ground in the fully loaded condition (see fig B-10).

(j) *Axle tracking width.* State the tracking width of each axle (see fig B-11).

(k) *Vehicle turning diameter.* State the vehicle turning diameter for the following:

1. Wall-to-wall.

2. Curb-to-curb.

(13) Additional information required for tracked vehicles.

(a) *Road wheels.* State number of road wheels and road wheel axle spacing.

(b) *Track pads.* State the areas and number of track shoe pads actually in contact with the ground (see fig B-12).

(c) *Ground pressure.* Specify the ground pressure created by the heaviest pad (pounds per square inch). State the weight support by each road wheel.

(14) Additional information required for skid-mounted equipments.

(a) Number of skids.

(b) Dimensions of all skid areas actually in contact with the ground.

(c) Specify ground pressure created by each skid (pounds per square inch).



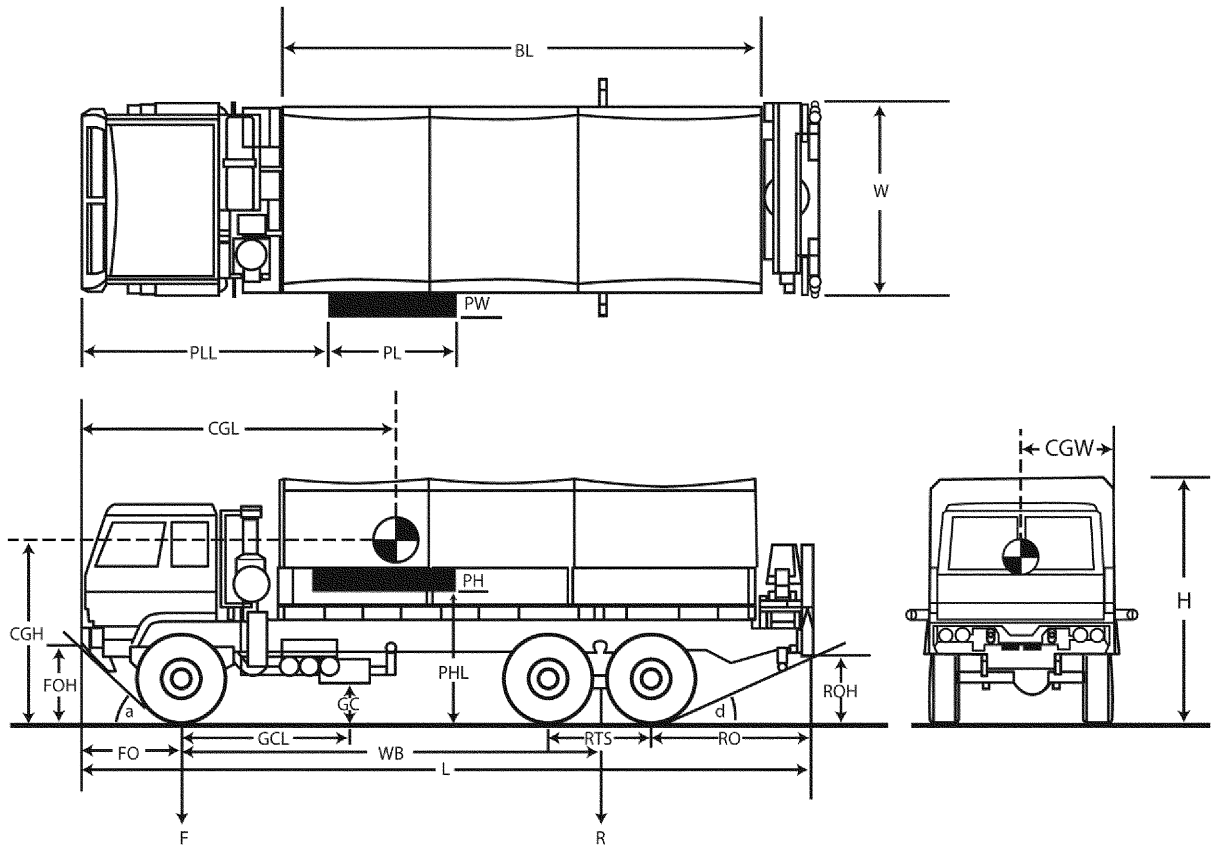

**LEGEND**

- |                                |                                  |
|--------------------------------|----------------------------------|
| H - overall height             | PW - projection width            |
| W - overall width              | PH - projection height           |
| L - overall length             | PL - projection length           |
| F - front axle load            | BL - body length                 |
| R - rear axle load             | PHL - projection height location |
| CGL - center of gravity length | PLL - projection length location |
| CGW - center of gravity width  | WB - wheel base                  |
| CGH - center of gravity height | RTS - rear tire separation       |
| FO - front overhang            | GC - ground clearance            |
| RO - rear overhang             | GCL - ground clearance location  |
| FOH - front overhang height    | a - angle of approach            |
| ROH - rear overhang height     | d - angle of departure           |

**Figure B-1. Wheeled vehicle dimensions**

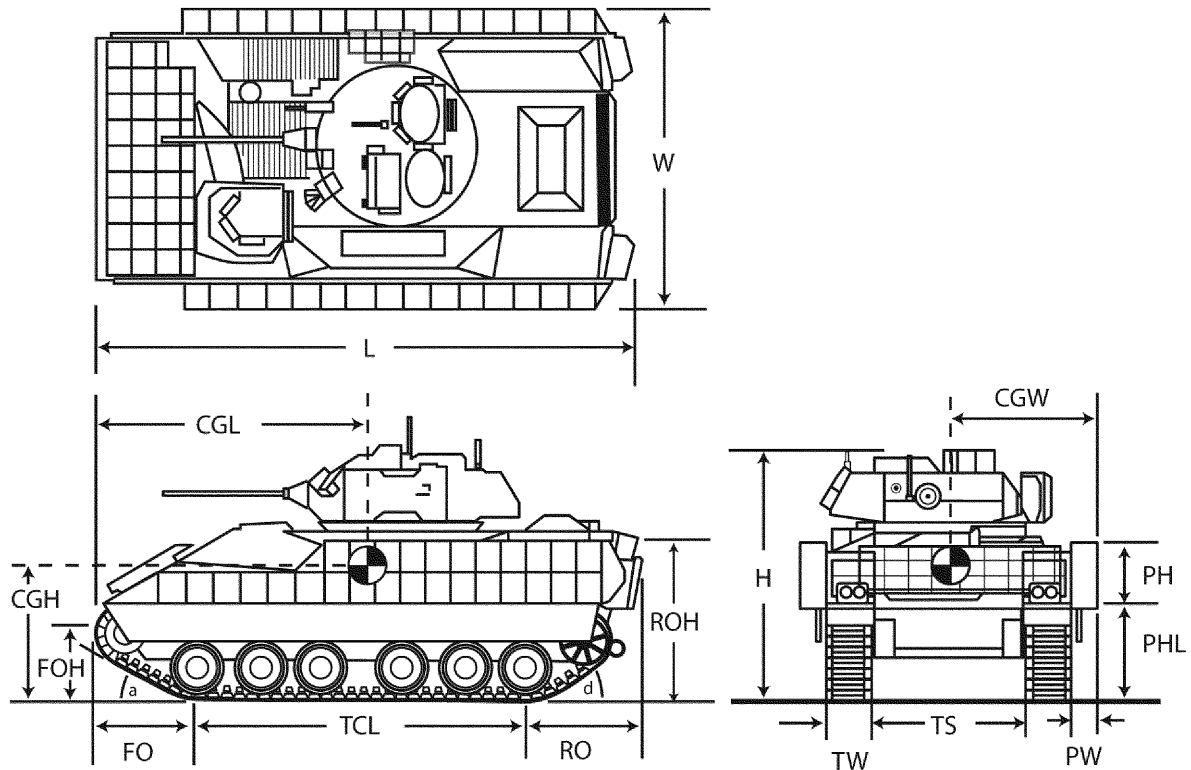

**LEGEND**

- |                                |                                  |
|--------------------------------|----------------------------------|
| H - overall height             | FOH - front overhang height      |
| W - overall width              | ROH - rear overhang height       |
| L - overall length             | TW - track width                 |
| CGL - center of gravity length | PH - projection height           |
| CGW - center of gravity width  | PW - projection width            |
| CGH - center of gravity height | PHL - projection height location |
| TCL - track center line        | TS - track separation            |
| FO - front overhang            | a - angle of approach            |
| RO - rear overhang             | d - angle of departure           |

**Figure B-2. Tracked vehicle dimensions**

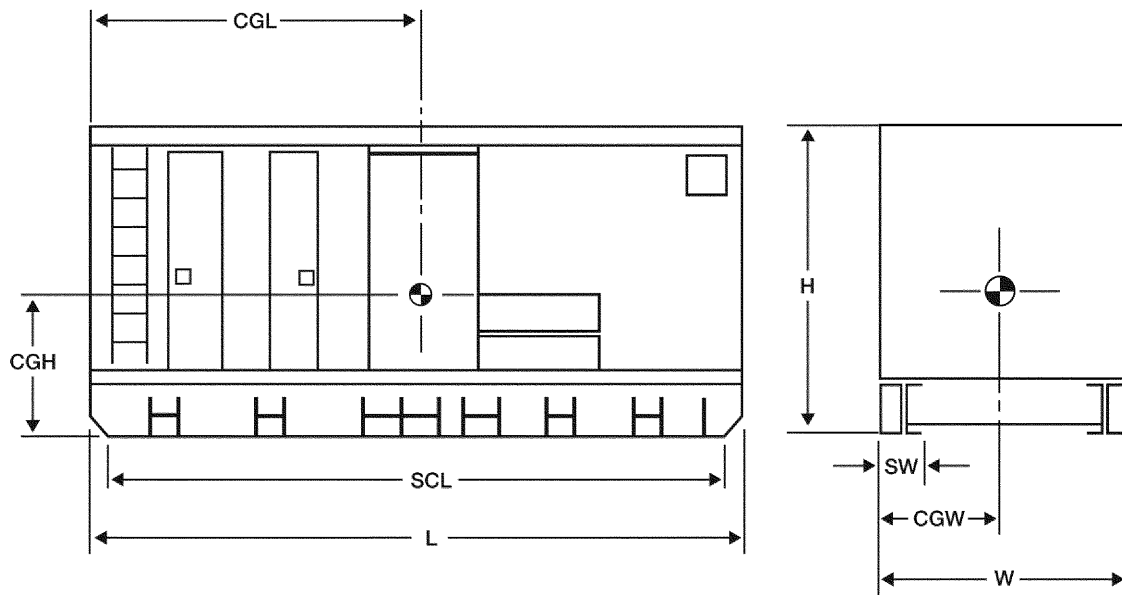

**LEGEND**

- |                           |                                |
|---------------------------|--------------------------------|
| SCL - skid chamber length | H - overall height             |
| SW - skid width           | CGL - center of gravity length |
| L - overall length        | CGW - center of gravity width  |
| W - overall width         | CGH - center of gravity height |

Figure B-3. Skid-mounted item dimensions

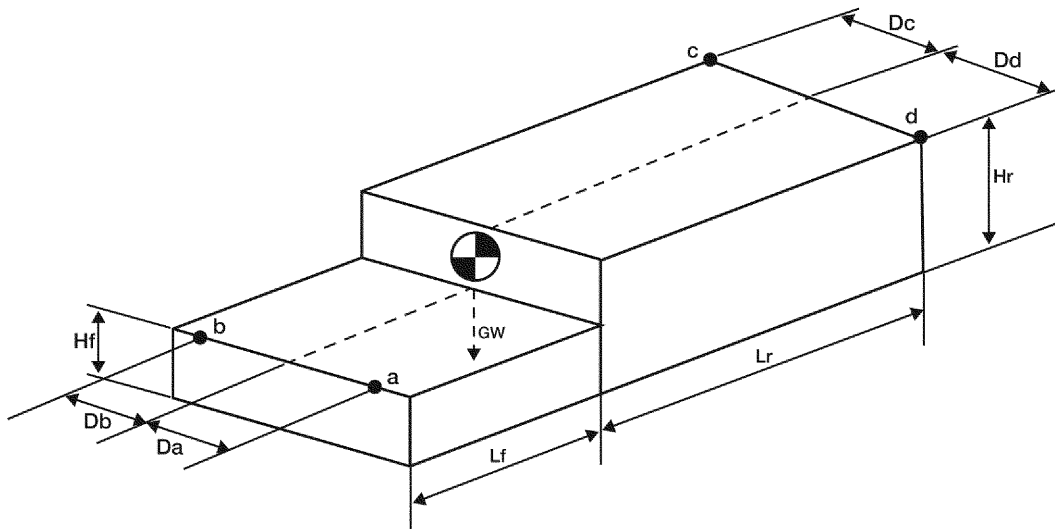

**LEGEND**

- Da - lateral distance from provision a to the center of gravity
- Db - lateral distance from provision b to the center of gravity
- Dc - lateral distance from provision c to the center of gravity
- Dd - lateral distance from provision d to the center of gravity
- Hf - height of front provisions
- Hr - height of rear provisions
- Lf - longitudinal distance between front provisions
- Lr - longitudinal distance between the rear provisions and the center of gravity
- GW - gross weight

Figure B-4. Dimensions defining the location of the lift and tiedown provisions

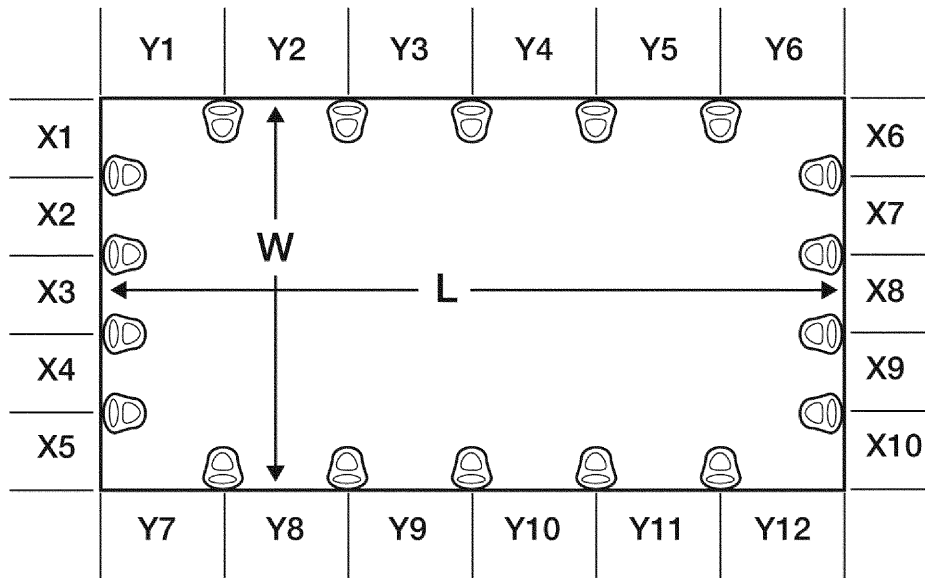

**LEGEND**

- X1- X10 - distance between provisions on front and rear of cargo bed
- Y1- Y12 - distance between provisions on left and right side of cargo bed
- W - width of cargo bed
- L - length of cargo bed

Figure B-5. Dimensions to determine location of cargo tiedown provisions

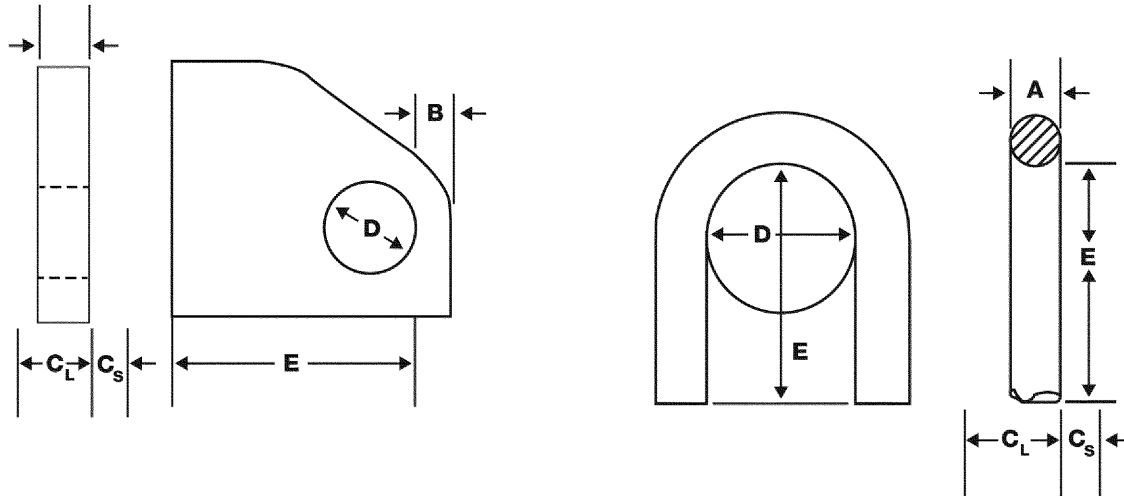

**LEGEND**

$C_L$  and  $C_S$  are the dimensions between one side of the provision and the nearest interference or obstruction. Either side of the provision may be used as the datum from which to measure  $C_L$  and  $C_S$ .  $E$  is the dimension between the outer edge of  $D$  and the nearest interference or obstruction.

Figure B-6. Lift and tiedown provision dimensions

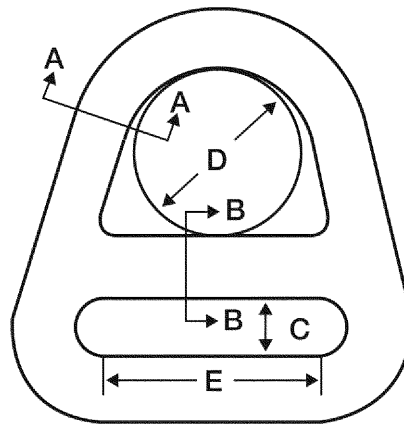
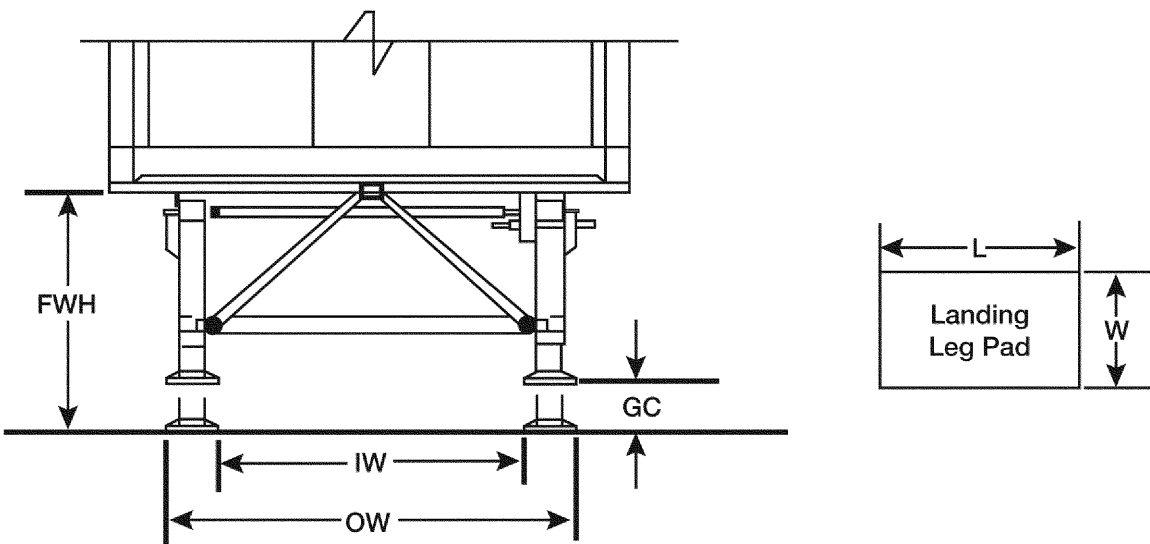

Figure B-7. Cargo tiedown dimensions



**LEGEND**

- |                               |                              |
|-------------------------------|------------------------------|
| FHW - fifth wheel height      | GC - ground clearance        |
| IW - inside width             | OW - outside width           |
| L - length of landing leg pad | W - width of landing leg pad |

Figure B-8. Landing leg dimensions

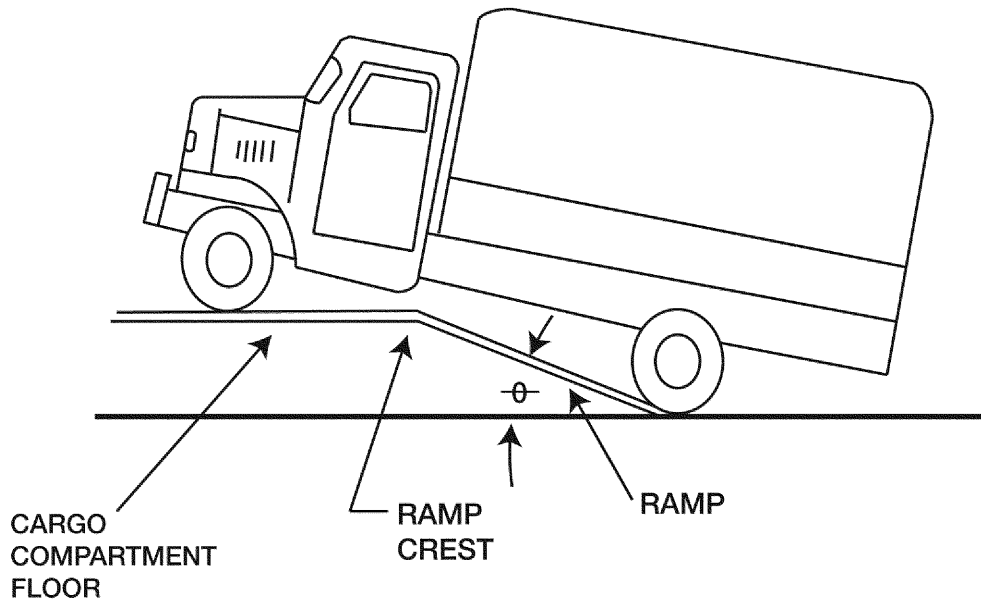
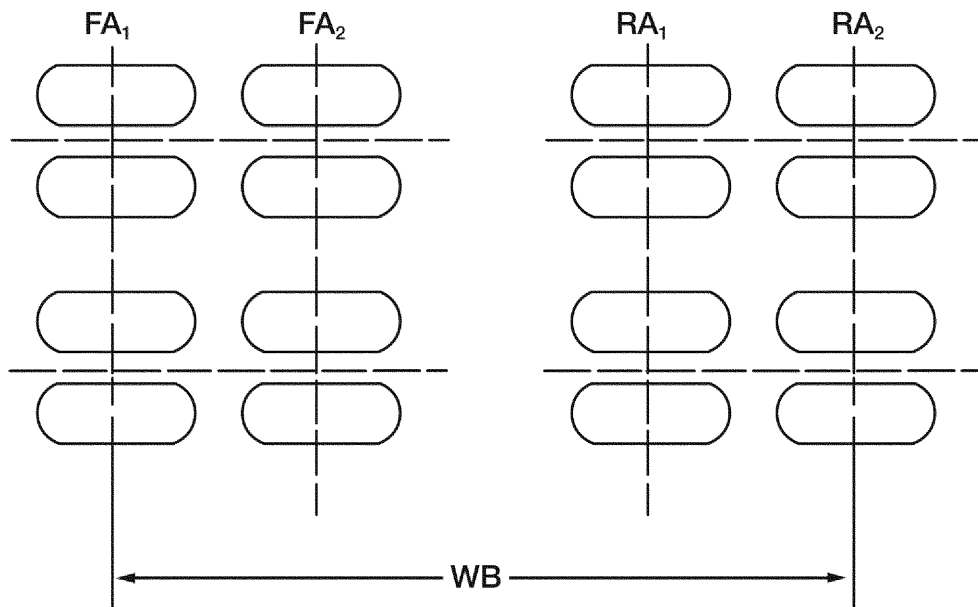

Figure B-9. Ramp crest angle



**LEGEND**

FA - front axle (1 or 2), RA - rear axle (1 or 2), and WB - wheel base. Dimensions are needed for the tire footprint (contact area) and the distance between the axles (wheel base).

Figure B-10. Tire footprint area and wheel base dimension

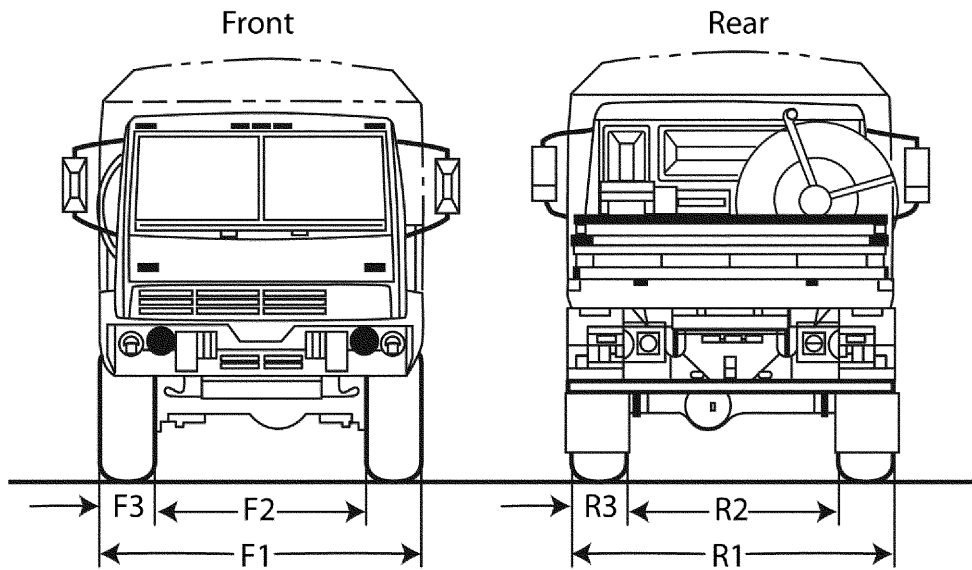

**LEGEND**

F1 - outside distance  
 F2 - inside distance  
 F3 - tire width

R1 - outside width  
 R2 - inside distance  
 R3 - rear tire width

Figure B-11. Axle tracking width



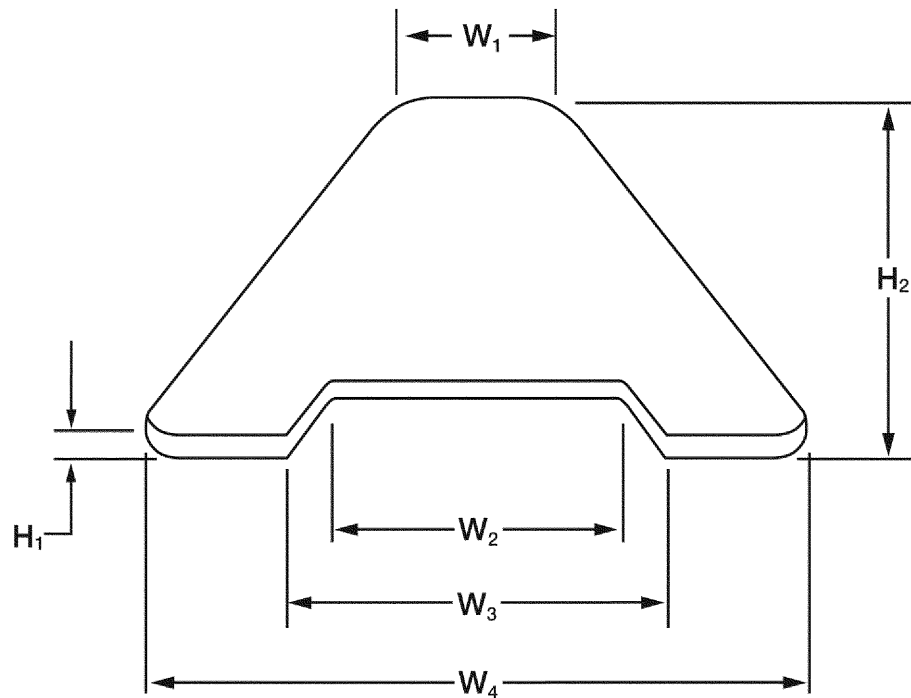

**LEGEND**

H - height  
W - width

Figure B-12. Track shoe pad dimensions (footprint data)

**Appendix C  
Checklist of Transportability Actions**

**C-1. Transportability actions**

A checklist of transportability actions is at table C-1.

**Table C-1  
Checklist of transportability actions**

Item	Action	Responsibility
1.	Assess the materiel and determine whether it is an NPI or TPI.	SDDCTEA
2.	Determine the required interface of the system with the anticipated transportation system.	CAPDEV
3.	Assess design risk in transportability in the letter of agreement; include a milestone for transportability approval.	MATDEV
4.	Identify all TPIs in the transportability report.	MATDEV
5.	List essential transportability requirements in the capability development document and/or capability production document.	CAPDEV
6.	Submit initial transportability report to SDDCTEA prior to milestone A (where applicable based on the program milestone review timeline).	MATDEV or CAPDEV
7.	Submit tentative basis of issue plan data for selected systems to SDDCTEA for unit deployability assessment.	CAPDEV
8.	Include results of SDDCTEA's initial transportability assessment in milestone A report.	MATDEV
9.	Coordinate TEMP with SDDCTEA.	MATDEV

**Table C-1**  
**Checklist of transportability actions—Continued**

10.	Request a transportability assessment from SDDCTEA prior to milestone B (where applicable based on the program milestone review timeline).	MATDEV
11.	Identify transportability requirements in the contract statement of work.	MATDEV
12.	Submit information required for air transport, helicopter sling load, shelter, and LVAD certifications, if required.	MATDEV
13.	Submit final test reports and independent evaluations to SDDCTEA prior to milestone C (where applicable based on the program milestone review timeline).	MATDEV
14.	Request transportability approval from SDDCTEA prior to milestone C (where applicable based on the program milestone review timeline).	MATDEV
15.	Submit end-item transportability characteristic to SDDCTEA for DA master file for table of organization and equipment (see TB 55-46-1 and TB 55-46-2).	MATDEV
16.	Submit data to SDDCTEA for supplemental review of materiel modifications and upgrades that alter item configuration.	MATDEV

## C-2. Comments

Help make table C-1 a better review tool. Submit comments to Deputy Assistant Secretary of the Army (Acquisition Policy and Logistics) (SAAL-ZL), 103 Army Pentagon, Washington, DC 20310-0103.

## Appendix D

### Internal Control Evaluation

#### D-1. Function

The function covered by this checklist is the conduct of the Engineering for Transportability Program by MATDEVs and other functional specialists supporting the Engineering for Transportability Program.

#### D-2. Purpose

The purpose of this checklist is to assist MATDEVs to evaluate the application of transportability engineering principles during the materiel acquisition and design process.

#### D-3. Instructions

Answers must be based upon the actual testing of controls (for example, document analysis, direct observation, sampling, simulation, and/or others). Answers that indicate deficiencies must be explained and the corrective action indicated in the supporting documentation. These internal controls must be evaluated at least once every 5 years and then certified on DA Form 11-2 (Internal Control Evaluation Certification).

#### D-4. Test questions

- a. Establish internal procedures and controls to implement the Engineering for Transportability Program.
  - (1) Are MATDEV transportability engineering focal points assigned?
  - (2) Are transportability requirements considered in all phases of materiel development and identified in the life cycle sustainment plan and TEMP?
  - (3) Have all TPIs been identified?
  - (4) Have all NPIs been identified?
  - (5) Is a plan in place to conduct IPRs with appropriate stakeholders?
  - (6) Is a process in place to monitor TPIs until deficiencies are corrected and a transportability approval is obtained?
- b. Testing—
  - (1) Were transportability test requirements coordinated with the CAPDEV, operational tester, Army logistician, and SDDCTEA and included in the TEMP?
  - (2) Airdrop—
    - (a) Are test facilities established and maintained by U.S. Army Test and Evaluation Command and TRADOC and used to conduct airdrop tests on materiel?
    - (b) Were MIL-HDBK-669, MIL-STD-209, and MIL-STD-814 tests completed and vehicle data sheets submitted to SDDCTEA, NSRDEC, and USAF ATTILA to support air transportability test loading and airdrop?
    - (3) Were developmental tests of new and modified or updated materiel conducted to identify deficiencies and ensure compliance with transportability requirements?

(4) Were test data and structural analyses submitted to SDDCTEA and NSRDEC that prove lifting and tiedown points comply with MIL-STD-209 and MIL-STD-913 for materiel to be transported internally or externally by Army helicopters?

(5) Did rail impact tests comply with MIL-STD-810?

(6) If a shelter is involved, was NSRDEC consulted to review the need for a shelter certification?

c. Coordination—

(1) Has the request been made that SDDCTEA assign a transportability engineer to support the MATDEV?

(2) Was SDDCTEA notified of changes in materiel dimensions or weight resulting from product improvements, modifications, and upgrades?

(3) Was logistics management information related to transportability and transportation provided to SDDCTEA for update to the DA master file of standard equipment characteristics?

(4) Was NSRDEC contacted to obtain engineering and design assistance for certification of materiel to be air-dropped from fixed-wing aircraft or internally or externally transported by U.S. Army rotary-wing aircraft or for any required shelter certifications?

d. Transportability report—

(1) Was all transportability data submitted in the transportability report format prescribed in appendix B?

(2) Was an initial transportability report submitted to SDDCTEA no later than 30 days before the milestone A decision review?

(3) Was an updated transportability report submitted to SDDCTEA:

(a) No later than 60 days prior to the milestone B decision review for RDT&E materiel?

(b) No later than 60 days prior to the milestone C decision review for NDI (and functional purchase description (or specification) submitted 60 days prior to the milestone C decision review)?

(c) No later than 60 days prior to awarding a production contract?

(4) Was a request for transportability analysis and approval submitted to SDDCTEA?

#### **D-5. Supersession**

Not applicable.

#### **D-6. Comments**

Help make this a better review tool. Submit comments to Deputy Assistant Secretary of the Army (Acquisition Policy and Logistics) (SAAL-ZL), 103 Army Pentagon, Washington, DC 20310-0103.

## **Glossary**

### **Section I Abbreviations**

**AFB**

Air Force Base

**AMC**

U.S. Army Materiel Command

**ASA (ALT)**

Assistant Secretary of the Army (Acquisition, Logistics and Technology)

**ASA (IE&E)**

Assistant Secretary of the Army (Installations, Energy and Environment)

**ATEC**

U.S. Army Test and Evaluation Command

**CAD**

computer aided design

**CAR**

Chief, Army Reserve

**CAPDEV**

capability developer

**CG**

Commanding General

**CNGB**

Chief, National Guard Bureau

**DA**

Department of the Army

**DCS, G-3/5/7**

Deputy Chief of Staff, G-3/5/7

**DCS, G-4**

Deputy Chief of Staff, G-4

**DID**

data item description

**DOD**

Department of Defense

**IPR**

in-process review

**LOTS**

logistics-over-the-shore

**MATDEV**

materiel developer

**MIL-HDBK**

military handbook

**MIL-STD**

military standard

**NDI**

nondevelopmental item

**NPI**

nonproblem item

**NSRDEC**

U.S. Army Natick Soldier, Research, Development and Engineering Center

**RDT&E**

research, development, test, and evaluation

**SDDC**

Military Surface Deployment and Distribution Command

**SDDCTEA**

Military Surface Deployment and Distribution Command Transportation Engineering Agency

**TB**

technical bulletin

**TBOIP**

temporary basis of issue plan

**TEMP**

test and evaluation master plan

**TPI**

transportability problem item

**TRADOC**

U.S. Army Training and Doctrine Command

**USAF**

U.S. Air Force

**Section II****Terms****Airdrop certification**

Airdrop certification is an official statement issued by the NSRDEC that an SEM item may be airdropped from fixed-wing aircraft.

**Airlift certification**

Airlift certification is an official statement by USAF ATTILA that an item of SEM is transportable in USAF Air Mobility Command prime mission cargo aircraft and Civil Reserve Aircraft Fleet aircraft. Items less than 96 inches in width by 240 inches in length by 96 inches in height, and less than 10,000 pounds in weight do not require special procedures, do not operate in flight, and/or can be loaded and/or transported using standard methods in accordance with the aircraft cargo loading manual are not included in the certification process. For more detailed criteria, refer to MIL-HDBK-1791.

**Fragile item**

An item of SEM that is susceptible to damage and loss of serviceability during transport and handling and requires special shipping procedures or equipment, environmental control, or special packaging for protection during transport.

**Hazardous material**

A substance or material that has been determined and designated by the Secretary of Transportation and/or the Services to be capable of posing an unreasonable risk to health, safety, and property when transported. Included are explosives,

articles such as flammable liquids and solids, and other dangerous oxidizing materials, corrosive materials, compressed gasses, poisons and irritating materials, etiologic agents, and radioactive materials. (See 49 USC and AFR 71-4/TM 38-250/NAVSUP PUB 505 (REV)/MCO P4030.19D/DSAM 4145.3.)

### **Helicopter certification**

Helicopter certification is an official statement issued by the NSRDEC that an item of SEM is internally and/or externally transportable by Army rotary-winged aircraft.

### **Lighter**

Craft used to transport cargo or personnel from ship to shore; may include amphibians, landing craft, causeways, ferries, and barges.

### **Lighterage**

The process in which small craft are used to transport cargo or personnel from ship to shore. Lighterage may be performed using amphibians, landing craft, discharge lighters, causeways, and barges.

### **Systems/equipment/munitions materiel**

All items and item components necessary for the equipment, maintenance, operation, and support of military activities without distinction as to their application for administrative or combat purposes, excluding ships.

### **Transportability**

The inherent capability of an item or system to be effectively and efficiently moved by required transportation assets and modes.

### **Transportability approval**

A statement from SDDCTEA, the Army transportability agent, that an item of materiel, in its shipping configurations, is transportable by the required mode(s) of transportation and meets its transportability requirements.

### **Transportability assessment**

Initial assessment of an item's ability to meet deployment requirements. The evaluation is based on the item's projected dimensions, operational capabilities, and fielding requirements.

### **Transportability characteristics data**

Basic transportability data on all items of the table of organization and equipment are maintained in the DA standard transportability data file. It includes dimensions and weight of each item of materiel in the various shipping configurations together with the item nomenclature and identification (line item number and national stock number) and information on item characteristics that influence transporting the item (for example, location and strength of tiedown and lifting provisions, location of center of gravity, wheel and track loads and pressure, and cargo bed dimensions).

### **Transportability criteria**

The physical characteristics of the individual modes of transportation together with legal and administrative requirements that must be considered in the design of SEM items to assure efficient movement by existing and proposed transportation systems.

### **Transportability engineering**

The process of identifying and measuring limiting constraints, characteristics, and environments of transportation systems; the integration of these data into design criteria to use operational and planned transportation capability effectively; and the development of technical transportability guidance.

### **Transportability engineering analysis**

An evaluation of the transportability of an SEM item and its components, auxiliary, and ancillary equipment. An analysis will summarize its ability to be transported by the required modes of transportation.

### **Transportability problem item**

A TPI is materiel, regardless of its condition, in its shipping configuration which, because of its size, weight, fragile, or hazardous characteristics or lack of adequate means for lifting and tiedown will be denied movement, will require special permits or waivers and special equipment or handling, or will be unacceptably delayed when moving within existing or newly designed transportation systems. Materiel is considered a TPI when any of the following conditions apply:

- a. Item is wheeled or tracked, or is to be towed or self-propelled on or off highway.
- b. The item increases the physical characteristics of the designated transport medium.

- c. The item requires special handling or special loading procedures.
- d. Materiel exceeds any of the following conditions:
  - (1) Length—20 feet. (6.1 meters) (based on the external size of a standard 20-foot ISO container).
  - (2) Width—8 feet (2.4 meters) (based on the external size of a standard 20-foot ISO container).
  - (3) Height—8 feet (2.4 meters) (based on the external size of a standard 20-foot ISO container).
  - (4) Weight—10,000 pounds (4,535 kilograms) (based on the payload of the 5-ton truck).
  - (5) Weight per linear foot—1,600 pounds (726 kilograms).
  - (6) Floor contact pressure—50 pounds per square inch (344.75 kilo pascal).
  - (7) Maximum axle load (pneumatic tires)—5,000 pounds (2,268 kilograms).
  - (8) Maximum wheel load (pneumatic tires)—2,500 pounds (1,134 kilograms).
  - (9) Tire pressure—90 pounds per square inch (620.5 kilo pascal).

#### **Transportability report**

A report submitted by the MATDEV or contractor to SDDCTEA for all TPIs.

#### **Unit deployment analysis**

The final evaluation of the amount of strategic lift consumed by units receiving a TPI system.

#### **Unit deployment assessment**

Initial assessment of a unit's ability to be deployed in terms of strategic lift consumed. The assessment is based on the projected dimensions of the proposed systems with associated items of equipment.

### **Section III**

#### **Special Abbreviations and Terms**

##### **ATTLA**

Air Transportability Test Loading Activity

##### **IAT**

internal air transport

##### **ISO**

International Organization for Standardization

##### **LVAD**

low velocity airdrop

##### **SEM**

systems/equipment/munitions

**UNCLASSIFIED**

**PIN 004458-000**